

1. DESCRIPTION

1.1 General

Series pass Pulse Width Modulation (PWM) charge voltage control combined with a multistage charge control algorithm leads to superior charging and enhanced battery performance. The filtered PWM power control system uses highly efficient and reliable power MOSFET transistors.

Fully automatic temperature compensation of charge voltage is available to further improve charge control and battery performance. The local battery temperature sensor is built for long term reliability.

1.2 Features

- ❖ State of charge(SOC)
- ❖ PWM Control, microcontroller digital accuracy
- ❖ Three stage battery charging [boost– equalisation – float]
- ❖ Electronic protection
- ❖ Double digital LED number display for timer selection
- ❖ Local internal temperature sensor, and temperature compensation
- ❖ Protected against over current, and short circuit.
- ❖ Protected against reverse polarity connection of the solar panels and/or battery.
- ❖ With low voltage load disconnect and reconnect.
- ❖ Big terminals, big distance between terminals

2. INSTALATION

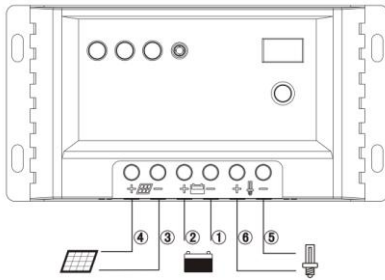

- Connect wires in order indicated 1-6
- Use with 12V or 24V batteries
- Use with 12V or 24V systems
- Do not exceed Solar and Load ratings Max output current 10A

3. LED INDICATORS



1. SUN indicator:
Green blink when solar is charging battery.
Green on when there is no charging
2. BAT indicator:
Green ON when battery level in the right range.
Green slowly flashing when battery level full.
Yellow ON when battery level low.
Red ON when load cut off.
Red blink in case of over temperature.
Green blink in case of over voltage.
3. LOAD indicator:
Red on when the output is working
Red slowly flashing when its over load
Red blink when the load is short-circuit.
(the load Amp is 1.25 times of rated current for 60 seconds, or the load Amp is 1.5 times of rated current for 5 seconds)

Please note:

1. The load output will cut off in case of over load or short circuit. After the first overload or short circuit the controller will resume to work automatically after 30 seconds. Please check the load and press the start push button to start when it happens again.
2. After over discharge, the load will reconnect when the battery is charged to 12.6V. (for 24V, use 2x)
3. After over discharge, the load can be reconnected automatically when the battery is charged exceeds the 12.6V.

4. TIMER SETTING CONTROL

Press the power switch for 3 seconds, and select the desired TIMER option, leave it until it is still which confirmed you have selected the right one. While you select the number, (you can press the button on for quick selection.)

The controller requires 10 minutes of continuous transition values before it starts to work these contrains avoid false transitions due to lightning or dark storm clouds.

A brief description follows below:

Number 0	Dusk-to-Dawn, light is on all night
Number 1	Light is turned on after sundown for 1 hour
Number 2	Light is turned on after sundown for 2 hours
Number 3	Light is turned on after sundown for 3 hours
Number 4	Light is turned on after sundown for 4 hours
Number 5	Light is turned on after sundown for 5 hours (Default)
Number 6	Light is turned on after sundown for 6 hours
Number 7	Light is turned on after sundown for 7 hours
Number 8	Light is turned on after sundown for 8 hours
Number 9	Light is turned on after sundown for 9 hours
Number 10	Light is turned on after sundown for 10 hours
Number 11	Light is turned on after sundown for 11 hours
Number 12	Light is turned on after sundown for 12 hours
Number 13	Light is turned on after sundown for 13 hours
Number 14 (3/OFF/1)	Light is turned on for 3 hrs after sundown, turn off then, and turned on for 1 hr before sunrise.
Number 15 (4/OFF/2)	Light is turned on for 4 hrs after sundown, turn off then, and turned on for 2 hrs before sunrise.
Number 16 (6/OFF/2)	Light is turned on for 6 hrs after sundown, turn off then, and turned on for 2 hrs before sunrise.
Number 17 (7/OFF/2)	Light is turned on for 7 hrs after sundown, turn off then, and turned on for 2 hrs before sunrise.
Number 18 (5/OFF/3)	Light is turned on for 7 hrs after sundown, turn off then, and turned on for 2 hrs before sunrise.
Number 19	24 hrs ON, light is ON all the time when there is output.
Number 20	Lights remain turned off, ON/OFF mode
Number 21	Test mode, lights on after it detects no light, lights off after it detects light.

Number 22	Start voltage: 4V
Number 23	Start voltage: 5V (Default)
Number 24	Start voltage: 6V

Note: the number for start voltage will not show again once you set it well. But it will display while you press the key on for setting.

5. SPECIFICATIONS

SUN'S SunLight controller	Sunlight-10 12/24	
	12V	24V
Battery Voltage	12V	24V
Rated charge current	5A or 10A	
Automatic load disconnect	Yes (maximum load 5A or 10A)	
Recommended solar panel array	12V	24V
Maximum solar voltage	25V	55V
Self-consumption	6mA	
Default settings		
Equalization charge (1)	14.4V	28.8V
Float charge (1)	13.6V	27.2V
Load disconnect	11.1V	22.2V
Load reconnect	12,6V (auto)	25.2V (auto)
Battery temperature sensor	Yes (Internal sensor)	
Temperature compensation	-30mV/°C	-60mV/°C
Protection class	IP20	
Enclosure		
Terminal size	6mm ² / AWG10	
Weight	200gr	
Dimension (h x w x d)	71x138x33.5 mm	
Mounting	Vertical wall mount Indoor only	
Humidity (non condensing)	Max. 95%	
Operating temperature	-35°C to +55°C (full load)	
Cooling	Natural convection	
Standards		
Safety	EN60335-1	
EMC	EN61000-6-1, EN61000-6-3	

6. SPECIFICATIONS

1. Charging LED indicator is off when it is daytime
 - a. The green Charging LED should be on or blink if its day time.

- b. Check that the proper battery type has been selected.
 - c. Check that all wire connections in the system are correct and tight. Check the polarity(+ and -) of the connections
 - d. Measure the PV array open-circuit voltage and confirm it is within normal limits. If the voltage is low or zero, check the connections at the PV array itself. Disconnect the PV from the controller when working on the PV array.
 - e. Measure the PV voltage and the battery voltage at the controller terminals. If the voltage at the terminals is the same(within a few tenths of volts) the PV array is charging the battery. If the PV voltage is close to the open circuit voltage of the panels and the battery voltage is low, the controller is not charging the batteries and may be damaged.
2. Load LED indicator is blinking, or flashing or on red(load not operating properly)
 - a. Check that the load is turned on. Check that no system fuses are defective.
 - b. Check connections to the load, and other controller and battery connections. Make sure voltage drops in the system wires are not too high.
 - c. If the LED indicator is blinking and no output, check if the load is short-circuit. Disconnect the load, and press the switch button, but for the first time short-circuit, the controller will return to work after 30 seconds automatically.
 - d. If the LED indicator is flashing and no output, check if the load is over the rated power. Reduce the load, and press the switch button, the controller will return to work after 30 seconds.

7. INSPECTION AND MAINTENANCE

The following inspections and maintenance tasks are recommended at least once per year for best controller performance

1. Confirm that the correct battery type has been selected.
2. Confirm that the current levels of the solar array and load do not exceed the controller ratings.
3. Tighten all the terminals. Inspect for loose, broken, or burnt wire connections. Be certain no loose strands of wire are touching other terminals
4. Press the TEST button(number: 19 or 20) to verify the lights are working
5. Check that the controller is securely mounted in a clean environment. Inspect for dirt, insects and corrosion.
6. Check the air flow around the controller is not blocked.
7. Protect from sun and rain. Confirm that water is not collecting under the cover
8. Check that the controller functions and LED indicators are correct for the

system conditions at that time.

9. Make sure the PV array is clean and clear of debris and snow. Confirm the array is oriented correctly for the installation location.

6. MECHANICAL DRAWING

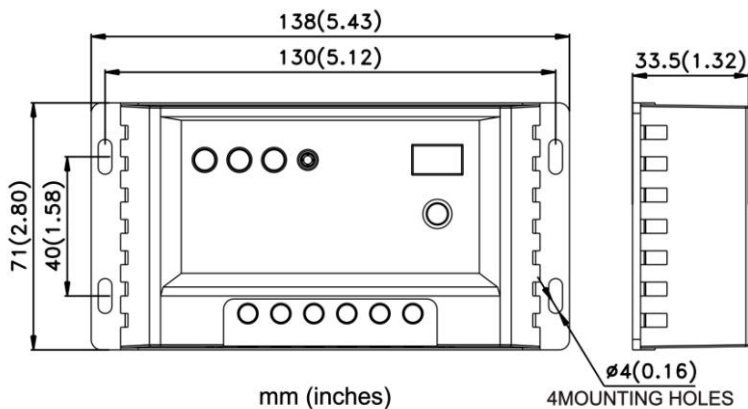

 SUN'S ENERGY CO., LIMITED.

Email: info@suns-power.com
ulandsolar@yeah.net

Website: www.suns-power.com