

Model (SL30TU-18MD) Specifications

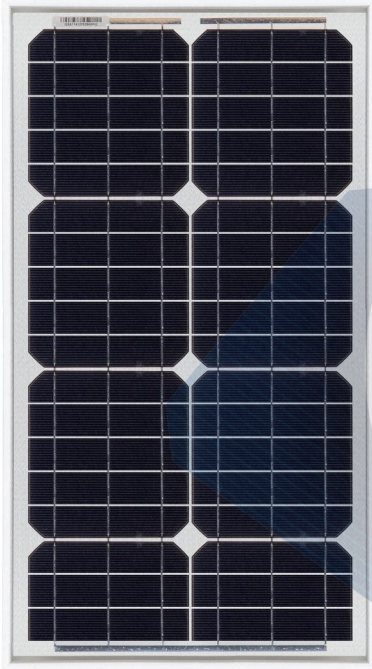

Electrical Data

Maximum Power(W)	30W
Optimum Power Voltage(Vmp)	18.57V
Optimum Operating Current(Imp)	1.62A
Open Circuit Voltage(Voc)	22.64V
Short Circuit Current(Isc)	1.73A
Cell Efficiency	17.96%
Module Efficiency	12.65%
Tolerance Wattage	0 +3%
NOCT	45°C +/-2°C

Benefits

- ❑ High efficiency solar cells with high transmission and textured glass are delivering high efficiency for modules;
- ❑ Tempered glass, EVA resin, and weatherproof film, plus aluminum frame for extended outdoor use;
- ❑ Modules independently tested to ensure conformance with certification and regulatory standards;
- ❑ Manufacturing facility certified to ISO 9001 quality management system standards.

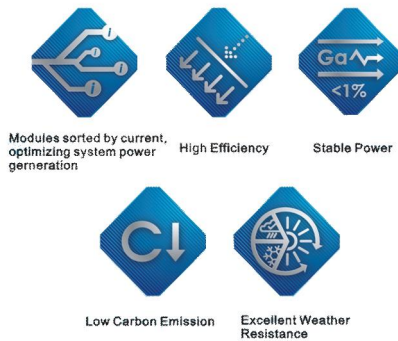

Modules sorted by current, optimizing system power generation

High Efficiency

Stable Power $G_a < 1\%$

Low Carbon Emission

Excellent Weather Resistance

Applications

- ❑ On-grid residential roof-tops
- ❑ On-grid commercial/industrial roof-tops
- ❑ Solar power stations
- ❑ Other on-grid applications

Temperature Coefficients

Temperature Coefficients of Isc(%)	+0.04
Temperature Coefficients of Voc(%)	-0.38
Temperature Coefficients of Pm(%)	-0.47
Temperature Coefficients of Im(%)	+0.04
Temperature Coefficients of Vm(%)	-0.38





IGNITE THE POWER OF NATURE

Monocrystalline Module
--small size 30Watt

Components & Mechanical

Solar Cell	156*30.6(32.1)	Mono
Number of Cell(pcs)	2*18	
Size of Module(mm)	650*360*28	
Front Glass Thikness(mm)	3.2	
Surface Maximum Load Capacity	2400-5400Pa	
Allowable Hail Load	23m/s ,7.53g	
Weight Per Piece(KG)	2.9	
Frame(Material Corners,etc.)	28#	
Temperature Range	-40°C to +85°C	
FF (%)	70-78%	
Standard Test Conditions	AM1.5 1000W/m ² 25°C	

Packing

Packing	Wooden Box
Pieces per container	105pcs/Pallets

Project Picture



Engineering Drawings

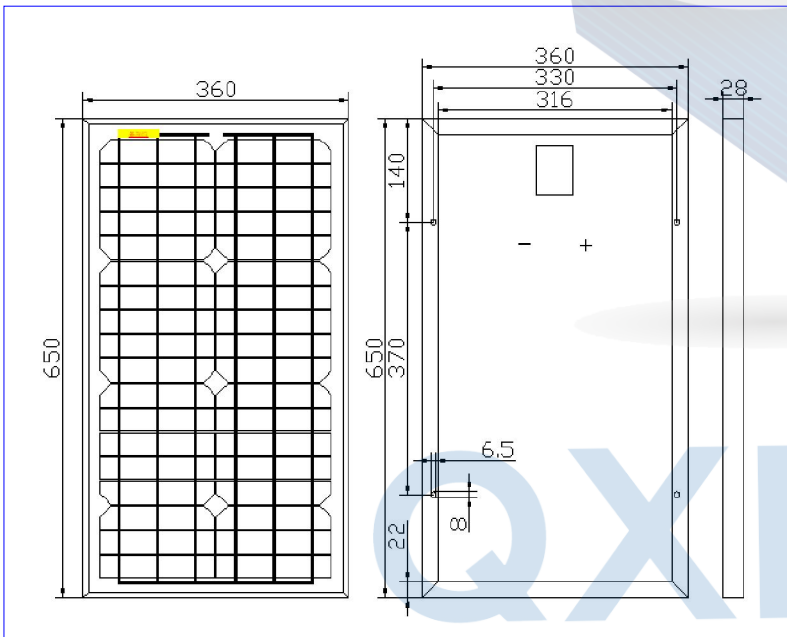

©2016 Ningbo Qixin Solar Electrical Appliance Co., Ltd. All rights reserved.
Specifications included in this datasheet are subject to change without notice.

Ningbo Qixin Solar Electrical Appliance Co., Ltd
ADD: No. 37 Jingang Road, Binhai Industrial Park,
Xiangshan County, Ningbo, 315700, China
WEB: <http://www.nbqxsolar.com>
TEL: 0086-(0)574-25758823
FAX: 0086-(0)574-25758824
E-mail: sales@nbqxsolar.com

