

JST MODULE JST50P(36) 50W

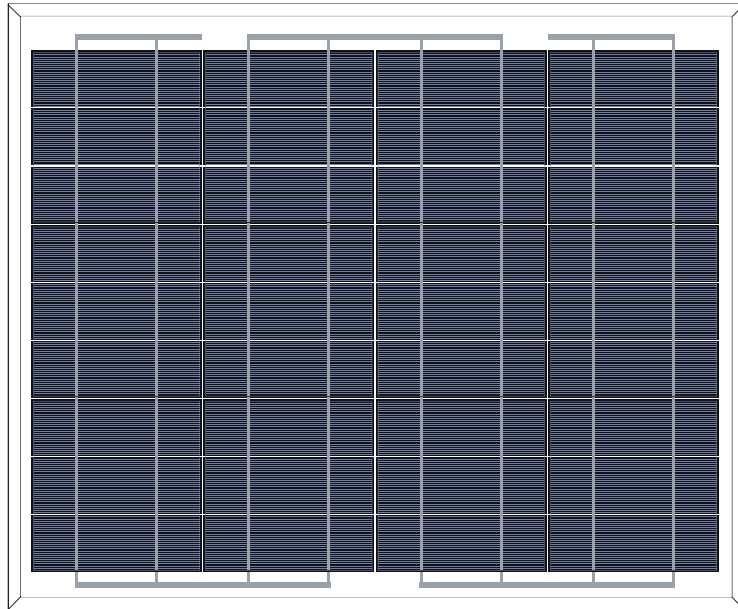

High conversion efficiency
High module efficiency to guarantee power output.



0 to +5W positive tolerance
Detailed information in Electrical Specifications.



Self-cleaning glass
Coating glass for self-cleaning, reduce surface dust.



48-hour response service



Outstanding low irradiation performance
Excellent module efficiency even in the weak light conditions, such as morning or cloudy.

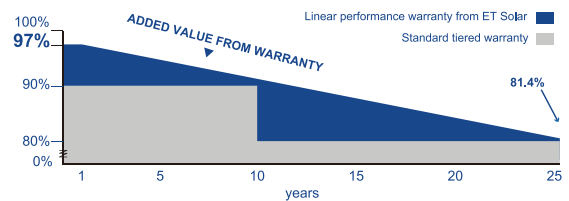

Excellent loading capability
2400Pa wind loads, 5400Pa snow loads.



25-year performance warranty

10-year warranty on materials and workmanship

IEC 61215 Ed.2
IEC 61730
UL 1703



JST Solar

ELECTRICAL DATA

Model Type	JST50P(36)
Peak Power (Pmax)	50W
Module Efficiency	13.8%
Maximum Power Voltage (Vmp)	18.3V
Maximum Power Current (Imp)	2.73A
Open Circuit Voltage (Voc)	22.2V
Short Circuit Current (Isc)	2.95A
Power Tolerance	±3%
Maximum System Voltage	1000V
Nominal Operating Cell Temperature	44.4±2°C
Maximum Series Fuse Rating	15A

MECHANICAL DATA

Cell Type	156×156mm
Number of Cells	36 (9×4)
Weight	5kg
Dimension	540×670×30mm
Max Load	5400 Pascals
Junction Box	IP67 rated MC4
Connector	Compatible PV
Wire Type	Wire

TEMPERATURE CHARACTERISTICS

Temp. Coeff. of Isc (TK Isc)	0.04% /°C
Temp. Coeff. of Voc (TK Voc)	-0.34% /°C
Temp. Coeff. of Pmax (TK Pmax)	-0.44% /°C

PACKING MANNER

Container	20' GP	40' GP
Pieces per Package	5	5
Pieces per Container	1500	3000

PHYSICAL CHARACTERISTICS

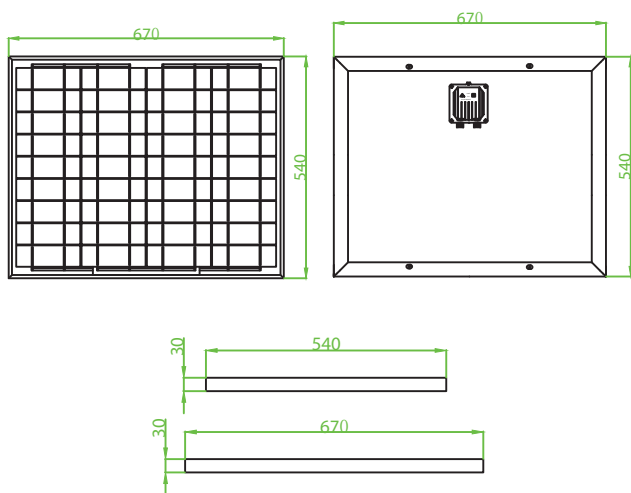

ELECTRICAL CHARACTERISTICS

Current-Voltage & Power-Voltage Curve (AM1.5, Cell Temperature 25°C)

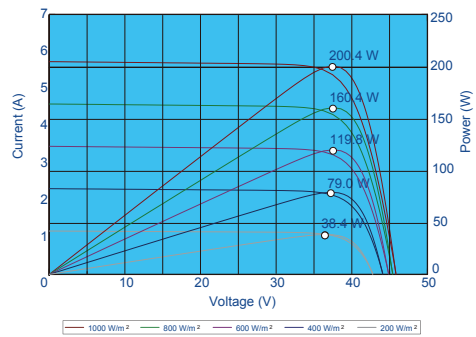

Temperature Dependence of Isc, Voc and Pmax

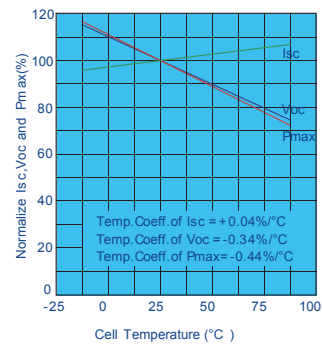

Irradiance Dependence of Isc, Voc and Pmax (Cell Temperature: 25°C)

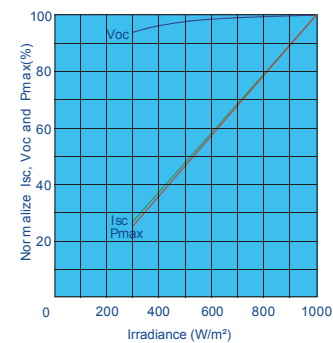

Note: the specifications are obtained under the Standard Test Conditions (STCs): 1000W/m² solar irradiance, 1.5 Air Mass, and cell temperature of 25°C. The NOCT is obtained under the Test Conditions: 800W/m², 20°C ambient temperature, 1m/s wind speed, AM 1.5 spectrum.

Please contact support@jusolar.com for technical support. The actual transactions will be subject to the contracts. This parameters is for reference only and it is not a part of the contracts. The specifications are subject to change without prior notice.