

**POLYCRYSTALLINE
SILICON MODULE**

 **ECSOLAR**

P6-05

POLYCRYSTALLINE SILICON MODULE

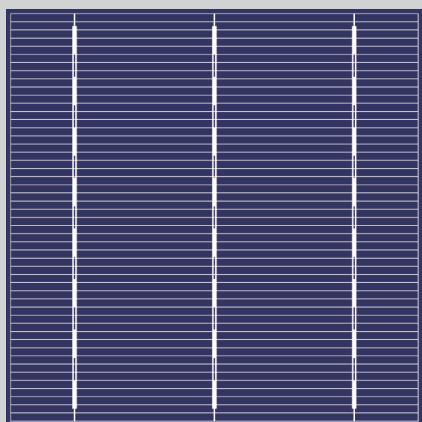
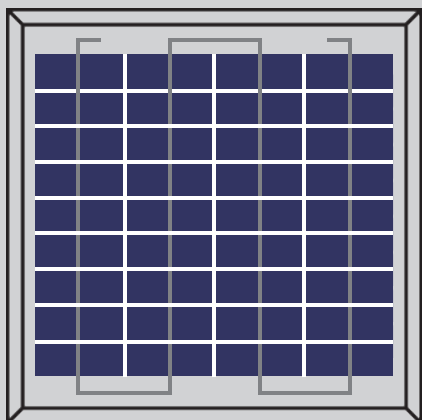

Products Characteristics



Widely using of the most popular and mature type of modules for off-grid system.



Leading manufacturing technology in PV industry, strictly controlling the quality of raw materials and the process of producing



100% EL inspection, ensures modules are defects free.



Cells binned by current to improve module performance



Anti reflective glass. Not only to increase the light absorption, but also to make the module has the function of self-cleaning in water environment, effectively reducing the power loss caused by dust.



Outstanding performance in low-light irradiance environments.



Excellent mechanical load resistance: Certified to withstand high wind loads(2400pa) and snow loads(2400pa).



High salt and ammonia resistance



Positive power tolerance: 0~+5w

5 years
products
warranty

25 year
power output
warranty

Add: Industrial Park C, Guanlin Town, Yixing
214251, China
Tel:+86-25 8659 2702
Fax:+86-25 8659 2703
Email:sales@ecsolar.com
Web:www.ecsolar.com

Warranty

- 5 years product warranty
- 10-years 90% of Min. rated output power, and 25-years 80% of Min. rated output power warranty

Comprehensive Certificates

- ISO 9001:2008: Quality management systems
- IEC61215、IEC61730
- CQC Certificate
- CE Certificate
- SGS-TUV Certificate



Specifications subject to technology and test conditions, ECSOLAR reserves the right of final interpretation

▼ Engineering Drawings (Front Side)

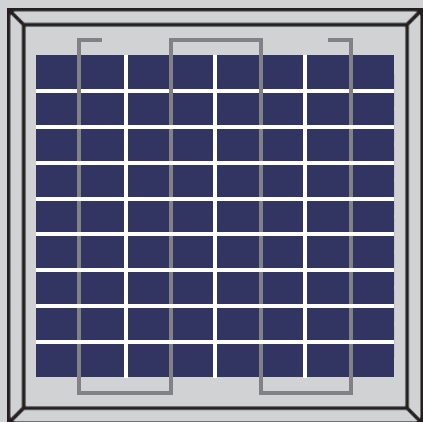

▼ Engineering Drawings (Back Side)

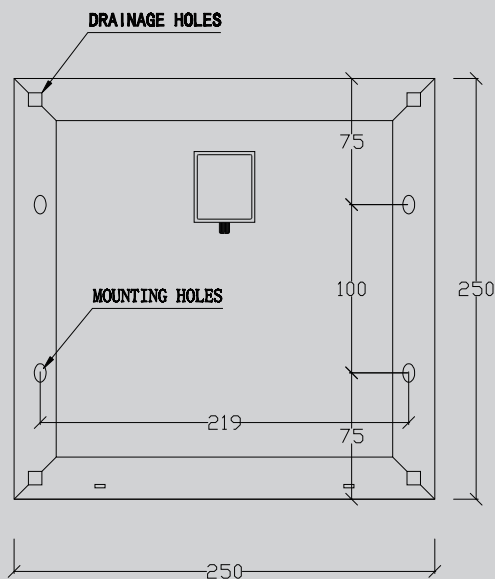

Add: Industrial Park C, Guanlin Town, Yixing
214251, China
Tel:+86-25 8659 2702
Fax:+86-25 8659 2703
Email:sales@ecsolar.com
Web:www.ecsolar.com

Raw materials and Mechanical Parameters

P6-05	
Type of Cells(mm)	poly52 × 19.5
NO. of Cells and Connections	4 × 9=36
Dimensions(mm)(L*W*H)	250 × 250 × 25
Weight(kg)	0.8
Glass	3.2mm Tempered Glass
Encapsulation	EVA
Backsheet	Multilayer Composite
Aluminium-Frame	Silvery/Black Anodized aluminium alloy
Junction-Box	IP65
Cable	NA, but customized is acceptable
Connector	NA, but MC4 and MC4 Compatible are acceptable
Package Configuration	30pcs/ctn

Performance Parameters

P6-05	
Maximum System Voltage	700V
Operating Temperature	-45~+80°C
Maximum Series Fuse	/
Maximum Static Load,Front Side (e.x. Snow,Wind)	2400PA
Maximum Static Load, Back Side(e.x. Wind)	2400PA
Application Grade	Class A

Electrical Parameters (Standard Test Condition)

P6-05	
Rated Maximum Power(Mp)	5W
Power Tolerance	0- +5W
Cell Efficiency	14.0%
Open Circuit Voltage(Voc)	22.2V
Maximum Power Voltage(Vmp)	17.3V
Short Circuit Current(Isc)	0.31A
Maximum Power Current(Imp)	0.29A
Temperature Coefficient of Isc	+0.06%
Temperature Coefficient of Voc	-0.33%
Temperature Coefficient of Pmp	-0.45%
Standard Test Condition	Irradiance:1000W/M2,Cell Temperature:25°C,Spectrum AM:1.5

The Electrical Parameters of the module are the average theory figure under the standard test condition, each one exists difference. Can not be treated as the basis of module delivery.