



## SOLAR PHOTOVOLTAIC MODULES

### Aditi's Photovoltaic Modules

- ★ High efficiency, Mono or Multi crystalline solar cells with high transmission and textured glass delivering a module series efficiency of up to 14.3%, minimizing installation costs and maximizing the kWh output of your system per unit area.
- ★ High quality, low iron, high transmissivity, tempered and toughened glass to ensure high light absorption.
- ★ Tin Copper interconnect increases Solderability and Conductivity. This also results in maximum output efficiency from the Module.
- ★ Premium quality encapsulation material ensuring high quality lamination leading to better performance.
- ★ Polyster tedlar used as a back sheet prevents from moisture and mechanical damage.
- ★ Weather resistant frame - seal helps preventing water seepage and protects the system from humidity.
- ★ Anodized Aluminum frame gives the system strong, corrosion-free structural support.
- ★ Produced in an ISO 9001:2008 & 14001:2004 certified production facilities.
- ★ Certifications: IEC 61215, IEC 61730-1&2, IEC 61701.
- ★ Warranty,
  - a) 90% of the rated power is guaranteed for a period of 10 years.
  - b) 80% of the rated power is guaranteed for a period of 25 years.



#### Model No: ADT 12200

#### Electrical Specifications:

Product Description	<b>12V - 200WP</b>
Rated POWER <b>P<sub>max</sub> - [W]</b>	<b>200.00</b>
Rated Voltage <b>V<sub>max</sub> - [V]</b>	<b>17.50</b>
Rated Current <b>I<sub>max</sub> - [A]</b>	<b>11.43</b>
Open Circuit Voltage <b>V<sub>oc</sub> - [V]</b>	<b>21.50</b>
Short Circuit Current <b>I<sub>sc</sub> - [A]</b>	<b>12.23</b>
Module Efficiency <b>η - [%]</b>	<b>14.40</b>
Tolerance	<b>± 3%</b>

Standard Test Conditions: Irradiance 1000 W/ m<sup>2</sup> , Module temperature 25°C, Spectrum AM 1.5

#### Module IV-Curve:

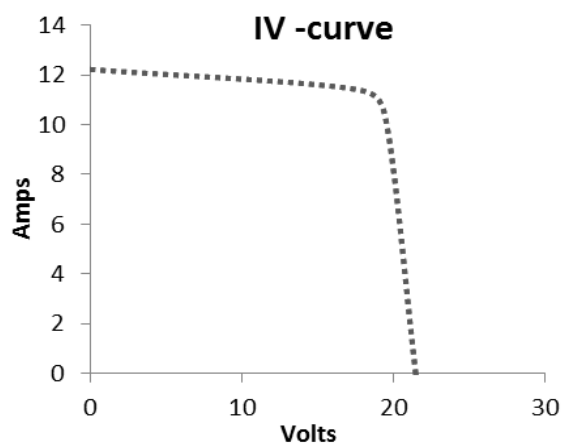

#### Temperature Coefficients

<b>Voltage V<sub>oc</sub></b>	: <b>-0.33%/K</b>
<b>Current I<sub>sc</sub></b>	: <b>+0.06%/K</b>
<b>Power P<sub>max</sub></b>	: <b>-0.40%/K</b>

<b>Maximum system voltage</b>	: <b>1000 V DC</b>
<b>Operating Module Temperature</b>	: <b>-40°C to +85°C</b>
<b>NOCT</b>	: <b>47°C ± 2°C</b>

#### Certifications



### Module Drawing & Mounting details:

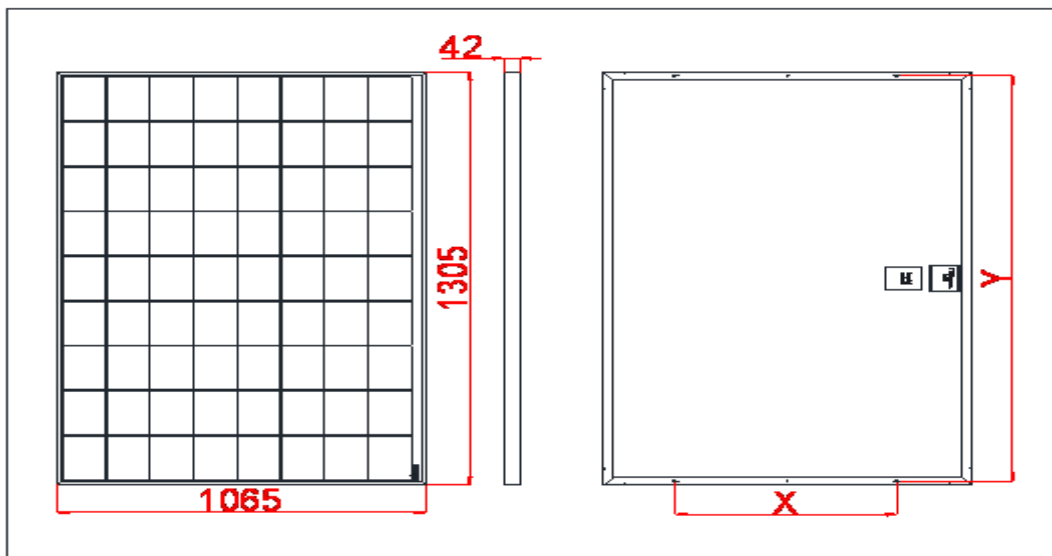

### Mechanical Specifications:

Length [mm]	1305 ± 2
Width [mm]	1065 ± 2
Thickness [mm]	42
X [mm]	640 ± 2
Y [mm]	1265 ± 2
Mounting hole	10X7 mm slot
Earth hole	5mm dia
Drain hole	5mm dia
Aprox. weight [Kg]	17.25
No. of cells	72

### Other Characteristics:

Cell type	Mono / Multi Crystalline
Front Glass	Toughened Textured Glass
Glass thickness	3.2 mm
Cell Encapsulation	EVA (Ethylene Vinyl Acetate)
Back sheet	Poly vinyl Fluoride
Frame	Anodized, Extruded Aluminum frame
Junction Box	Nylon / ABS moulded 4 rail junction box with bypass diodes & cables

Due to continuous upgradation of products, specifications mentioned are subject to change without prior notice.



Plot No: 17, ALEAP Indust. Estate, Gajula Ramaram, Qutbullapur (M), R.R.Dist., HYDERABAD  
500090, ANDHRA PRADESH – INDIA TEL:+91-40-2004 0285 MOB: +91-8978854777 / 555

WEBSITE: [www.aditisolar.in](http://www.aditisolar.in), EMAIL: [marketing@aditisolar.in](mailto:marketing@aditisolar.in), [spvprojects@aditisolar.in](mailto:spvprojects@aditisolar.in)