

EWVO

WORLD CLASS SOLAR MODULES

60 Cells
Polycrystalline
Module

270-300W
Power Output Range

16.5-18.4%
Maximum Efficiency

0~+5w
Power Tolerance



ROBOTIC PLANT

PRODUCT WARRANTY
12
Years
PRODUCT WARRANTY

PERFORMANCE WARRANTY
30
Years
PERFORMANCE WARRANTY



WORLD CLASS PRODUCTS

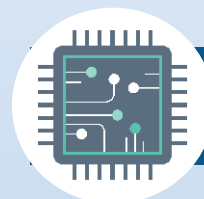

FULLY AUTOMATED ADVANCED SOLAR PLANT

100%

100% A GRADE CELLS ONLY



EVERY MODULE DOUBLE TESTED & CHECKED



PRODUCTION BASE IN VIETNAM



NO COMPROMISE ON QUALITY



CE



PRODUCT SPECIFICATIONS

● Our most versatile product

- Compatible with all major BOS components and system designs
- 60-cell module power output up to 300W
- Up to 165 W/m² power density Highly reliable due to stringent quality control
- 1500V UL/1500V IEC certified

● HIGHLY RELIABLE DUE TO STRINGENT QUALITY CONTROL

- Over 30 in-house tests (UV, TC, HF, and many more)
- In-house testing goes well beyond certification requirements
- PID resistant
- 100% EL double inspection

● CERTIFIED TO WITH STAND CHALLENGING ENVIRONMENTAL CONDITIONS

- 2400 Pa wind load
- 5400 Pa Snow load
- 35 mm hail stones at 97 km/h

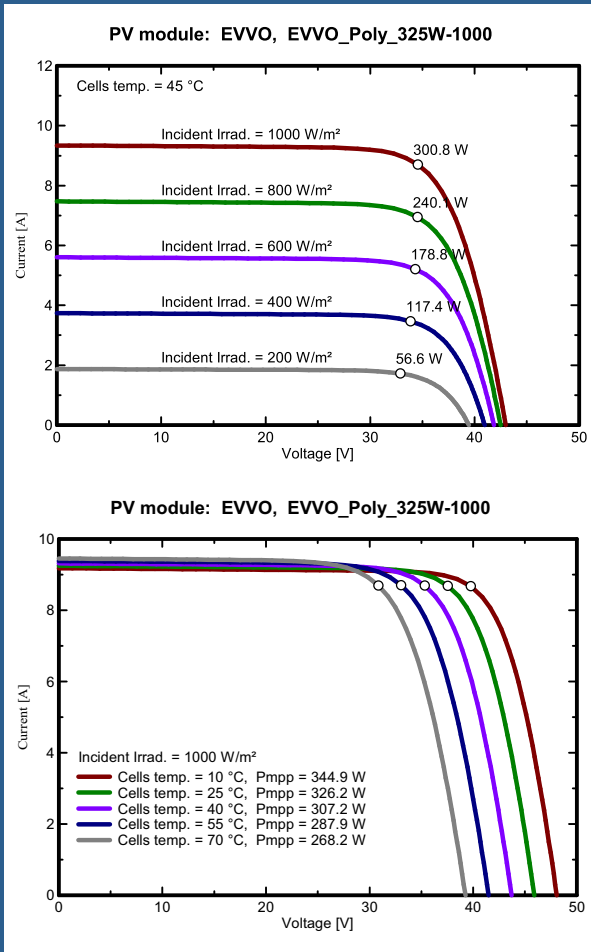

LINEAR PERFORMANCE WARRANTY

12 Year Product Warranty
30 year Linear Power Warranty

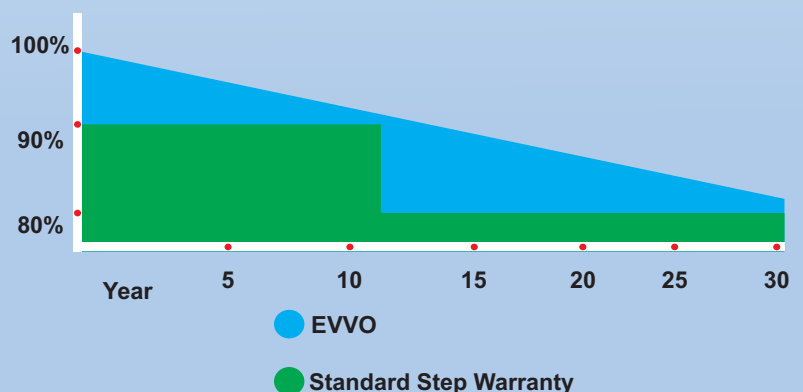

Electrical Specifications (standard test conditions)

Maximum Power -P _{MAX} (Wp)	270	275	280	285	290	295	300
Power Tolerance -P _{MAX} (W)	0 ~ +5%						
Maximum power point of operating voltage -P _{MPP} (V)	30.9	31.1	31.4	31.7	32.0	32.3	32.6
Maximum power point of operating current) -I _{MPP} (A)	8.73	8.84	8.92	9.02	9.12	9.22	9.32
Open circuit voltage -V _{oc} (V)*	38.4	38.5	38.7	38.9	39.1	39.3	39.5
Short circuit current - IM (A)	9.18	9.25	9.34	9.41	9.48	9.52	9.57
Module Efficiency (%)	16.5	16.8	17.2	17.5	17.8	18.1	18.4

Standard test conditions under Measured Value:(air quality AM1.5, Irradiance 1000W / m², cell temperature 25 °C)

Electrical Index (under nominal operating cell temperature conditions)

Maximum Power -P _{MAX} (Wp)	200	204	207	210	213	216	219
Maximum power point of operating voltage -P _{MPP} (V)	28.7	29.0	29.2	29.4	29.6	29.8	30.0
Maximum power point of operating current) -I _{MPP} (A)	6.97	7.03	7.10	7.17	7.24	7.31	38.0
Open circuit voltage -V _{oc} (V)*	35.5	35.6	35.8	36.0	36.2	36.4	36.8
Short circuit current - IM (A)	7.41	7.47	7.55	7.61	7.67	7.73	7.79

NOCT: Irradiance 800W / m², ambient temperature of 20 °C, wind speed 1m / s

Temperature Rating

Limit parameter

Nominal Operating Cell Temperature (NOCT)	44°C (±2°C)	Working Temperature	-40~+85°C
Maximum power (P _{MAX}) Temperature Coefficient	- 0.41%/°C	Maximum system voltage	1500V DC (IEC)
Open-circuit voltage (VOC) Temperature Coefficient	- 0.32%/°C		1500V DC
Short circuit current (ISC) Temperature Coefficient	0.05%/°C	Maximum fuse rated Current	15A

Mechanical Specifications

Solar cell Type	156.75mm × 156.75mm Poly -crystalline
Number of Cells	1 module 60pieces (6 × 10)
Dimensions	1640 × 992 × 35 mm
Weight	18.6 kg
Glass	3.2mm, High transparency, anti-reflective coatings toughened glass
Backsheet	white /black
Frame	Silver, anodized aluminum
Junction Box	Protection level IP 68
Cable	4.0 mm ² , 1000 mm Photovoltaic dedicated cables
Connector	MC4 compatible

P60 Module Packing

Name	Dimensions (mm)	Weight (kg)
Pallet	1680*1130*123mm	29
Carton Box(30pcs)	1670*1120*1000mm	10
Carton Box (2pcs)	1670*1000*80mm	2

Maximum stacking height of P60 Module Packing : 30 pcs per box allow stacking of the same 30 pcs box , Plus 2 boxes per box 2pcs ;

30 pcs single pallet dimension height : 1123mm Weight : 598KG

Height of 2 pallet stacking 2 pallet per box 2pcs : 2406mm Weight : 1243.4KG

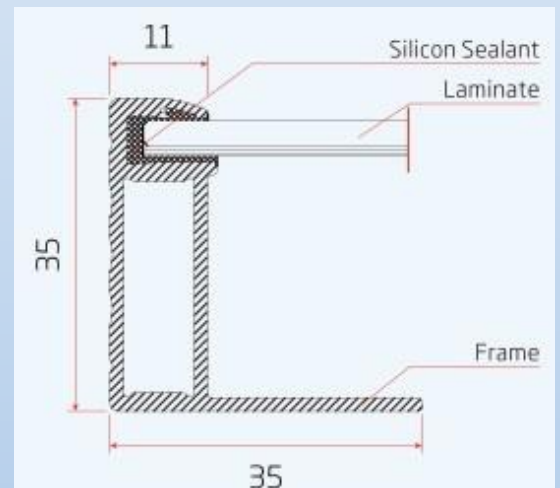
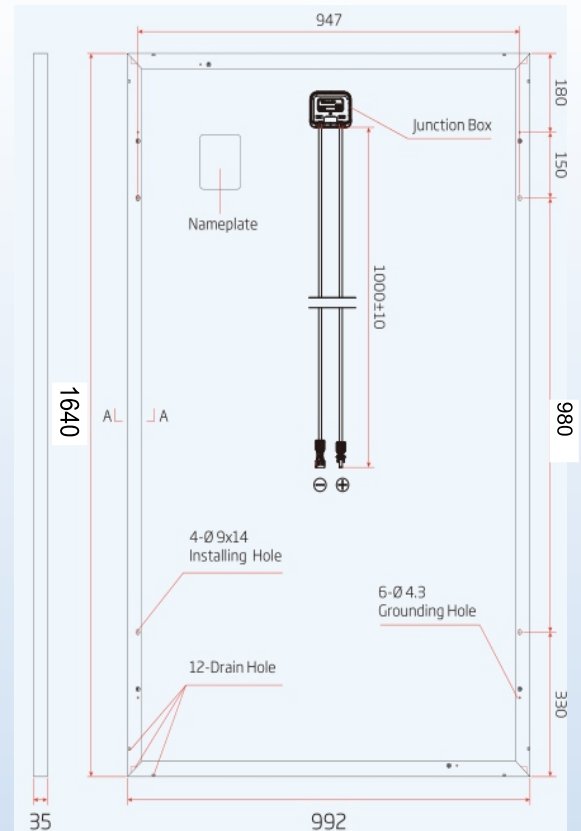

Packaging Method

Modules per box: 30 pcs

Modules per 40 ft container: 840 pcs

* Installation depends on the mechanical load

Authorized Dealer

Registered Office :

Commercial Centre,
27 Hillier Street, Sheung Wan,
Hong Kong,Asia.

Contact : +91 7338821798
E-Mail : info@evvosolar.com
Skype : evvosolar

Manufacturing Unit :

Tien Son Industrial Zone,
Hoan Son Commune,
Tien Du District, Bac Ninh

E-Mail :
vietnam@evvosolar.com

Global Sales Office :

Sidco Industrial Estate,
Ambattur, Chennai - 600053
India.

Contact : +91 7338821798
E-Mail : sales@evvosolar.com
Skype : evvosolar

