

## MONOCRYSTALLINE SILICON MODULE

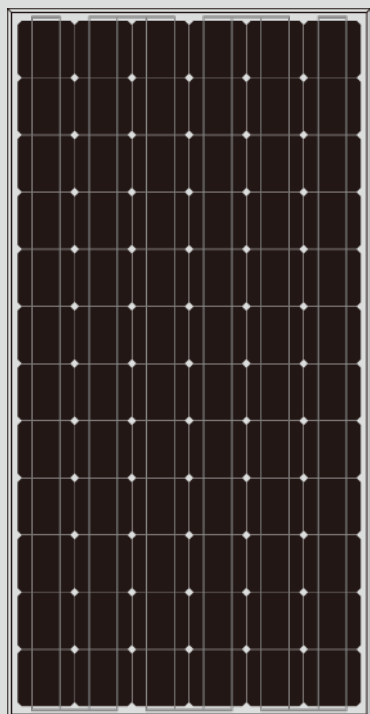

0260



**10** years  
products  
warranty

**25** year  
power output  
warranty

Add: CuiBei Industrial Park, Henglin Town, Wujin District, Changzhou City, Jiangsu Province, China.

Tel: +86-519-85260699

Fax: +86-519-85260299

Email: info@gsunp.com

Web Site: www.gsunp.com

# GSUNpower

WWW.GSUNP.COM

## M5-190 M5-195 M5-200 M5-205 M5-210 MONOCRYSTALLINE SILICON MODULE

### Products Characteristics



Widely using of the most popular and mature type of modules for off-grid system.



Leading manufacturing technology in PV industry, strictly controlling the quality of raw materials and the process of producing



100% EL inspection, ensures modules are defects free.



Cells binned by current to improve module performance



Anti reflective glass. Not only to increase the light absorption, but also to make the module has the function of self-cleaning in water environment, effectively reducing the power loss caused by dust.



Outstanding performance in low-light irradiance environments.



Excellent mechanical load resistance: Certified to withstand high wind loads(2400pa) and snow loads(5400pa).



High salt and ammonia resistance



Positive power tolerance: 0~+5w

### Warranty

- 10 years product warranty
- 10-years 90% of Min. rated output power, and 25-years 80% of Min. rated output power warranty

### Comprehensive Certificates

- ISO Certificate
- SGS-TUV Certificate
- CQC Certificate
- IEC61215、IEC61730 Certificate
- CE Certificate

Specifications subject to technology and test conditions,  
GSUN Power reserves the right of final interpretation

# M5-190 M5-195 M5-200 M5-205 M5-210

Engineering Drawings (Front Side)

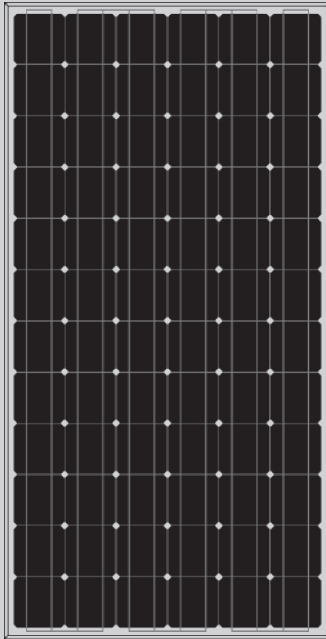

Engineering Drawings (Back Side)

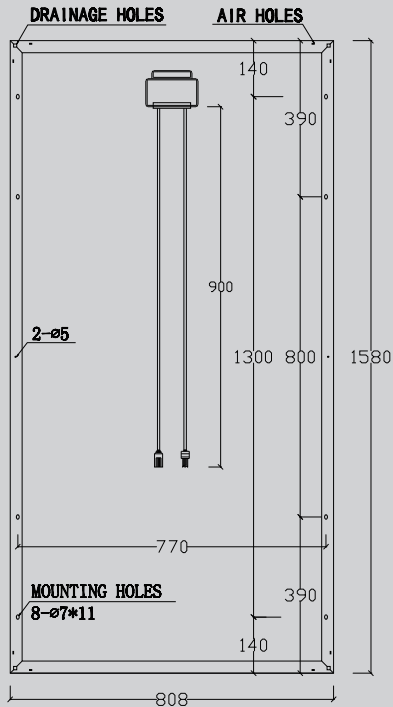

Add: CuiBei Industrial Park, Henglin Town, Wujin District, Changzhou City, Jiangsu Province, China.

Tel: +86-519-85260699

Fax: +86-519-85260299

Email: info@gsunp.com

Web Side: www.gsunp.com

## Raw materials and Mechanical Parameters

	M5-190	M5-195	M5-200	M5-205	M5-210
Type of Cells(mm)	mono125x125				
NO. of Cells and Connections	6x12=72				
Dimensions(mm)(L*W*H)	1580x808x35				
Weight(kg)	15.8				
Glass	3.2mm Tempered Glass				
Encapsulation	EVA				
Backsheet	Multilayer Composite				
Aluminium-Frame	Silvery/Black Anodized aluminium alloy				
Junction-Box	IP65/IP67				
Cable	4mm <sup>2</sup> , 900mm				
Connector	MC4 OR MC4 Compatible				
Package Configuration	Surrounding ctn+26pcs/ctn				

## Performance Parameters

	M5-190	M5-195	M5-200	M5-205	M5-210
Maximum System Voltage	1000V				
Operating Temperature	-45~+80°C				
Maximum Series Fuse	10A				
Maximum Static Load, Front Side (e.x. Snow, Wind)	5400Pa				
Maximum Static Load, Back Side (e.x. Wind)	2400Pa				
Application Grade	Class A				

## Electrical Parameters (Standard Test Condition)

	M5-190	M5-195	M5-200	M5-205	M5-210
Rated Maximum Power(Mp)	190W	195W	200W	205W	210W
Power Tolerance	0-5Wp				
Cell Efficiency	17.1%	17.5%	17.9%	18.4%	18.9%
Open Circuit Voltage(Voc)	45.2V	45.4V	45.6V	45.8V	45.9V
Maximum Power Voltage(Vmp)	35.4V	35.6V	35.9V	36.2V	36.4V
Short Circuit Current(Isc)	5.51A	5.64A	5.76A	5.89A	5.99A
Maximum Power Current(Imp)	5.37A	5.48A	5.57A	5.67A	5.77A
Temperature Coefficient of Isc	+0.06%				
Temperature Coefficient of Voc	-0.33%				
Temperature Coefficient of Pmp	-0.45%				
Standard Test Condition	Irradiance:1000W/M2, Cell Temperature:25°C, Spectrum AM:1.5				

The Electrical Parameters of the module are the average theory figure under the standard test condition, each one exists difference. Can not be treated as the basis of module delivery.