

Phono[®] Solar

Smart Module

solaredge
architects of energy™

Mono/300-310W

- 
Up to 25% More Energy
 Increased energy yield & faster return on investment through module-level MPPT
- 
Cost Efficient Maintenance
 Full visibility of system performance & remote troubleshooting
- 
Constraint Free Design
 Maximum space utilization with minimum design time
- 
Safety Guaranty
 Safety during installation, maintenance, firefighting & other emergencies

Bloomberg **Tier1**
NEW ENERGY FINANCE



TOP PERFORMER

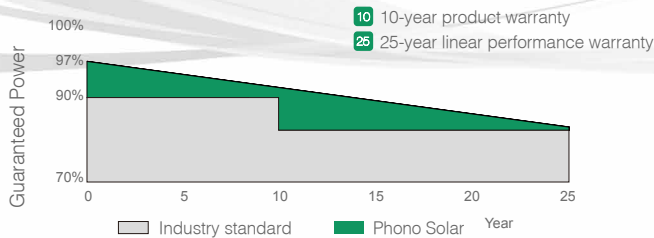

EN EN-20180815

SINOMACH | SUMEC
SUMEC GROUP CORPORATION

ELECTRICAL TYPICAL VALUES

Model	PS300M-20/U	PS305M-20/U	PS310M-20/U
Type	Monocrystalline 6 inch x 6 inch square, 6 × 10 pieces in series		
Rated Power (Pmpp)	300W	305W	310W
Tolerance	0~+5w		
Rated Current (Impp)	9.32	9.43	9.54
Rated Voltage (Vmpp)	32.19	32.35	32.50
Short Circuit Current (Isc)	9.82	9.87	9.92
Open Circuit Voltage (Voc)	39.90	40.00	40.10
Module Efficiency (%)	18.44	18.75	19.04
NOCT (Nominal Operation Cell Temperature)	45±2°C		
Voltage Temperature Coefficient	-0.35%/°C		
Current Temperature Coefficient	+0.07%/°C		
Power Temperature Coefficient	-0.45%/°C		

MECHANICAL CHARACTERISTICS

	Length: 1640mm (64.57 inch)
Dimension (L× W × H)	Width: 992mm (39.06 inch)
	Height: 35mm (1.38 inch)
Weight	18kg (39.68 lbs)
Front Glass	3.2mm toughened glass
Frame	Anodized aluminium alloy
Cable	4mm ² (IEC) , Length:900mm or Customized length
Junction Box	IP 68 rated

ABSOLUTE MAXIMUM RATING

Parameter	Values
Operating Temperature	From -40 to +85°C
Hail Diameter @ 80km/h	Up to 25mm
Surface Maximum Load Capacity	Up to 5400Pa
Maximum Series Fuse Rating	15A
IEC Application Class (IEC61730)	A
Fire Rating (IEC61730)	C
Module Fire Performance (UL 1703)	Type1
Maximum System Voltage	DC 1000V (IEC)

PV SYSTEM DESIGN USING A SOLAREEDGE INVERTER (FOR EU & APAC)

	1ph	3ph	3ph-MV
Minimum number of modules per string	300		
	305	8	16
	310		18
Maximum number of modules per string	300	17	37
	305	17	36
	310	16	36
Maximum power per string	5250	11250	12750
Parallel strings of different lengths or orientations	Yes		

- In compliance with our warranty terms and conditions.
- Measurement conditions under irradiance level of Standard Test Conditions(STC): 1000W/m²
Air mass 1.5 Spectrum, cell temperature of 25°C.

ELECTRICAL CHARACTERISTICS

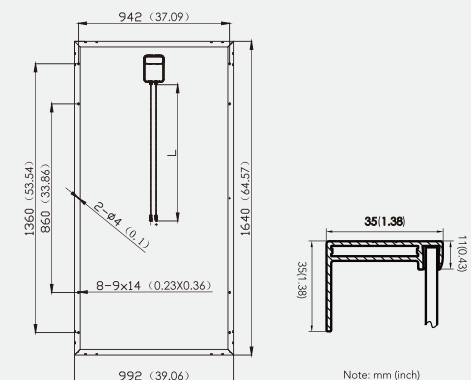
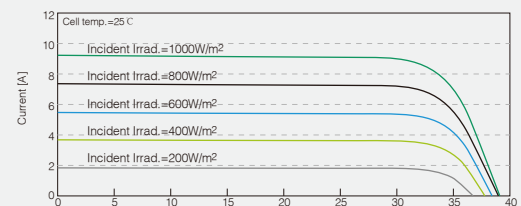
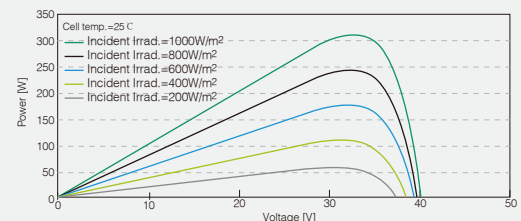

PACKING CONFIGURATION

Container	20' GP	40' HQ
Pieces/Container	312	896

OUTPUT DURING OPERATION MODULES CONNECTED TO SOLAREEDGE INVER

Maximum output current	15 Adc
Operating output voltage	5-60 Vdc
Output in Standby mode with SolarEdge inverter or with SMI and Non-SolarEdge inverter (when disconnected from inverter or inverter off)	1 Vdc