

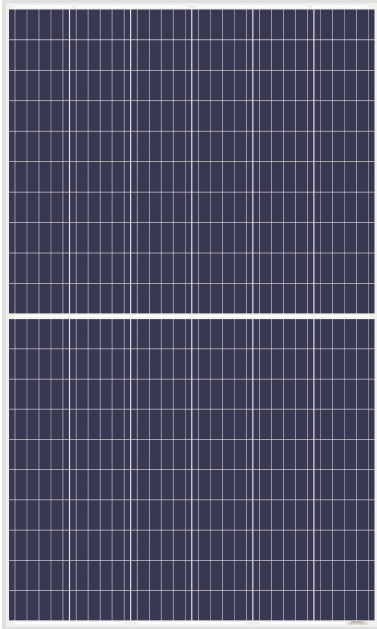

AS-6P30-HC

POLYCRYSTALLINE MODULE



ADVANCED PERFORMANCE & PROVEN ADVANTAGES

- High module conversion efficiency up to 18.05% by using innovative Half-cell design and five busbar cell technology.
- Low temperature coefficient and excellent performance under high temperature and low light conditions.
- Robust aluminum frame ensures the modules to withstand wind loads up to 2400Pa and snow loads up to 5400Pa.
- High reliability against extreme environmental conditions (passing salt mist, ammonia and hail tests).
- Potential induced degradation (PID) resistance.
- Positive power tolerance of 0 ~ +3 %.

CERTIFICATIONS

- IEC61215, IEC61730, IEC62716, IEC61701, CE, CQC, CGC, ETL(USA), JET(Japan), J-PEC(Japan), Kemco(South Korea), KS(South Korea), MCS(UK), CEC(Australia), FSEC(FL-USA), CSI Eligible(CA-USA), Israel Electric(Israel), InMetro(Brazil), TSE(Turkey)
- ISO9001:2008: Quality management system
- ISO14001:2004: Environmental management system
- OHSAS18001:2007: Occupational health and safety management system

SPECIAL WARRANTY

- 12 years limited product warranty.
- Limited linear power warranty: 12 years 91.2% of the nominal power output, 30 years 80.6% of the nominal power output.

Passionately
committed to
delivering innovative
energy solution

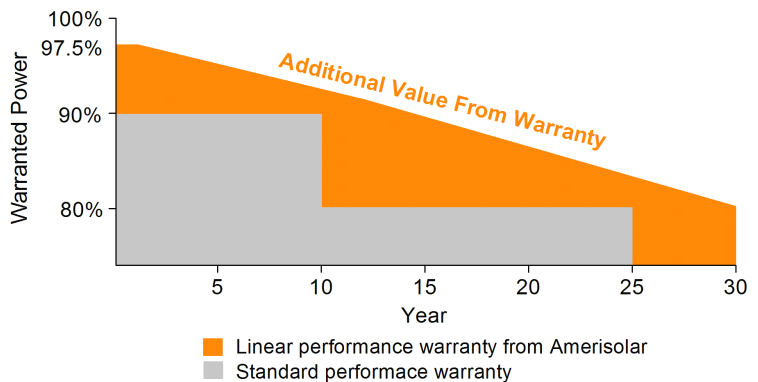

ELECTRICAL CHARACTERISTICS AT STC

Nominal Power (P_{max})	270W	275W	280W	285W	290W	295W	300W
Open Circuit Voltage (V_{oc})	38.2V	38.4V	38.6V	38.8V	39.0V	39.2V	39.4V
Short Circuit Current (I_{sc})	9.24A	9.33A	9.42A	9.51A	9.60A	9.69A	9.78A
Voltage at Nominal Power (V_{mp})	31.0V	31.2V	31.4V	31.6V	31.8V	32.0V	32.2V
Current at Nominal Power (I_{mp})	8.71A	8.82A	8.92A	9.02A	9.12A	9.22A	9.32A
Module Efficiency (%)	16.25	16.55	16.85	17.15	17.45	17.75	18.05
Operating Temperature	-40°C to +85°C						
Maximum System Voltage	1000V DC						
Fire Resistance Rating	Type 1(in accordance with UL1703)/Class C(IEC61730)						
Maximum Series Fuse Rating	20A						

STC: Irradiance 1000W/m², Cell temperature 25°C, AM1.5

ELECTRICAL CHARACTERISTICS AT NOCT

Nominal Power (P_{max})	200W	204W	207W	211W	215W	218W	222W
Open Circuit Voltage (V_{oc})	35.1V	35.3V	35.5V	35.7V	35.9V	36.1V	36.3V
Short Circuit Current (I_{sc})	7.48A	7.56A	7.63A	7.70A	7.78A	7.85A	7.92A
Voltage at Nominal Power (V_{mp})	28.2V	28.4V	28.6V	28.8V	29.0V	29.2V	29.4V
Current at Nominal Power (I_{mp})	7.10A	7.19A	7.24A	7.33A	7.42A	7.47A	7.56A

NOCT: Irradiance 800W/m², Ambient temperature 20°C, Wind Speed 1 m/s

MECHANICAL CHARACTERISTICS

Cell type	Polycrystalline 156.75x78.375mm (6x3inches)
Number of cells	120 (6x20)
Module dimensions	1675x992x35mm (65.94x39.06x1.38inches)
Weight	18.5kg (40.8lbs)
Front cover	3.2mm (0.13inches) tempered glass with AR coating
Frame	Anodized aluminum alloy
Junction box	IP68, 3 diodes
Cable	4mm ² (0.006inches ²)
Connector	MC4 or MC4 compatible

TEMPERATURE CHARACTERISTICS

Nominal Operating Cell Temperature (NOCT)	43°C±2°C
Temperature Coefficients of P_{max}	-0.37%/°C
Temperature Coefficients of V_{oc}	-0.30%/°C
Temperature Coefficients of I_{sc}	0.052%/°C

PACKAGING

Standard packaging	30pcs/pallet
Module quantity per 20' container	360pcs
Module quantity per 40' container	780pcs(GP)/858pcs(HQ)

ENGINEERING DRAWINGS

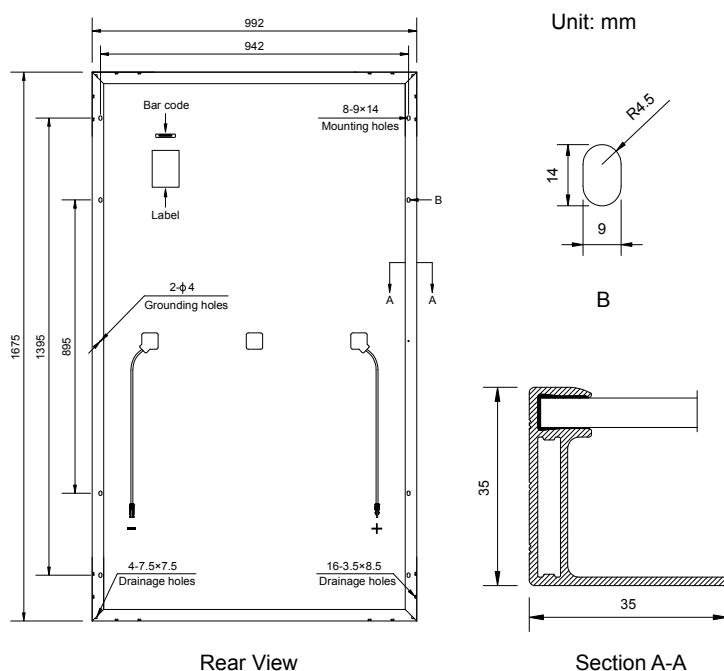

IV CURVES

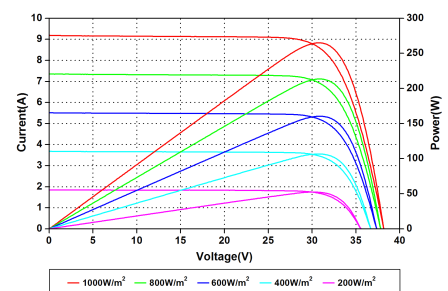

Current-Voltage and Power-Voltage Curves at Different Irradiances

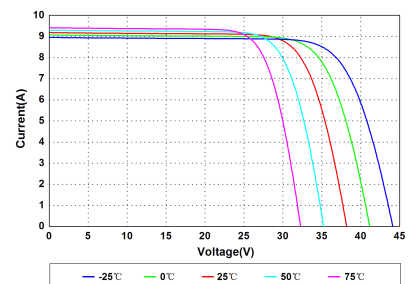

Current-Voltage Curves at Different Temperatures

Specifications in this datasheet are subject to change without prior notice.