

## Mono Crystalline Solar Module -6 inch\*60

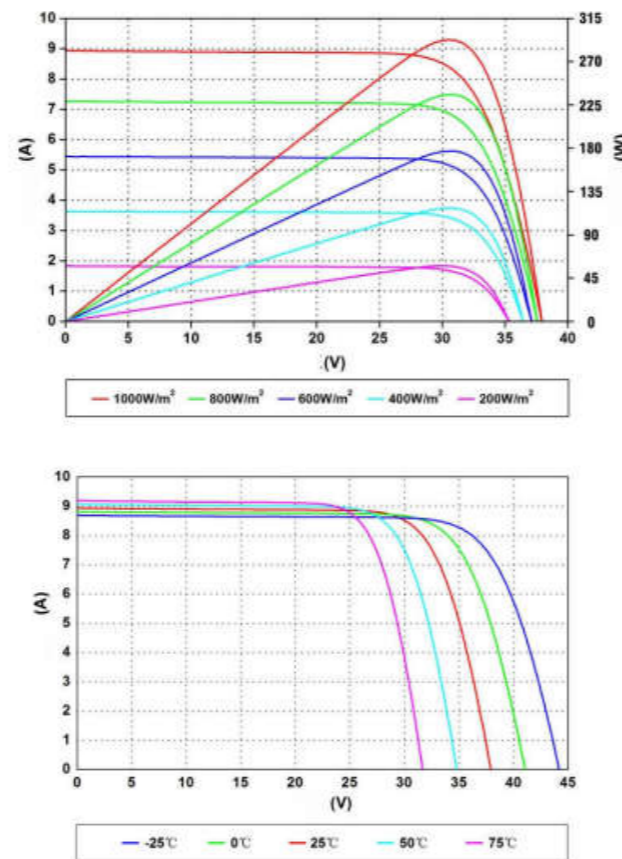
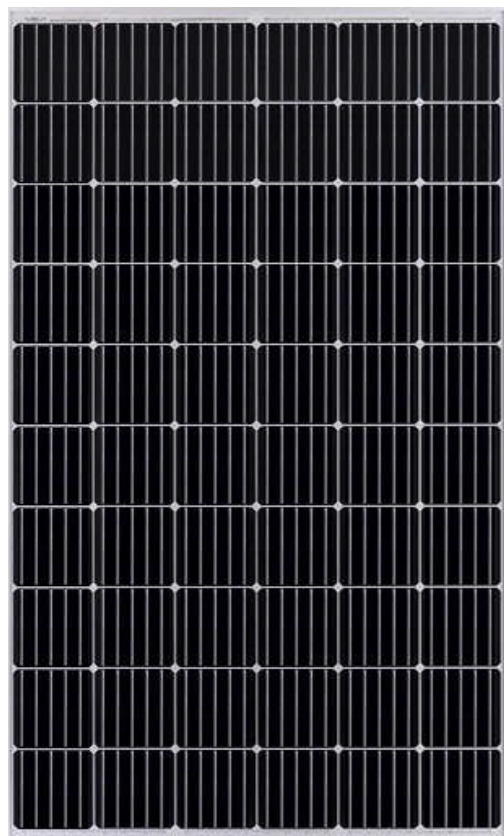

### Electrical characteristics at Standard Test Conditions (STC)

Model	SA315-60M	SA320-60M	SA325-60M	SA330-60M	SA335-60M	SA340-60M
Max Power - Pmpp (W)	315	320	325	330	335	340
Positive power tolerance (%)	0-5W	0-5W	0-5W	0-5W	0-5W	0-5W
Open Circuit Voltage - Voc (V)	41.54	41.88	42.21	42.43	42.81	43.04
Short Circuit Current - Isc (A)	9.84	9.92	9.99	10.10	10.16	10.26
Max Power Voltage-Vmpp (V)	33.82	34.10	34.36	34.54	34.86	35.04
Max Power Current - Imp (A)	9.31	9.38	9.45	9.55	9.61	9.70
Module Efficiency(%)	19.36	19.67	19.98	20.28	20.60	20.90

Electrical data relates to standard test conditions (STC): irradiance 1000 W/m<sup>2</sup>; AM 1.5; cell temperature 25°C measuring uncertainty of power is within 0-5W. Certified in accordance with IEC61215:2016, IEC61730-1/2:2016

### Electrical characteristics at Nominal Operating Cell Temperature (NOCT)

Model	SA315-60M	SA320-60M	SA325-60M	SA330-60M	SA335-60M	SA340-60M
Max Power - Pmpp (W)	231	234	238	241	245	248
Open Circuit Voltage - Voc (V)	37.66	37.89	38.26	38.36	38.70	38.93
Short Circuit Current - Isc (A)	7.98	8.03	8.09	8.19	8.23	8.28
Max Power Voltage-Vmpp (V)	30.29	30.47	30.79	30.98	31.33	31.51
Max Power Current - Imp (A)	7.63	7.68	7.73	7.78	7.82	7.87

Nominal Operating Cell Temperature (NOCT): Irradiance 800W/m<sup>2</sup>, environment temperature 20, wind speed 1m/s

### Temperature Characteristics

Voltage Temperature Coefficient	-0.36%/K
Current Temperature Coefficient	+0.04%/K
Power Temperature Coefficient	-0.36%/K

### Maximum Ratings

Maximum system voltage (V)	1500 V DC
Series fuse rating (A)	13A/15A
Reverse current overload (A)	25A

### Mechanical Characteristics

Dimensions	1640*992*35mm ( Length*Width*Depth )
Weight	18.0kg
Frame	Anodized aluminum profile ( Silvery/Black )
Front glass	White toughened safety glass, anti-reflective coating 3.2mm
Cell Encapsulation	EVA (Ethylene-Vinyl-Acetate)
Back sheet ( Black / White )	Fluorine containing composite film
Cells	6*10 pieces Mono solar cells series strings(6INCH/5BB)
Junction Box	Rated current ≥13A/15A, IP≥67/68
Cable	Length 900mm, 1×4mm <sup>2</sup>
Connector	MC 4/ compatible

Note : We accept customized solar modules , such as frame , backsheet colors , length of cables

### Packaging

Container 20	360PCS
Container 40	840PCS
Container 40HQ	952PCS

### Parameters

temp. Range	-40°C to 85°C
Application Class	Class A
Pollution Degree	1
Protection Class	Class II
Fire Rating	Class C

### Dimensions

Note: Module layout below only valid for modules with 35mm thickness. All dimensions in mm

- Cell efficiency > 22.5%
- EL Double Inspection
- 12 years Material&workmanship warranty
- 25 years Linear power output warranty
- diameter 25mm with 23m/s (standard )  
diameter 55mm with 33.9m/s (optional)
- front side 5400Pa (standard)  
front side 8000Pa & 12000Pa (optional)

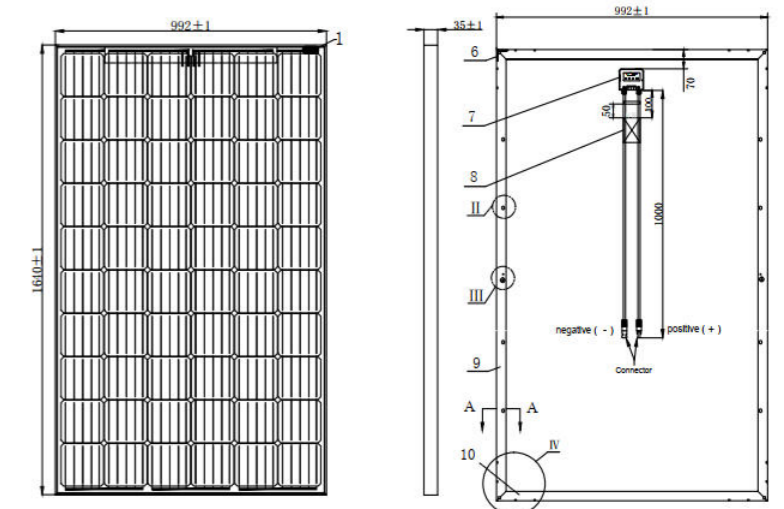

IEC61215-1:2016 IEC61215-1-1:2016 IEC61215-2:2016 IEC61730-1:2016 IEC61730-2:2016 EN61215-1:2016  
EN61215-2:2017 EN61215-1-1:2016 EN IEC61730-1:2018 EN IEC61730-2:2018 IEC61853-1:2011 IEC61701:2011  
IEC TS62804-1:2015 IEC62716:2013 EN50380:2003 KS C 8561:2016 IEC60068-2-68 LCS ISO9001:2015 ISO14001:2015

