

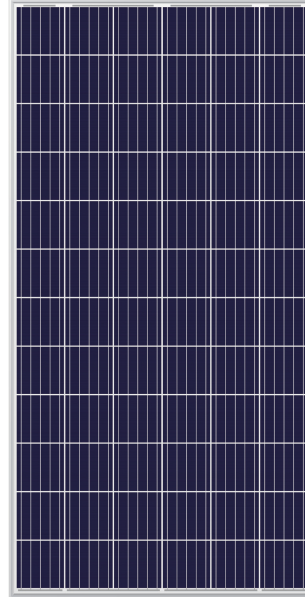

# BQ-6PA ( -HV ) 325-340<sub>w</sub>



## KEY FEATURES



Tested and certified according to newest IEC standard  
IEC61730-1:2016 IEC61215-1:2016  
IEC61730-2:2016 IEC61215-2:2016



Safety for salt mist corrosion  
Safety for ammonia corrosion



Bankable products



Outstanding power output capability at low irradiance



Triple 100% Electroluminescence (EL) tests minimize breakage rate



Top rank in Photon yield measurement



Safety for fire risk  
(Class C tested in TÜV SÜD and Rheinand)



Anti-PID products, passing TÜV SÜD system voltage durability test



World 1st company to pass "Thresher Test" and "On-site Power Measurement Validation" certificate

### Warranty

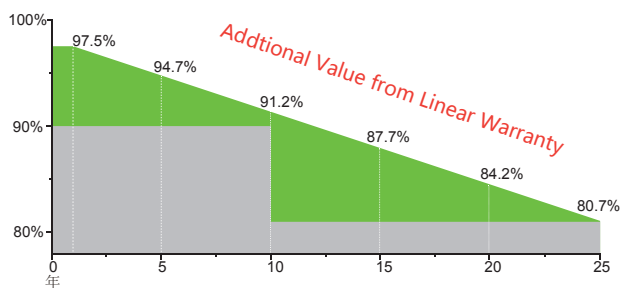

**10**  
Years

Guarantee on product material and workmanship

**25**  
Years

linear power output warranty

### Product Certificates



**BQ SOLARTECH CO., LTD**

+86 13758135482 sales@bqsolartech.com

www.bqsolartech.com

# Electrical Characteristics

Module Type	BQ-325-6PA-HV		BQ-330-6PA-HV		BQ-335-6PA-HV		BQ-340-6PA-HV	
	STC	NOCT	STC	NOCT	STC	NOCT	STC	NOCT
Maximum Power $-P_{mp}$ (W)	325	240	330	244	335	248	340	252
Open Circuit Voltage $-V_{oc}$ (V)	45.7	42.2	45.9	42.4	46.2	42.6	46.4	42.8
Short Circuit Current $-I_{sc}$ (A)	9.03	7.30	9.12	7.37	9.20	7.43	9.30	7.49
Maximum Power Voltage $-V_{mp}$ (V)	37.3	34.8	37.5	35.0	37.7	35.3	37.9	35.5
Maximum Power Current $-I_{mp}$ (A)	8.72	6.89	8.80	6.98	8.89	7.02	8.98	7.10
Module Efficiency STC- $\eta_m$ (%)	16.75/16.63		17.01/16.89		17.26/17.15		17.52/17.40	
Power Tolerance (W)	(0,+4.99)							
Maximum System Voltage (V)	1500 VDC							
Maximum Series Fuse Rating (A)	20A							
Pmax Temperature Coefficient	-0.36 %/°C							
Voc Temperature Coefficient	-0.30 %/°C							
Isc Temperature Coefficient	+0.05 %/°C							
Operating Temperature	-40~ +85 °C							
Nominal Operating Cell Temperature	45±2 °C							

STC: Irradiance 1000 W/m<sup>2</sup> module temperature 25°C AM=1.5

NOCT: Irradiance 800 W/m<sup>2</sup> ambient temperature 20° C wind speed :1m/s Power measurement tolerance: +/-3%

## I-V Curve

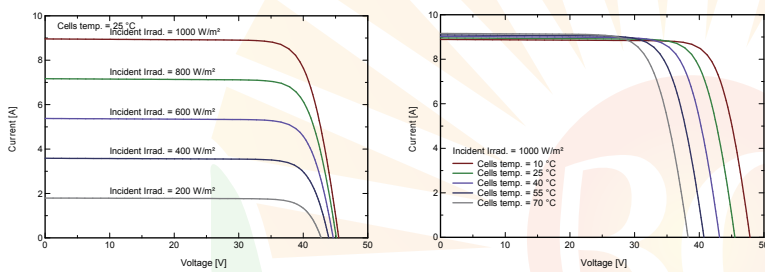

## Technical drawing(BQ-XXX-6PA)

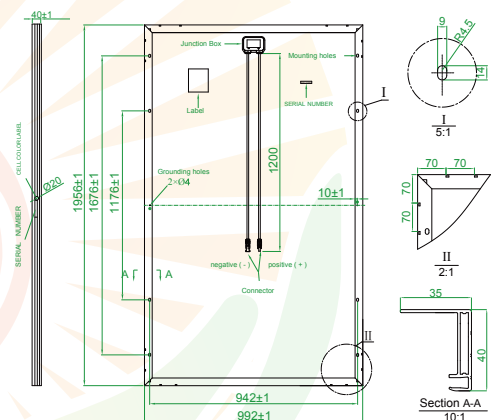

## Mechanical Specifications

External Dimension	1956x 992 x 40mm/1970x 992 x 40mm
Weight	21.5kg/22.0kg
Solar Cells	Poly crystalline 156.75 x 156.75 mm (72pcs)
Front Glass	3.2 mm AR coating tempered glass, low iron
Frame	Anodized aluminium alloy
Junction Box	IP68, 3 diodes
Output Cables	4.0 mm <sup>2</sup> , cable length:1200 mm
Connector	MC4 Compatible
Mechanical Load	5400 Pa

## Technical drawing(BQ-XXX-6PA-HV)

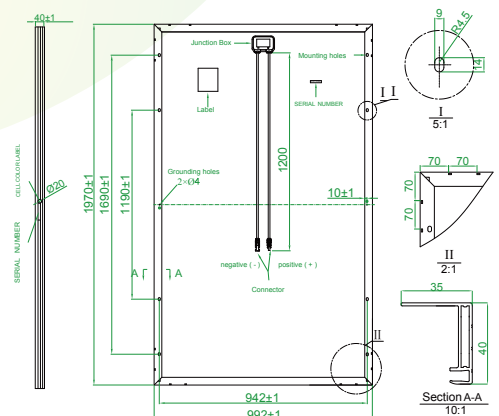

## Packing Configuration

External Dimension	1956 x 992 x 40mm/1970x 992 x 40mm		
Container	20' GP	40' GP	40' HQ
Pieces per Pallet	27	27	27+2*
Pallets per Container	10	22	22
Pieces per Container	270	594	638

\* 27+2 pieces per pallet is the special package which only suits for container transport.For details,please consult SERAPHIM.

\* All Dimensions in mm.

\* The above drawing is a graphical representation of the product.

**BQ SOLARTECH CO., LTD**

+86 13758135482 sales@bqsolartech.com

www.bqsolartech.com