

**PERFECT
MANAGEMENT
OF ENERGY
PRODUCTION,
STORAGE AND
CONSUMPTION**

2.4 / 3 / 5 / 6

The Ingecon® Hybrid AC Link single-phase inverter complies with the most demanding international standards.

Energy management

The Ingecon® Hybrid AC Link operates as a power manager, guaranteeing the correct balance between production, storage and consumption, by connecting and controlling an auxiliary generator should this be required.

Maximum compatibility

The inverter creates a single-phase AC grid that makes it possible to integrate the PV and wind renewable energy production, by combining it with the Ingecon® Sun 1Play and Ingecon® µWind inverters. It also incorporates an integrated RS-485 communication link.

Battery management

The Ingecon® Hybrid AC Link features a highly advanced battery control technology that ensures the maximum life of the storage system. The battery temperature is controlled at all times by means of a three-wire PT100 sensor.

Stand-alone systems

The Ingecon® Hybrid AC Link can create single-phase and three-phase stand-alone systems. The system power can be increased by connecting a number of Ingecon® Hybrid AC Link inverters in parallel.

Standard 3 year warranty, extendable for up to 25 years

PROTECTIONS

- AC overvoltages.
- DC overvoltages.
- Shortcircuits and overloads at the output (configurable).
- Insulation faults.
- Galvanic isolation between the DC and AC sides.

OPTIONAL ACCESSORIES

- Remote GSM/GPRS communication via modem.
- Configurable potential free contact.

ACCESSORIES BY DEFAULT

- Potential free contact for connection and disconnection the back-up generator.
- PT100 (3-wire) battery temperature measurement.



Size and weight (mm)

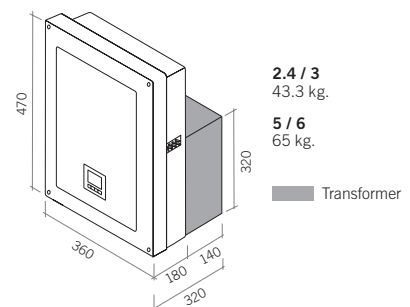

	2.4	3	5	6
Input (DC)				
Battery voltage	48 - 250 V	60 - 250 V	96 - 250 V	120 - 250 V
Charge / discharge current	50 A	50 A	50 A	50 A
Battery type	Lead, Ni-Cd, Li-ion	Lead, Ni-Cd, Li-ion	Lead, Ni-Cd, Li-ion	Lead, Ni-Cd, Li-ion
Input (AC)				
Rated voltage	230 V	230 V	230 V	230 V
Voltage range	170 - 265 V	170 - 265 V	170 - 265 V	170 - 265 V
Rated frequency	50 - 60 Hz	50 - 60 Hz	50 - 60 Hz	50 - 60 Hz
Frequency range	40 - 70 Hz	40 - 70 Hz	40 - 70 Hz	40 - 70 Hz
Charge current range	0 - 14 A	0 - 14 A	0 - 26 A	0 - 26 A
Generator or grid maximum power	6,000 W	6,000 W	11,000 W	11,000 W
Output (AC)				
Rated power AC	2,400 W	3,000 W	5,000 W	6,000 W
AC power (25°C) 1min/3s	3,000 W / 3,150 W	3,750 W / 3,940 W	6,250 W / 6,560 W	7,500 W / 7,870 W
Maximum AC current	14 A	13 A	22 A	26 A
Rated AC voltage	230 V	230 V	230 V	230 V
Rated AC frequency	50 - 60 Hz	50 - 60 Hz	50 - 60 Hz	50 - 60 Hz
Efficiency				
Maximum efficiency	94%	94%	94.5%	94.5%
General Information				
Stand-by consumption	<10 W	<10 W	<10 W	<10 W
Operating temperature	-20°C to +50°C	-20°C to +50°C	-20°C to +50°C	-20°C to +50°C
Relative humidity	0 - 95%	0 - 95%	0 - 95%	0 - 95%
Protection class	IP 65	IP 65	IP 65	IP 65

Compliance with standards: EN62109-1, EN62109-2, EN61000-6-2, EN61000-6-3, RD1699/2011, P.O.12.3, VDE-AR-N4105, CEI0-21, CEI11-20, VDE0126-1-1, G83/1-1.

Wiring diagram

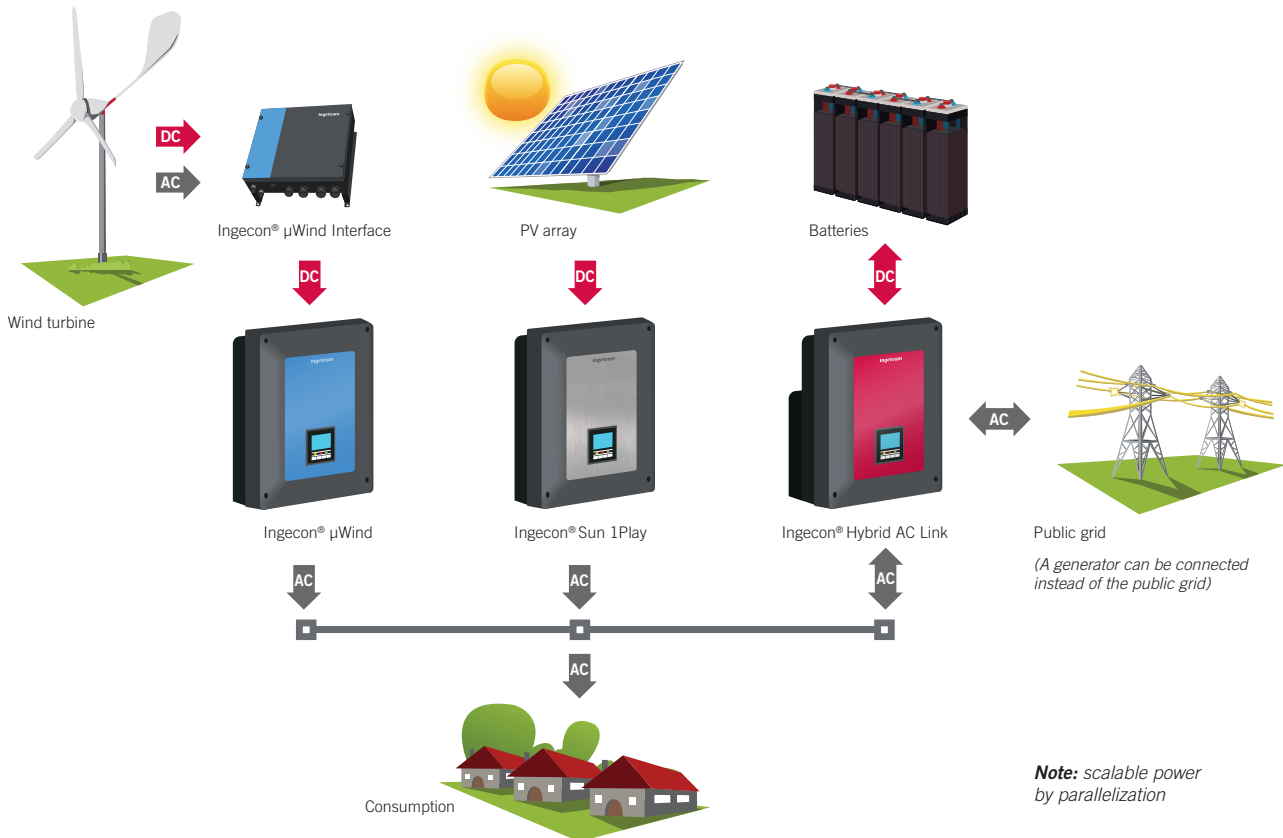

Note: scalable power by parallelization