

PVmaster Compact Station

PVMCS-45-0540 and PVMCS-50-0610

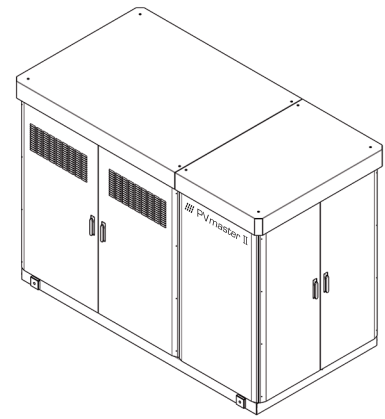

- PVmaster Compact Station for direct connection to a medium voltage transformer
- MPP voltage range 450 V to 850 V or 500 V to 850 V
- Applicable with all common module types
- Maximum efficiency >98 %
- Integrated air/liquid heat exchanger with pump
- Different operating modes (Multi MPPT is shown)

Technical data

Designation	PVMCS-45-0540	PVMCS-50-0610
Generator connection (DC)		
Recommended PV generator output ¹⁾	2 x 300 kWp	2 x 335 kWp
Min./max. input voltage ($V_{dc\ min} / V_{dc\ max}$)	450 V / 900 V	500 V / 900 V
MPP voltage range ($V_{mpp\ min}$ to $V_{mpp\ max}$)	450 V bis 850 V	500 V bis 850 V
Max. input current ($I_{dc\ max}$)	2 x 618 A	2 x 629 A
Rated input voltage ($V_{ac,r}$)	500 V	550 V
Start voltage supply ($V_{dc\ start}$) ²⁾	510 V	565 V
Number of MPP trackers ³⁾	2	2
Termination technique flat terminal (L+, L-)	M12	
Mains power connection (AC)		
Max. output power ($S_{ac,r}$) at $V_{ac,r}$	2 x 270 kVA	2 x 305 kVA
Rated power ($P_{ac,r}$) at $\cos\ \varphi = 1$	2 x 270 kW	2 x 305 kW
Rated voltage ($V_{ac,r}$) ⁴⁾	2 x 290 V	2 x 330 V
Min./max. output voltage ($V_{ac\ min} / V_{ac\ max}$)	In accordance with country-specific requirements	
Rated frequency (f_r)	50 Hz / 60 Hz	
Frequency range (f_{min} to f_{max})	In accordance with country-specific requirements	
Max. output current ($I_{ac\ max}$)	2 x 538 A	2 x 534 A
System form	In accordance with country-specific requirements	
Power factor $\cos\ \varphi$	Adjustable 0.8 ind. to 0.8 cap.	
Distortion factor (THD) at $P_{ac,r}$	<2.5 %	
Termination technique box terminal (L1, L2, L3)	120 mm ² to 300 mm ²	
Efficiency ⁵⁾		
Max. efficiency	>98 %	>98 %
European efficiency	>97,5 %	>97,5 %
CEC efficiency	>98 %	>98 %
Dimensions		
Height (excluding base, approx.)	1600 mm	
Width (approx.)	2500 mm	
Depth (approx.)	1300 mm	
Weight (approx.)	1450 kg	
General data		
Immediate vicinity	Outdoor installation	
Ambient temperature	-20 °C to +50 °C ⁶⁾	
Relative humidity	15 % to 85 %, condensation not permitted	
Cooling method	Regulated air/liquid cooling (self-contained system)	
Pollution severity (EN 60664-1)	2	
Power consumption		
Intrinsic consumption in active mode	<1 % rated power ($P_{ac,r}$)	
Standby power consumption ⁷⁾ / night	<200 W / 3 W	

1) At Module-STC in accordance with EN 60904-3

2) The actual DC start voltage is derived from the currently available PV generator output

3) Multi MPPT

4) Line-to-line voltage; other rated system voltages on request

5) Data referred to inverter excluding medium voltage transformer

6) Ratings up to 45 °C; power derating where appropriate at higher ambient temperatures

7) Without fan in passive mode

Data as per E EN 50524:2008-10

Technical data

Designation	PVMCS-45-0540	PVMCS-50-0610
Safety / Protective equipment		
Insulation monitoring of PV generator	Yes	
AC surge voltage protector / DC surge voltage protector	Optional / Yes	
Temperature monitoring	Temperature-dependent derating, shutdown at impermissible temperatures	
Overload response	Current limitation, operating point shift	
PV generator/mains decoupling	Electrical isolation by internal medium voltage transformer	
Isolation point	Yes	
Protection class (IEC 62103)	1	
Protection type (IEC 60529)	IP54	
Standards		
General	<ul style="list-style-type: none"> ■ CE conformity ■ Conforming to EEG 2009 ■ DIN EN 50178: Electronic equipment for use in power installations ■ DIN EN 61000-6-2 and DIN EN 61000-6-4: Electromagnetic compatibility ■ DIN EN 61439-1: Low voltage switchgear assemblies ■ DIN EN 50274: Low voltage switchgear assemblies - Protection against electric shock ■ DIN EN 61000-3-12: Limits for harmonic currents produced by equipment connected to public low-voltage systems with input current >16 A and ≤75 A per phase ■ BDEW (Bundesverband der Energie- und Wasserwirtschaft e. V. - Federal Energy and Water Management Association) guidelines: Guidelines for connection and parallel operation of generating plants on medium voltage networks, issued 06/2008, and regulations and transition periods for specific requirements supplementary to the technical guidelines, issued 02/2011. 	
System monitoring	In accordance with country-specific requirements	
Interfaces / Features / Options		
Interfaces	<ul style="list-style-type: none"> ■ Ethernet (RJ45) ■ µSD card ■ Digital outputs as floating contacts (24 V to 230 V, AC/DC, changeover contact) ■ Digital inputs with extended-range actuation coils (24 V to 230 V, AC/DC) ■ S0 pulse inputs ■ Analog inputs (0 V to +10 V / -10 V to +10 V / 0 mA to 20 mA / 4 mA to 20 mA) ■ PT100 inputs ■ CAN (e.g. for string monitoring) ■ LTI InterCOM (cross-communication between multiple PVmaster II) 	
Features	<ul style="list-style-type: none"> ■ DC surge protector type 2 ■ DC main switch ■ AC short-circuit proofing ■ Insulation monitoring of PV generator ■ Web server with extensive functionality ■ Integrated data logger ■ Support for various online portals ■ Air/liquid heat exchanger with pump 	
Options	<ul style="list-style-type: none"> ■ DC surge protector type 1 + 2 ■ AC surge protector type 1 + 2 ■ PV generator earthing ■ GSM modem ■ Control unit with extensive functionality ■ Online monitoring of operational data ■ Trouble reports issued by e-mail or SMS ■ Service contract, service extension ■ Extended temperature range ■ LTI medium voltage transformer with integrated SF6 medium voltage substation ■ Different operating modes <p>Multi Master: parallel connected units (1 MPP-Tracker) Multi MPPT: two separate units (2 MPP-Tracker)</p>	