

Grid-Connected PV Inverter

EA33KTLSI / EA40KTLSI



Features

More Energy Generated

- Transformerless design, maximum conversion efficiency up to 98.6%, Europe efficiency up to 98.4%
- Three MPP inputs
- Gain maximum energy generated by shadowed PV cells
- Wide MPPT voltage range (320 ~ 900V), longer daily power generation time
- Intelligent MPPT algorithm
- The maximum power point tracking is not affected by abrupt change of illumination
- Accurate identification technology of power change
- Static MPPT is stable and accurate
- Wide operating temperature range (-25°C ~ +60°C), continuous power generation at full load in high temperature

High Reliability

- Long lifetime design of film capacitor, 25 years of designed service life for complete machine
- Natural heat dissipation, waterproof, dust resistance, salt fog resistance and corrosion resistance
- Active+passive islanding protection
- Multilayer, step-by-step overcurrent, overvoltage, overtemperature and short-circuit protections for software and hardware
- 6 strings fault monitoring with rapid positioning

Advanced Control Technology

- Double modulation of three level SPWM and SVPWM, natural and smooth switch
- Adaptive control, adapting to harsh weak power grids environment
- Harmonic current compensation, THD < 1%
- Supporting active and reactive power grid dispatch and SVG function at night
- LVRT function

Friendly and Flexible

- Status display with LED indicators, concise interface
- Built-in DC SPD and fuse, no need of DC combiner box, reducing cost for users
- DC shut-off circuit breaker for safe and convenient maintenance operating
- IP 65 protection level for outdoor use
- Wall mounting design, one-step forming of aluminum shell
- Standard RS485 / APP / GPRS / Wi-Fi / Bluetooth communications; Optional PLC viewing the system operation information

Efficiency Curve

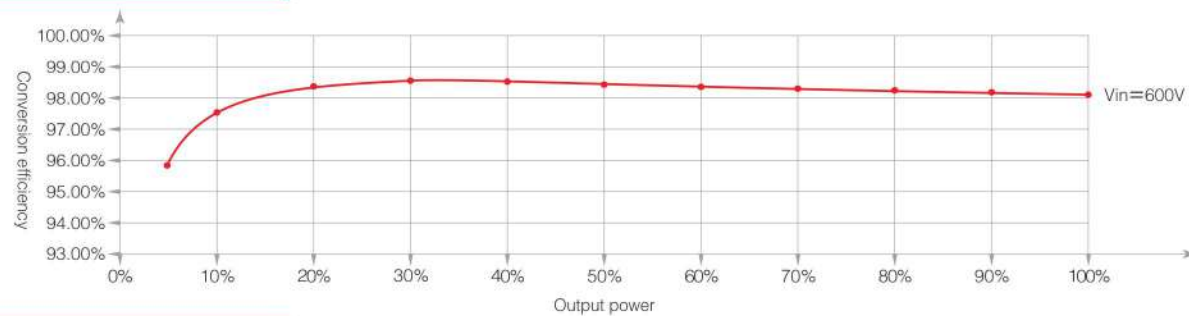

Schematic Diagram

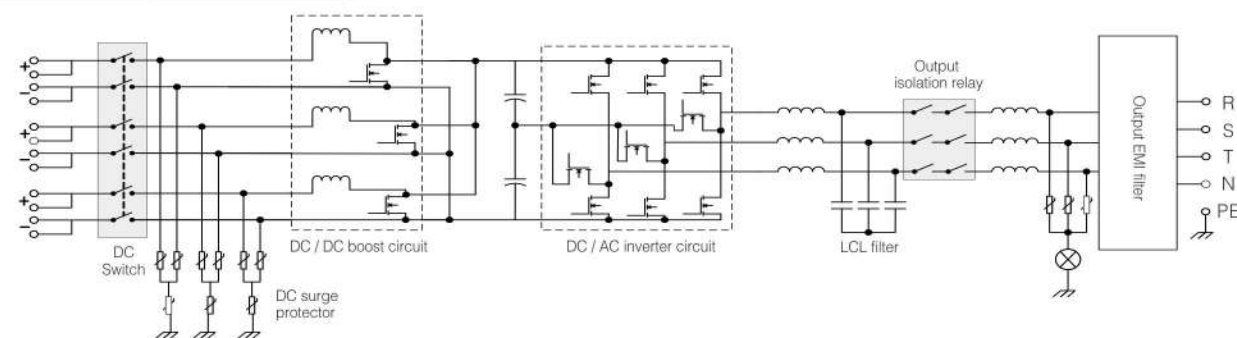

Technical Data

MODEL	EA33KTLSI	EA40KTLSI
INPUT (DC)		
Max. DC input power	33 kWp	40 kWp
Max. DC input voltage	1000 V	
Starting voltage	200 V	
Max. DC input current	3 × 23 A	
MPP voltage range	320 ~ 900 V	
Full-load MPP voltage range	480 ~ 800 V	580 ~ 850 V
Number of MPP inputs	3	
Rated DC input voltage	620 V	680 V
DC terminals	2 × 6	
MPPT efficiency (static)	> 99.9%	
Withstanding voltage & insulation for DC input against the enclosure	Basic insulation 3000 Vdc / 1 min	
OUTPUT (AC)		
Rated output power	30 KW	36 KW
Max. apparent power	33 KVA	40 KVA
Rated output voltage	3 × 380 / 400 / 415 Vac +N+PE	3 × 277 / 480 Vac +PE
Rated output current	3 × 45.9 A	
Max. allowable output current	3 × 48 A	
Rated frequency	50 Hz / 60 Hz	
DC component	< 0.5% (rated current)	
THD	< 3% (rated power)	
Power factor	0.8 leading ~ 0.8 lagging	
Withstanding voltage & insulation for AC output sides against the enclosure	Basic insulation 3000 Vdc / 1 min	
EFFICIENCY		
Max. inverter efficiency	98.7%	98.9%
Europe efficiency	98.4%	98.5%
PROTECTIONS		
Input reverse connection protection	Yes	
DC input switch	Yes	
DC overvoltage and overload protection	Yes	
Output AC short-circuit protection	Yes	
AC overload, overcurrent limitation and protection	Yes	
Grid over / under-voltage and unbalanced protection	Yes	
Grid over / under-frequency protection	Yes	
Leakage protection	Yes	
Lightning protection	Yes	
Islanding protection	Active and passive protection	
DC surge protection	Yes	
AC surge protection	Yes	
Insulation resistance detection protection	Yes	
CERTIFICATES AND APPROVALS		
Certificates	VDE / TUV / CE / CQC	
Grid-connected standard	TUV / VDE-AR-N-4105 / G59 / IEC 61727:2004 / IEC 62116:2014 / IEC 61683:1999	
EMC / safety	EN 61000-6-2, EN61000-6-3, EN 61000-3-2, EN 61000-3-3, EN 61000-3-11, EN 61000-3-12, EN / IEC 62109-1, EN / IEC 62109-2	
DISPLAY AND COMMUNICATIONS		
Display	LED / LCD / APP	LED / APP
RS485	Yes	
USB	Yes	
PLC	Optional	
APP and Bluetooth	Yes	
OTHERS		
Standby loss	< 15 W	
Topology	Transformerless	
MTBF	40000 h	
Warranty	5 years (standard), 10 / 15 / 20 / 25 years (optional)	
Operating temperature	-25 ° C ~ +60 ° C	
Cooling	Natural cooling	
Relative humidity	0 ~ 100% non-condensing	
IP rating	IP 65	
Max. operating altitude	3000 m	
Dimensions (W × D × H) (mm)	255 × 580 × 820	
Packaged dimensions (W × D × H) (mm)	690 × 935 × 365	
Net weight (kg)	68	
Gross weight (kg)	70	

Disclaimer:
 • These data in this document are tested under specified conditions. It may result in difference between actual results and these data due to some uncertain factors. The statement about this product is for reference only. It makes no representation or warranty.
 • All specifications subject to change without notice.