

SUN2000-50KTL-M0 Smart String Inverter



Smart I-V Curve
Diagnosis supported



Max. efficiency 98.7%



Fuse free design



Protection degree of IP65



12 strings intelligent
monitoring and fast
trouble-shooting



Type II surge arresters
for both DC and AC



Residual Current
Monitoring Unit (RCMU)
integrated



MBUS supported

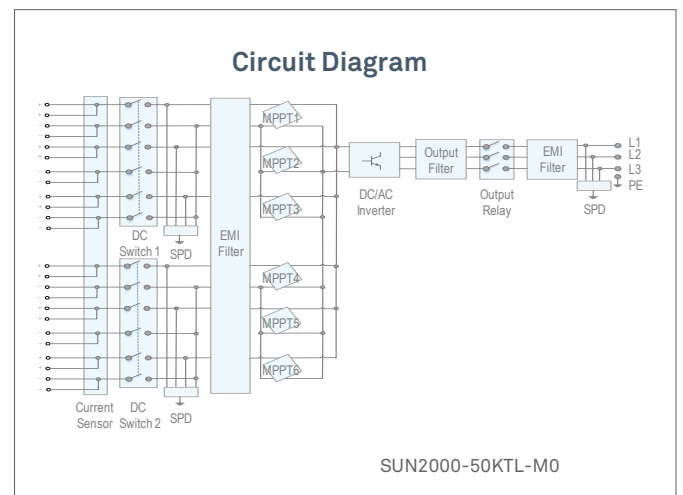
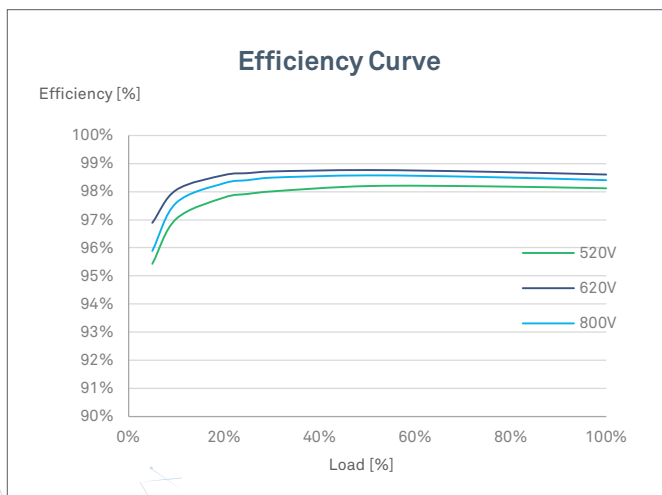

SUN2000-50KTL-M0

Technical Specification	SUN2000-50KTL-M0
Efficiency	
Max. Efficiency	98.7%
European Efficiency	98.5%
Input	
Max. Input Voltage	1,100 V
Max. Current per MPPT	22 A
Max. Short Circuit Current per MPPT	30 A
Start Voltage	200 V
MPPT Operating Voltage Range	200 V ~ 1,000 V
Rated Input Voltage	600 V
Number of Inputs	12
Number of MPP Trackers	6
Output	
Rated AC Active Power	50,000 W
Max. AC Apparent Power	55,000 VA
Max. AC Active Power (cosφ=1)	55,000 W
Rated Output Voltage	220 V / 230 V, default 3W + N + PE; 380 V / 400 V, 3W + PE
Rated AC Grid Frequency	50 Hz / 60 Hz
Rated Output Current	76 A @380 V / 72.2 A @400 V
Max. Output Current	83.6 A @380 V / 79.4 A @400 V
Adjustable Power Factor Range	0.8 LG ... 0.8 LD
Max. Total Harmonic Distortion	<3%
Protection	
Input-side Disconnection Device	Yes
Anti-islanding Protection	Yes
AC Overcurrent Protection	Yes
DC Reverse-polarity Protection	Yes
PV-array String Fault Monitoring	Yes
DC Surge Arrester	Type II
AC Surge Arrester	Type II
DC Insulation Resistance Detection	Yes
Residual Current Monitoring Unit	Yes
Communication	
Display	LED Indicators, Bluetooth + APP
RS485	Yes
USB	Yes
Monitoring BUS (MBUS)	Yes
General	
Dimensions (W x H x D)	1,075 x 555 x 300 mm (42.3 x 21.9 x 11.8 inch)
Weight (with mounting plate)	74 kg (163.1 lb.)
Operating Temperature Range	-25°C ~ 60°C (-13°F ~ 140°F)
Cooling Method	Natural Convection
Max. Operating Altitude	4,000 m (13,123 ft.)
Relative Humidity	0 ~ 100%
DC Connector	Amphenol Helios H4
AC Connector	Cable Gland + OT Terminal
Protection Degree	IP65
Topology	Transformerless
Standard Compliance (more available upon request)	
Certificate	EN 62109-1/-2, IEC 62109-1/-2, EN 50530, IEC 62116, IEC 62910, IEC 60068, IEC 61683
Grid Code	IEC 61727, G59/3, AS/NZS 4777.2, EN50438, VDE4105/0126