

SOLAR INVERTERS

ABB inverter station

PVS800-IS – 2.625 to 3.6 MW



The ABB inverter station is a compact turnkey solution designed for large-scale solar power generation. It houses all equipment that is needed to rapidly connect ABB central inverters to a medium voltage (MV) transformer station.

—
01

—
01 ABB inverter station, PVS800-IS, 2.625 to 3.6 MW

Turnkey solution for photovoltaic (PV) power plants

The ABB inverter station design capitalizes on ABB's long experience in the development and manufacture of secondary substations for electrical authorities and major end-users worldwide in conventional power transmission installations.

The station houses three ABB central inverters, PVS800 with embedded auxiliary power distribution, monitoring (optional) and air filtration system. It enables easy and rapid connection to a MV transformer station. Depending on the size of the PV power plant, several ABB inverter stations can be used to meet the capacity need.

Proven design with long operating life

The housing is based on a standard, insulated, steel-framed 40-foot shipping container. The total package weighs only 14 metric tons. The optimized

shipping container solution ensures cost-effective and safe transportability to the site. The station's optimized air circulation and filtering system together with thermal insulation enable operation in harsh temperature and humidity environments. The inverter station is designed for at least 25 years of operation.

Highlights

- Proven technology and reliable components
- Standard and robust design
- Protected working interior
- Modular and redundant system
- Embedded auxiliary power distribution system
- Double-stage air pre-filtering for reduced maintenance
- Extendable manufacturing footprint with fast deliveries
- Life cycle service and support through ABB's extensive global service network

ABB inverter station

Solar inverters

ABB's PVS800 central inverters are the result of decades of industry experience and the use of proven frequency converter technology. As such the central inverters provide a highly efficient and cost-effective way to convert the direct current generated by solar modules into high-quality and CO₂-free alternating current. Three ABB central inverters are used in this 40 feet ABB inverter station. The inverters provide high efficiency conversion with low auxiliary power consumption.



Easy connection to a MV station

The inverter station is easy to connect to any medium voltage station configuration to match specific country or project requirements. ABB can provide dry type transformers to go with a wide selection of switchgear configurations. Mounting options can be selected to match exactly the environmental and project-specific needs.

Embedded auxiliary power distribution system

The embedded auxiliary power supply system supports needs of both inverter and MV stations. The system includes protected power supply terminals for stations accessories and signal terminals for alarm and control sensors.

The embedded auxiliary transformer can be included if external power supply is not available at the plant.

Technical data and types

Type designation	PVS800-IS-2625kW-B	PVS800-IS-3000kW-C
Input (DC)		
Maximum input power ($P_{PV,max}$) ¹⁾	3 × 1050 kW	3 × 1200 kW
DC voltage range, mpp ($U_{DC, mpp}$)	525 to 825 V	600 to 850 V
Maximum DC voltage ($U_{DC,max}$)	1100 V	1100 V
Maximum DC current ($I_{DC,max}$)	3 × 1710 A	3 × 1710 A
Number of protected DC inputs	3 × 12 (+/-)	3 × 12 (+/-)
Number of mpp trackers	3	3
Output (AC)		
Nominal AC output power ($P_{AC,N}$) ²⁾	3 × 875 kW	3 × 1000 kW
Power at $\cos\phi = 0.95$ ²⁾	3 × 930 kW	3 × 950 kW
Maximum AC output power ($P_{AC,max}$) ³⁾	3 × 1050 kW	3 × 1200 kW
Nominal AC current ($I_{AC,N}$)	3 × 1445 A	3 × 1445 A
Nominal output voltage ($U_{AC,N}$)	350 V	400 V
Output frequency	50/60 Hz	50/60 Hz
Harmonic distortion, current ⁴⁾	<3%	<3%
Power factor compensation	Yes	Yes

¹⁾ Inverter limits power to safe level

²⁾ At 45 °C ambient temperature

³⁾ At 20 °C ambient temperature

⁴⁾ At nominal power

ABB inverter station design and power network connection

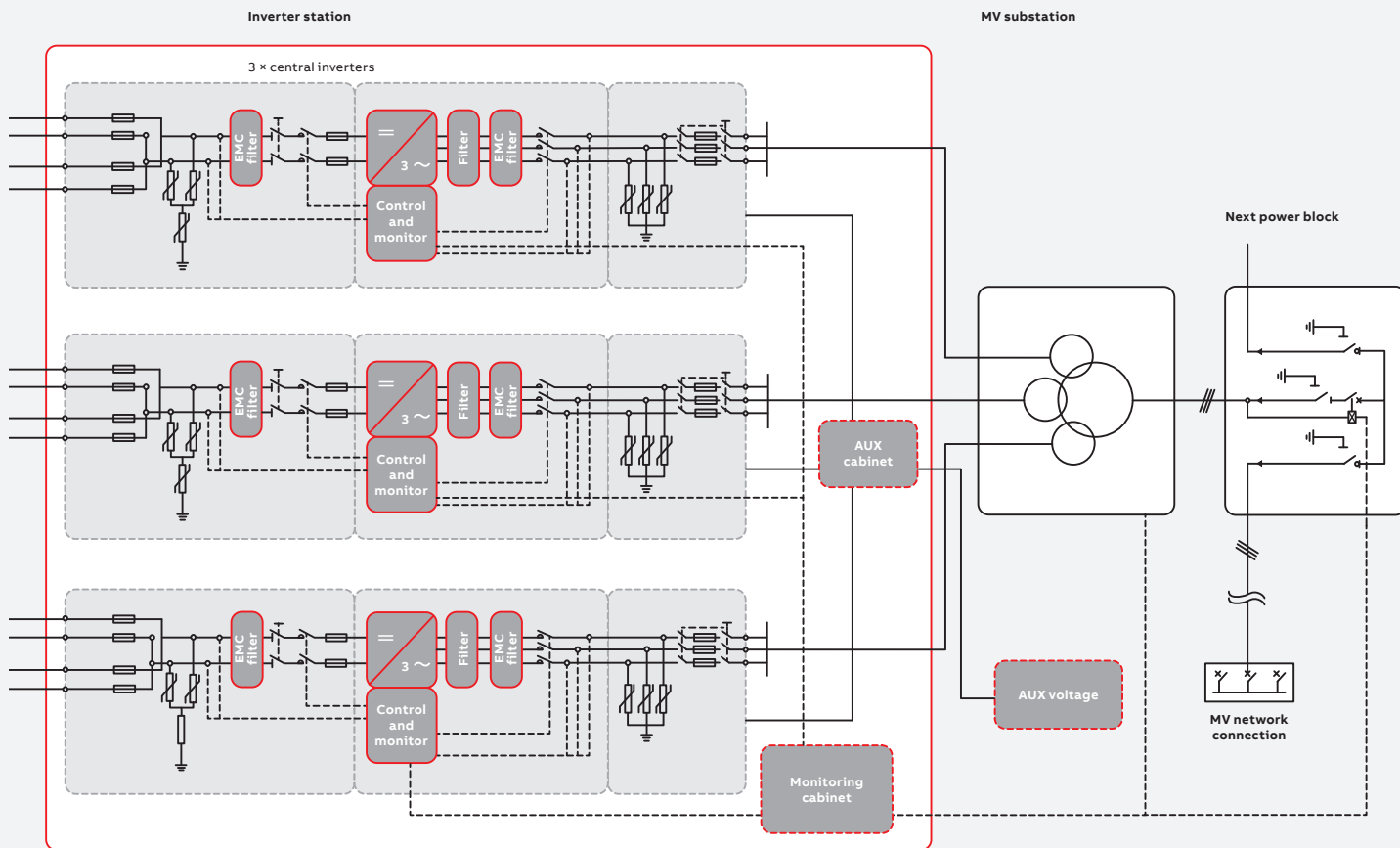

Technical data and types

Type designation	PVS800-IS-2625kW-B	PVS800-IS-3000kW-C
Efficiency⁵⁾		
Maximum	98.7%	98.8%
Euro-eta	98.5%	98.6%
Power consumption		
Own consumption in operation ⁶⁾	< 2000 W	
Standby operation consumption ⁶⁾	< 200 W	
Dimensions and weight		
Width/Height/Depth, (W x H x D)	12191 x 2896 x 2438 mm	
Weight approx.	< 14 t	
Environmental limits		
Degree of protection ⁷⁾	IP43	
Ambient temperature range (nominal ratings)	-15 °C to +45 °C	
Maximum ambient temperature ⁸⁾	+50 °C	
Relative humidity, non condensing	15 to 95%	

⁵⁾ Efficiency without auxiliary power consumption at min. UDC

⁶⁾ Without options and heating

⁷⁾ After installation. During transportation IP55.

⁸⁾ Power derating after 45 °C

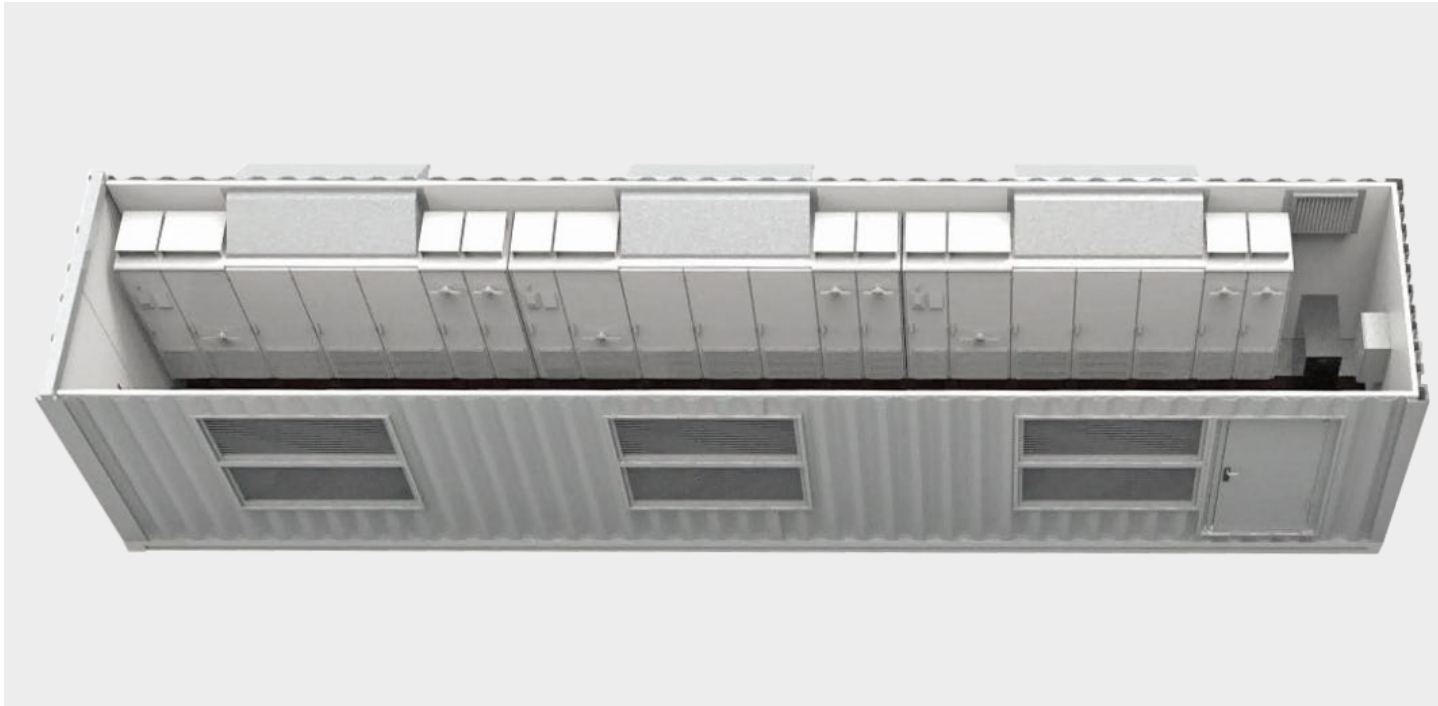

02

02 View to inside of ABB inverter station

Accessories

- Solar array junction boxes with string monitoring
- Remote monitoring solutions
- Warranty extensions
- Solar inverter care contracts

Options

- Auxiliary transformer
- Upgrades to match environmental conditions

Support and service

ABB supports its customers with a dedicated service network in more than 60 countries and provides a complete range of life cycle services from installation and commissioning to preventative maintenance, spare parts, repairs and recycling.

For more information please contact your local ABB representative or visit:

www.abb.com/solarinverters
www.abb.com

We reserve the right to make technical changes or modify the contents of this document without prior notice. With regard to purchase orders, the agreed particulars shall prevail. ABB does not accept any responsibility whatsoever for potential errors or possible lack of information in this document.

We reserve all rights in this document and in the subject matter and illustrations contained therein. Any reproduction, disclosure to third parties or utilization of its contents – in whole or in parts – is forbidden without prior written consent of ABB. Copyright © 2017 ABB. All rights reserved

