

智能并网逆变器GTB-600使用说明

参数表

型号	GTB-600	
最大输入功率	600Watt	
MPP跟踪电压	22-50V	
最小/最大启动电压	22-50V	
最大DC短路电流	30A	
最大输入工作电流	27.2A	
输出参数	@120V	@230V
输出峰值功率	600Watt	600Watt
额定输出功率	600Watt	600Watt
额定输出电流	5A	2.6A
额定电压范围	80-160VAC	180-280VAC
额定频率范围	48-51Hz/58-61Hz	48-51Hz/58-61Hz
功率因素	>99%	
每串电路连接台数	5台(单相)	10台(单相)
输出效率	@120V	@230V
MPP跟踪效率	99.5%	99.5%
最大输出效率	95%	95%
夜间损耗功率	<1W	<1W
总谐波失真	<5%	<5%
外观及技术特点		
工作温度范围	-40°C to +60°C	
尺寸(长×宽×高)	281mm×200mm×40mm	
重量	1.5kg	
防水等级	IP65	
散热方式	自冷	
通讯模式	Wi-Fi通讯	
电力传输模式	逆向传输, 负载优先使用	
监控系统	手机APP	
电磁兼容	EN50081_part1 EN50082_Party1	
电网扰动	EN61000-3-2 安规EN62109	
电网检测	DIN VDE 0126 UL1741	
证书	CE, BIS	

注意事项

- ★请按说明正确安装逆变器, 如有疑问请与相关人员联系。
- ★非专业人员请勿拆机, 只有合格的维修人员才可以修理本产品。
- ★请将逆变器安装在低湿度和通风良好的地方, 以避免逆变器过热, 并清除周围易燃易爆物品。
- ★使用本产品时, 避免小孩子触摸、玩耍, 以免触电。
- ★只能连接太阳能电池板。

产品配件

1. 用户手册1份;
2. 逆变器固定螺丝1包;
3. AC连接线1根;

LED显示说明

1. 红灯长亮3秒-----开机红灯长亮3秒, 设备进入正常工作状态;
2. 绿灯快闪-----MPPT搜索;
3. 绿灯慢闪-----MPPT+功率微调;
4. 红灯慢闪-----MPPT-功率微调;
5. 绿灯亮3秒, 灭0.5秒---MPPT锁定;
6. 红灯长亮-----a. 孤岛保护; b. 温度保护; c. AC电压过、欠压保护; d. DC电压过、欠压保护; e. 故障;

注:

正常工作指示灯闪烁过程: 逆变器连接上AC、DC端 → 红灯长亮3秒 → 绿灯快闪(MPPT搜索) → 绿灯慢闪(MPPT+功率微调)/红灯慢闪(MPPT-功率微调)/绿灯亮3秒, 灭0.5秒(MPPT锁定)。

逆变器安装指南

第一步 用本机附带的螺丝将逆变器安装固定在光伏板的支架上, 如下图所示:

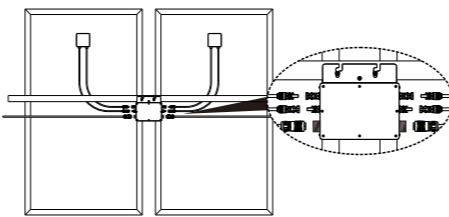

第三步 打开逆变器AC输出接头的防水盖并将AC连接线连接到AC防水插头上, 连接方法如插头连接图:

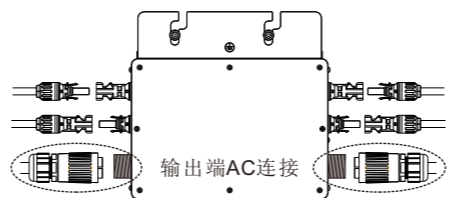

第四步 将AC输出线连接到AC主电缆上;

第五步 重复第一至第三步, 安装并连接好所有的逆变器;

第六步 将AC主电缆连接到市电电网。

第二步 将光伏板上的DC连接MC4插头正反负极连接到逆变器的DC输入端, 如下图所示:

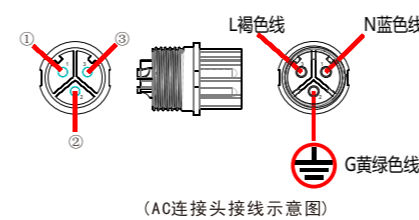
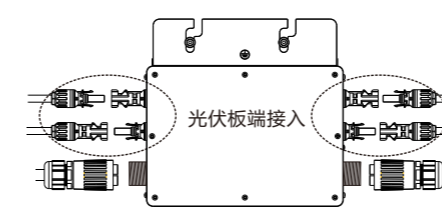

(AC连接头接线示意图)

智能光伏系统架构

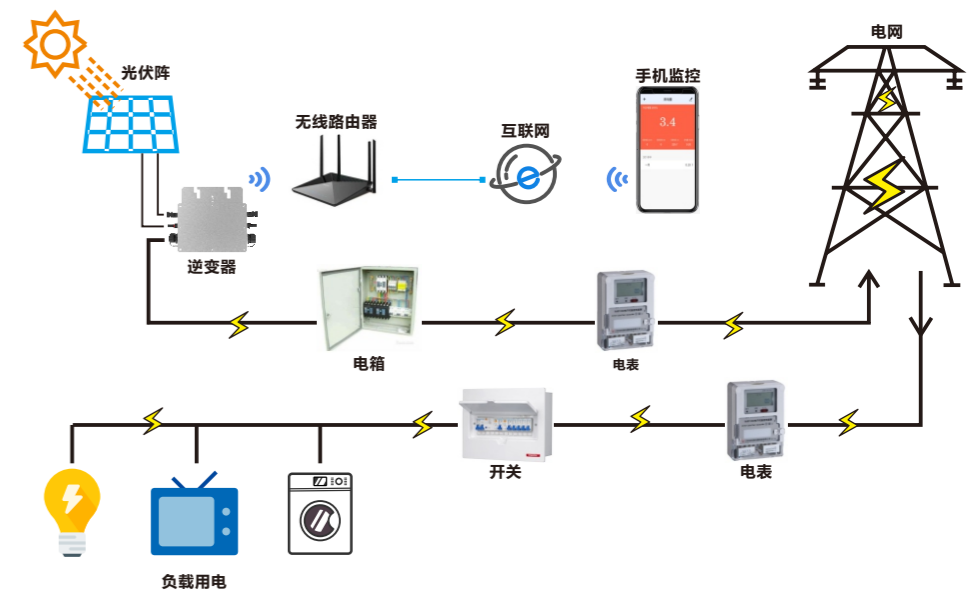

单相接法

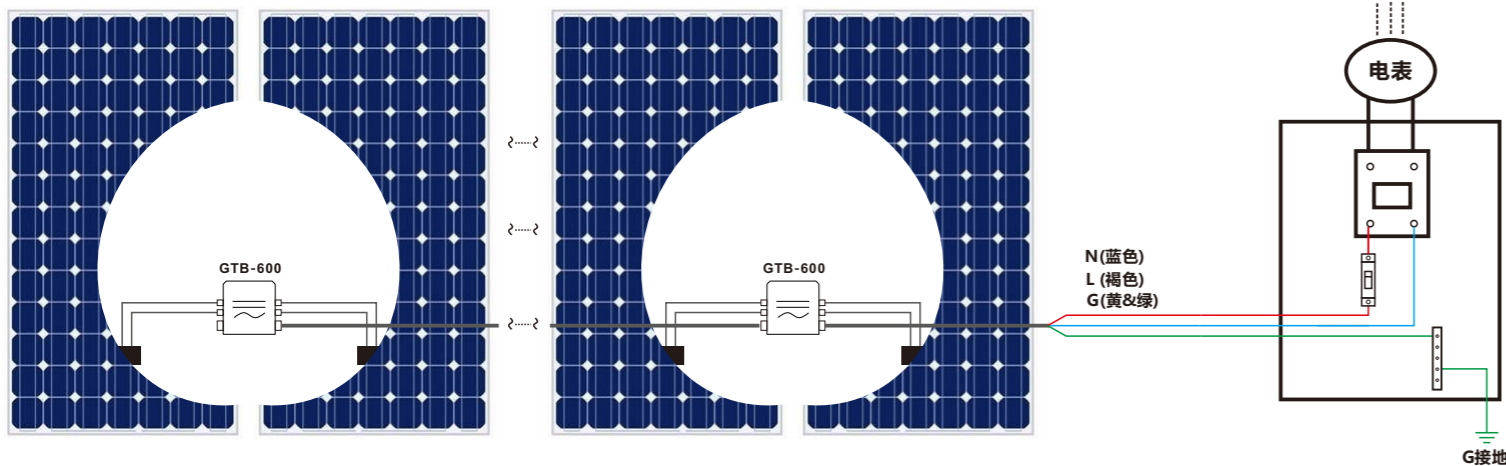

三相接法

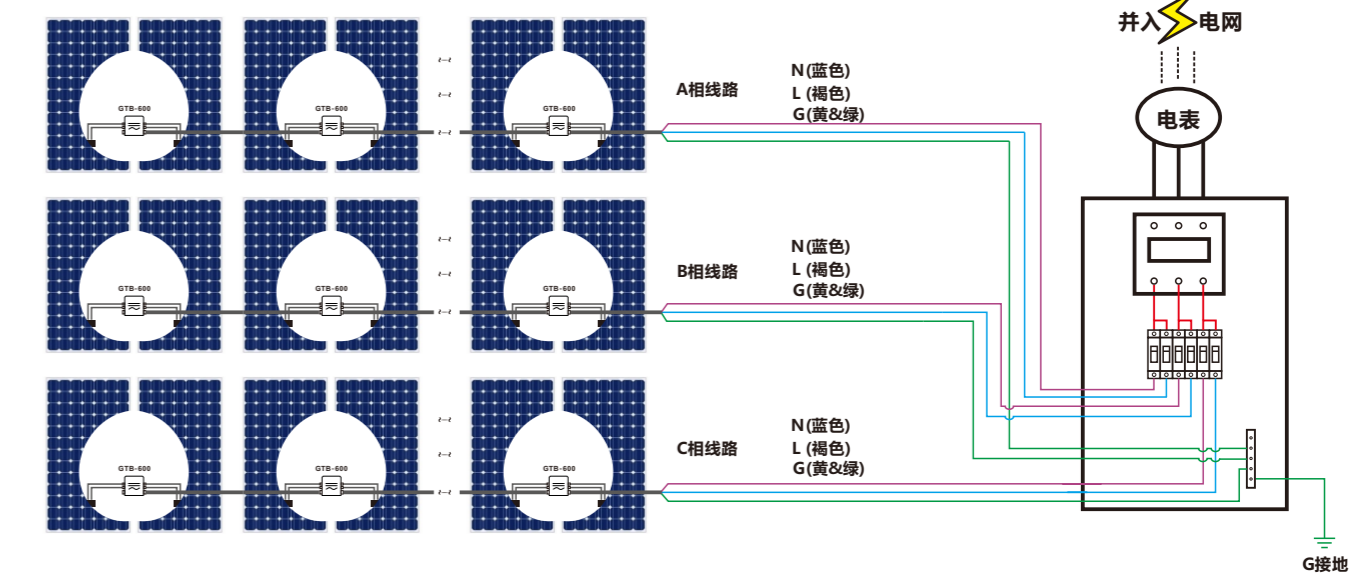

智能光伏监控系统操作步骤

- 1、下载并安装好监控系统APP (支持安卓及IOS系统)
- 2、点击创建新用户进行帐号创建
- 3、登陆帐号后请点击右上角【二维码扫描】功能键, 将逆变器身上的【二维码标贴】进行扫描,
- 4、提示输入家中的Wi-Fi密码时, 请输入Wi-Fi密码;
- 5、当输入完Wi-Fi密码后, 系统将进行配对连接 (如图5)
- 6、逆变器正确添加后, 并且光伏系统是在并网中正常运行时, 将显示为逆变器已开启 (如图6)
- 7、如逆变器没在当前网络中运行, 则显示为逆变器关闭 (如图7)
- 8、点击各台逆变器, 将可查看逆变器各项数据统计, 更多功能请在APP中点击进行查阅

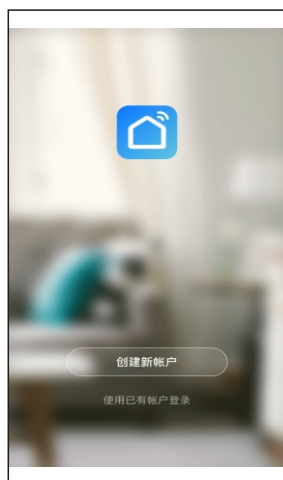

(图1)



(图2)



(图3)



(图4)



(图5)



(图6)



(图7)



(图8)

SMART GRID INVERTER GTB-600 Manual

Parameter Table

Model	GTB-600	
Maximum input power	600Watt	
Peak power tracking voltage	22-50V	
Min / max starting voltage	22-55V	
Maximum DC short-circuit	30A	
Maximum input operating current	27.2A	
Output Data	@120V	@230V
Peak power output	600Watt	600Watt
Rated output power	600Watt	600Watt
Rated output current	5A	2.6A
Rated voltage range	80-160VAC	180-260VAC
Rated frequency range	48-51/58-61Hz	48-51/58-61Hz
Power Factor	>99%	>99%
Max unit per branch circuit	5pcs (Single-phase)	10pcs (Single-phase)
Output Efficiency	@120V	@230V
Static MPPT efficiency	99.5%	99.5%
Maximum output efficiency	95%	95%
Night time power consumption	<1W	<1W
THD	<5%	<5%
Exterior & Feature		
Ambient temperature range	-40°C to +60°C	
Dimensions (L x W x H)	280mm x 200mm x 40mm	
Weight	1.62kg	
Waterproof rating	IP65	
Cooling	Self-cooling	
Communication Mode	WiFi mode	
Power transmission mode	Reverse transfer, load priority	
Monitoring System	Mobile APP, PC browser	
Electromagnetic Compatibility	EN50081.part1 EN50082.Party1	
Grid disturbance	EN61000-3-2 Safety EN62109	
Grid detection	DIN VDE 0126	
Certificate	CE, BIS	

Notes:

- ★Please connect the inverter following the operation instruction show above. If have any question please contact with relative persons.
- ★Non-professionals do not disassemble. Only qualified personnel may repair this product.
- ★Please install inverter in the low humidity and well-ventilated place to avoid the inverter over-heating and clear around the inflammable and explosive materials.
- ★When using this product, avoid children touching, playing, to avoid electric shock.
- ★Connected solar panels, battery or wind generators DC input DC power supply cable.

Accessories for product:

1. One warranty card;
2. One user manual;
3. One certificate of quality;
4. 1 pouch of screw for micro inverter installation;
5. One AC Cable;

LED Display

1. Red light 3 second---Red LED light 3 second while device starts, then in working condition;
 2. Green flash fast---MPPT searching;
 3. Green flash slow---MPPT + searching;
 4. Red flash slow---MPPT - searching;
 5. Green lights on 3s and off 0.5s---MPPT locked;
 6. Red light steady---a. Islanding protection; b. Over-temperature protection; c. Over / low AC voltage protection; d. Over / low DC voltage protection; e. Fault
- Remarks:
LED flashing in the process of being working condition: inverters connected to AC & DC sides → Red LED light 3 second → Green LED flash fast (MPPT searching) → Green LED flash slow (MPPT + searching) / Red LED flash slow (MPPT - searching) / Red LED lights on 3s and off 0.5s (MPPT locked).

Step1 Installation for fixed the inverter on the PV holder with the screws attached is as following:

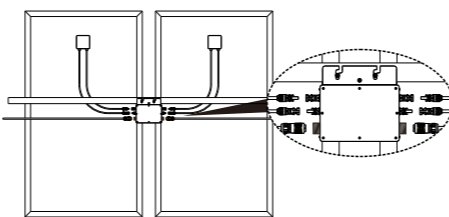

Step2 Connect the two DC terminal of the PV to the inverter, positive to positive, negative to negative. Show below:

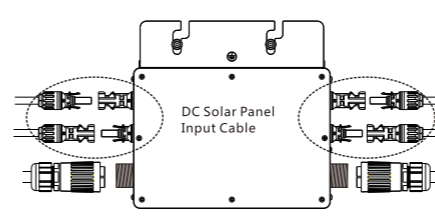

Step3 Open the waterproof cap on AC output side of the micro inverter, then plug to AC power line. Show below:

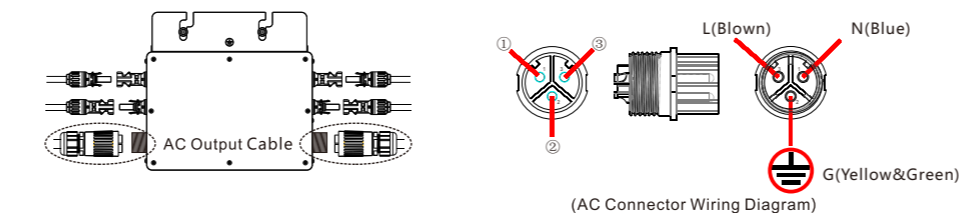

Step4 Plug the AC output line to main AC cable;

Step5 Repeat the first step to the third step to complete the installation of micro inverters;

Step6 Finally, please connect the AC main cable to the utility grid.

Structure of Solar power system

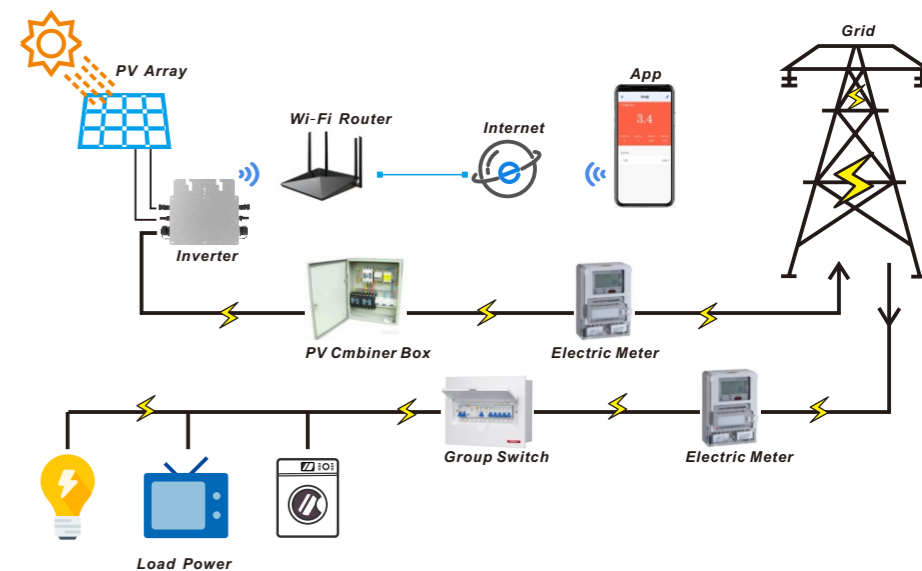

Single-Phase Connection

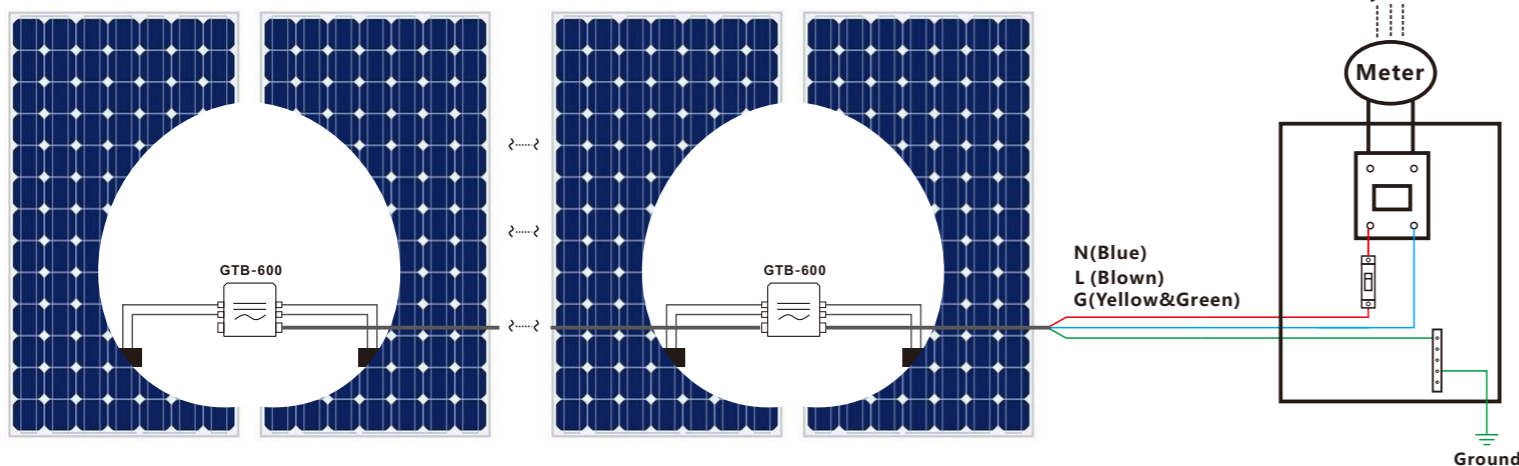

Three-Phase Connection

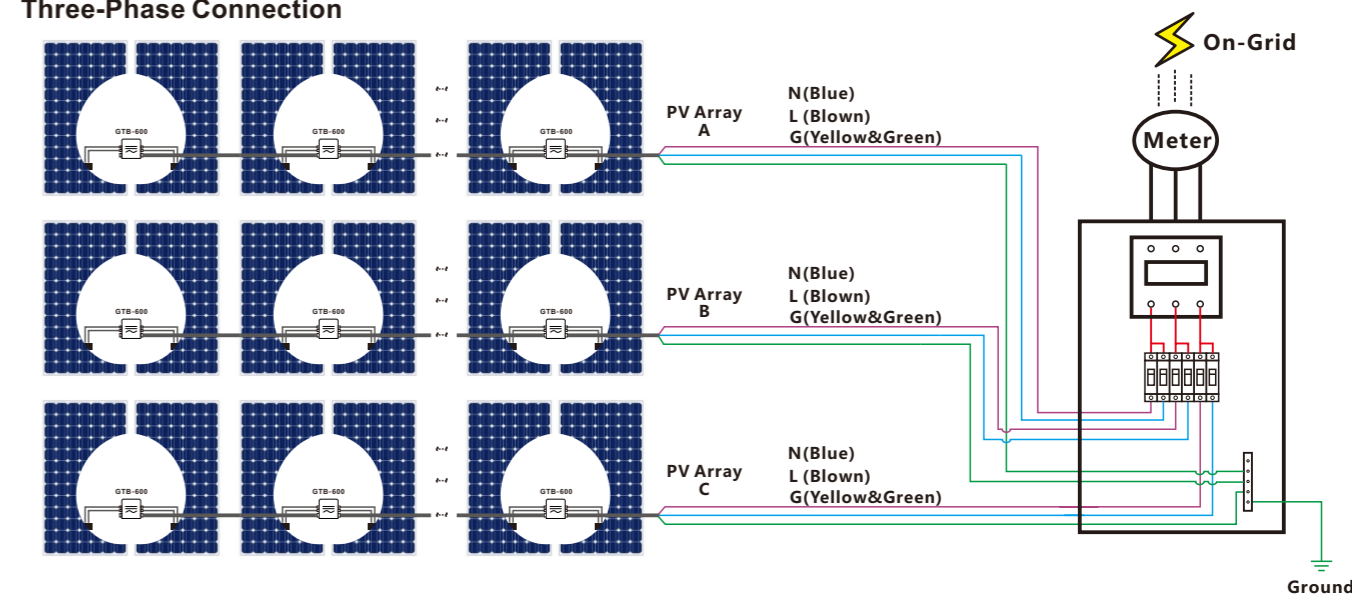

PV Monitoring System Operating Instructions

1. Download and install the monitoring system APP (support Android and IOS systems)
2. Click Create New User to create an account
3. Click [QR code scan] in the upper right corner to scan [QR code sticker] on the inverter
4. When prompted for the Wi-Fi password at home, please enter the Wi-Fi password;

5. After entering the Wi-Fi password, the system will perform pairing connection (see Figure 5)
6. After the inverter is added correctly, it will show that the inverter is turned on (see Figure 6)
7. If the inverter is not running in the current network, it will show that the inverter is off (see Figure 7)
8. Click on each inverter, you can view the statistics of the inverter

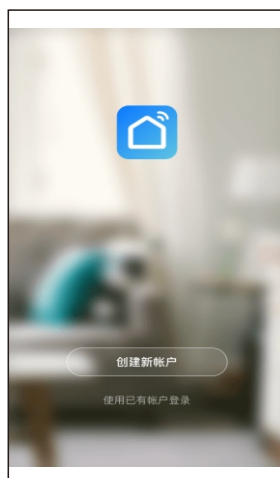

(1)



(2)



(3)



(4)



(5)



(6)



(7)



(8)