

SC2500HV-MV

Power Conversion System

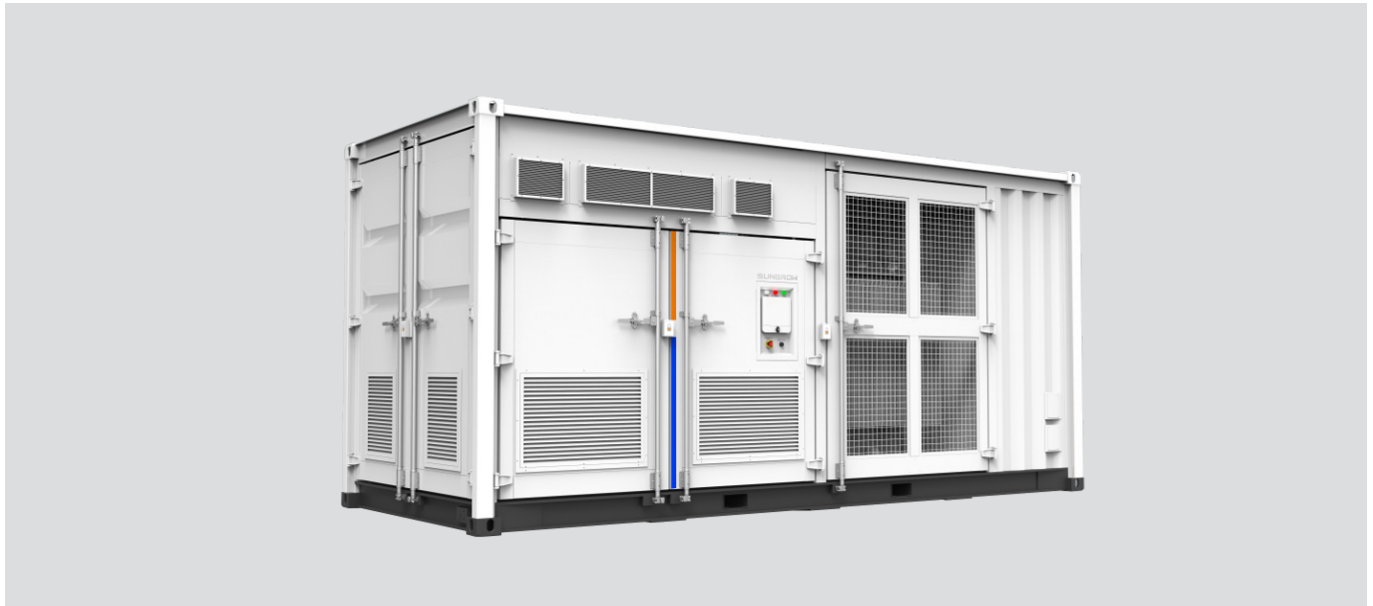

HIGH YIELD

- Advanced three-level technology,max. inverter efficiency 98.8%
- Effective forced air cooling,1.1 overload capacity,no derating up to 50°C
- Wide DC voltage operation window, full power operation at 1500V
- Supports two independent DC inputs

ESS APPLICATIONS

- Typical applications: peak shaving, energy shifting, frequency regulation, capacity firming
- Compatible with high voltage battery system, low system cost
- Bidirectional power conversion system with full fourquadrant operation
- Battery charge & dis-charge management and black start functions integrated

EASY O&M

- Integrated current & voltage monitoring function for online analysis and fast trouble shooting
- Low transportation and installation cost, due to 20-foot container design
- Modular design and all components front accessible, easy for maintenance
- Integrated auxiliary power supply panels for external devices

GRID SUPPORT

- Compliant with CE, IEC 62477, IEC 61000, SGSF
- Dynamic grid voltage and frequency support
- L/HVRT, L/HFRT, soft start/stop, specified power factor control and reactive power support

CIRCUIT DIAGRAM

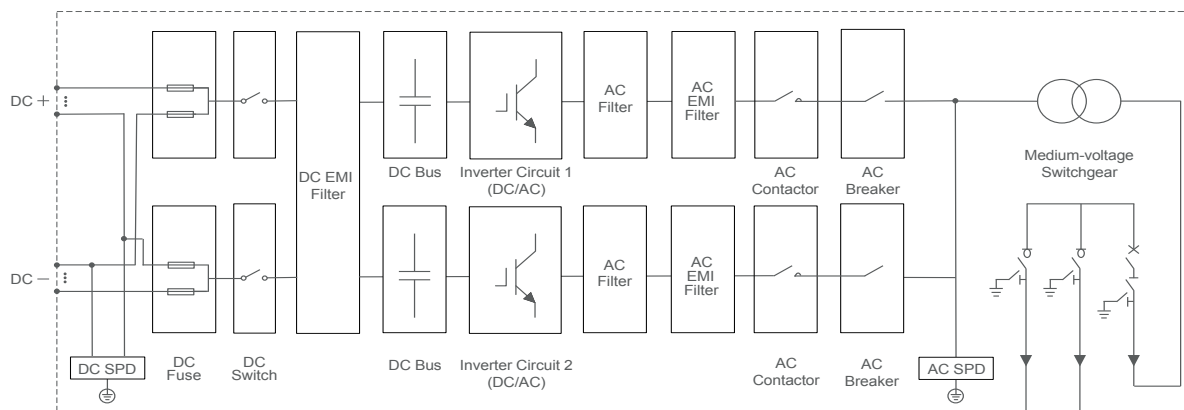

System Type	SC2500HV-MV
DC Side	
Max. DC voltage	1500 V
Min. DC voltage	800V
DC voltage range for nominal power	800 – 1500 V
Max. DC current	3508 A
Max. DC power	2806kW
No. of DC inputs	1 or 2 optional
AC Side (Grid)	
AC output power	2750 kVA @ 45 °C / 2500 kVA @ 50 °C
Max.inverter output current	2886 A
AC voltage range	10 – 35 kV
Nominal grid frequency / Grid frequency range	50 Hz / 45 – 55 Hz, 60 Hz / 55 – 65 Hz
THD	< 3 % (at nominal power)
DC current injection	< 0.5 % In
Power factor at nominal power / Adjustable power factor	> 0.99 / 1 leading – 1 lagging
Adjustable Reactive power	-100% – 100%
Feed-in phases / Connection phases	3 / 3
AC Side (Off-Grid)	
Inverter port nominal AC voltage	550 V
Inverter port AC voltage range	484 – 625V
AC voltage Distortion	< 3 % (Linear load)
DC voltage component	< 0.5 % Un (Linear balance load)
Unbalance load Capacity	100%
Nominal Voltage frequency / Voltage frequency range	50 Hz / 45 – 55 Hz, 60 Hz / 55 – 65 Hz
Efficiency	
Inverter Max. efficiency / Inverter European efficiency	98.8 % / 98.5 %
Transformer	
Transformer rated power	2500kVA
Transformer max. power	2750kVA
LV/MV voltage	0.55 kV / 10 – 35 kV
Transformer vector	Dy11
Transformer cooling type	ONAN(Oil Natural Air Natural)
Oil type	Mineral oil(PCB free) or degradable oil on request
Protection	
DC input protection	Load break switch + fuse
inverter output protection	Circuit breaker
AC output protection	Circuit breaker
Overvoltage protection	DC Type II / AC Type II
Grid monitoring / Ground fault monitoring	Yes / Yes
Insulation monitoring	Yes
Overheat protection	Yes
General Data	
Dimensions (W*H*D)	6058*2896*2438 mm
Weight	17 T
Degree of protection	IP54
Auxiliary power supply	220 Vac, 1.5 kVA / Optional: 480 Vac,30 kVA
Operating ambient temperature range	-30 to 60 °C (> 50 °C derating)
Allowable relative humidity range	0 – 95 % (non-condensing)
Cooling method	Temperature controlled forced air cooling
Max. operating altitude	1000 m(standard) / > 1000 m (optional)
Display	Touch screen
Communication	Standard: RS485, CAN, Ethernet; Optional: optical fiber
Compliance	CE, IEC 62477, IEC 61000, SGSF
Grid support	L/HVRT, L/HFRT, active & reactive power control and power ramp rate control