



**Deep Cycle Series Battery**

NPD series VRLA batteries are superior deep cycle design with thick plates, high-density active materials And Slightly stronger electrolyte, Which can withstand repeated deep cyclic applications. Deep cycle series Batteries are the special design batteries with 10 years floating design life at 25°C. Meet with IEC, BS, JIS and Eurobat standard.

**Application**

- \*Emergency Power System
- \*Communication equipment
- \*Telecommunication systems
- \*Uninterruptible power supplies
- \*Electric bicycle and wheelchairs, etc.
- \*Power tools
- \*Golf cars and buggies
- \*Marine equipment
- \*Solar and wind power system



**General Features**

- \*Safety Sealing
- \*Non-spillable construction
- \*High power density
- \*Excellent recovery from Deep discharge
- \*Thick plates and high active materials
- \*Longer Life and low self-discharge design

**Construction**

- \*Positive .....Lead dioxide
- \*Electrolyte .....Sulfuric acid
- \*Separator .....Fiber glass
- \*Container .....ABS(UL94-HB), Flammability Resistance of UL94-V2 can be available upon request
- \*Negative .....Lead
- \*Safety Valve .....EPDR
- \*Terminal .....Copper

**Specification**

Battery Model	Nominal Voltage		12V	
	Rated capacity(10 Hour rate)		40Ah	
Dimensions	Length	Width	Height	Total Height
	197mm (7.76 inches)	166mm(6.54inches)	174mm(6.85 inches)	181mm(7.13inches)
Approx Weight	13.5kg(29.77lbs)±3%			
Capacity 25°C (77°F)	10 hour (4.0A,10.8V)	5 Hour ( 6.8A,10.5V)	3Hour (10.0A,10.2V)	1 Hour (22.0A,9.6V)
	40.0Ah	34.0Ah	30.0Ah	22.0Ah
Max. discharge current	400A(5 Sec.)			
Internal Resistance	Full charged at 25 °C: Approx 8.1mΩ			
Capacity affected by Temp. (10 HR)	40°C (104 °F)	25°C (77°F)	0°C (32°F)	-15°C (5°F)
	102%	100%	85%	65%
Self Discharge at 25°C (77°F)	After 3 months storage		After 6 months storage	After 12 months storage
	91%		82%	64%
Charge method 25°C (77°F)	Cycle Use		Float Use	
	14.1-14.4V (Initial charging current less than 16.0A)		13.50-13.80V	

**Outer dimensions (mm)**

**Terminal Type (mm)**

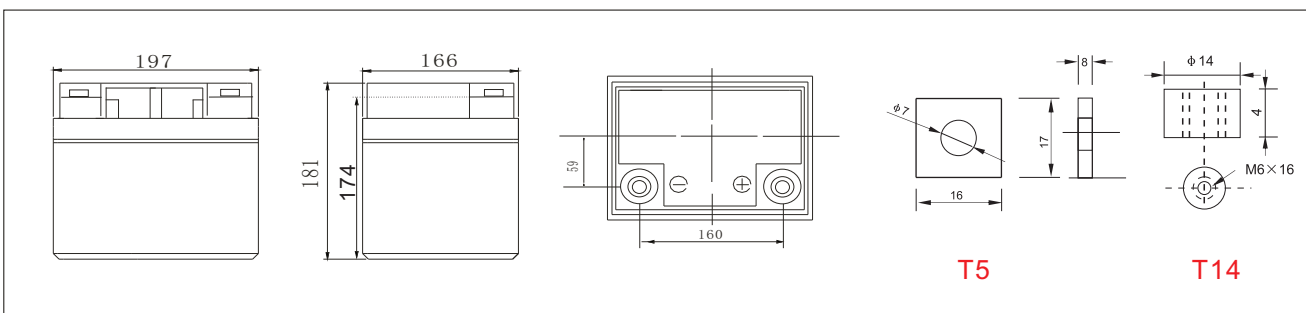

Constant Current(Amp) and Constant Power (Watt) Discharge Table at 25°C (77°F)													
Time		5min	10min	15min	30min	1hr	2hr	3hr	4hr	5hr	8hr	10hr	20hr
9.60V	A	128.00	84.00	68.00	45.60	24.00	14.00	10.30	8.00	6.60	4.68	4.20	2.27
	W	1322.00	901.00	730.00	490.00	259.00	154.00	114.00	90.00	75.00	54.00	49.00	26.40
10.20V	A	124.00	76.00	64.00	43.60	22.60	13.40	10.00	7.80	6.50	4.56	4.12	2.20
	W	1325.00	850.00	717.00	489.00	255.00	154.00	116.00	91.00	76.00	53.00	48.00	25.80
10.50V	A	120.00	68.00	56.00	40.80	21.80	13.00	9.80	7.70	6.40	4.52	4.04	2.20
	W	1311.00	775.00	640.00	470.00	253.00	151.00	114.00	90.00	75.00	53.00	48.00	26.00
10.80V	A	116.00	64.00	52.00	37.60	21.10	12.70	9.50	7.60	6.20	4.40	4.00	2.16
	W	1298.00	740.00	600.00	436.00	246.00	149.00	112.00	89.00	74.00	52.00	48.00	25.70
11.10V	A	112.00	60.00	48.00	33.60	20.40	12.40	9.20	7.40	6.10	4.28	3.80	2.04
	W	1268.00	697.00	560.00	393.00	240.00	147.00	109.00	88.00	73.00	51.00	45.90	24.70



Discharge characteristic Curve

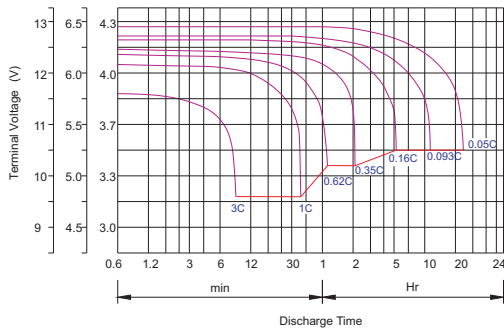

Cycle service life in relation to depth of discharge

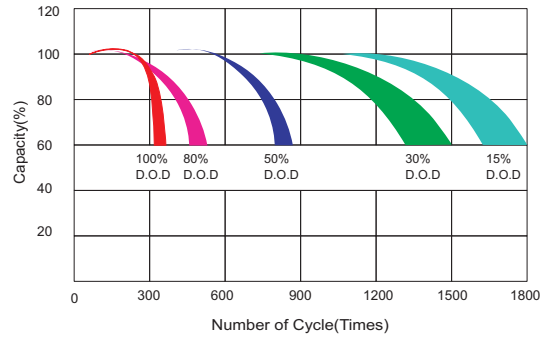

Relationship between charging voltage and temperature

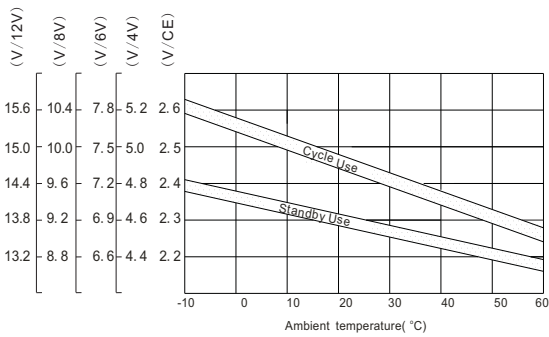

Constant voltage charging characteristic (0.25CA, at 25°C)

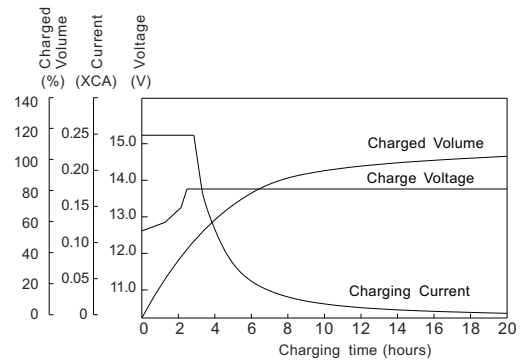

Life characteristics of standby use

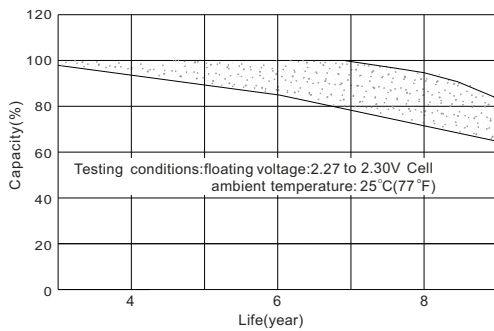

Self-discharge characteristic

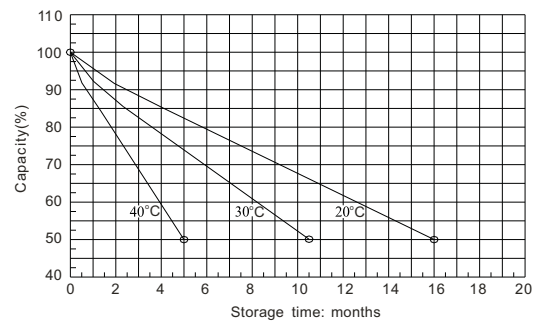

Temperature effects on float life

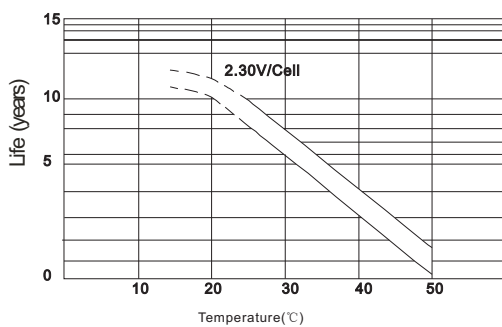

Charge characteristic Curve for standby use

