

# 6GFMJ-100

## GEL Battery (12V100Ah)

### Features

- GEL battery adopts high-tin alloy grid which enhance corrosion resistance of plates and lengthen the service life.
- High-tight assembly technics and supporting equipments greatly improve charge acceptance and high current discharge performance.
- Precision vacuum acid filling method, advanced and environmentally friendly container formation technics ensures battery consistency effectively, over 50% of the cyclic performance of the lead-acid battery.
- Post seal structures adopt patented technology of seal structure and high-temperature curing epoxy adhesive, which ensure battery safety and reliability.

### Dimensions

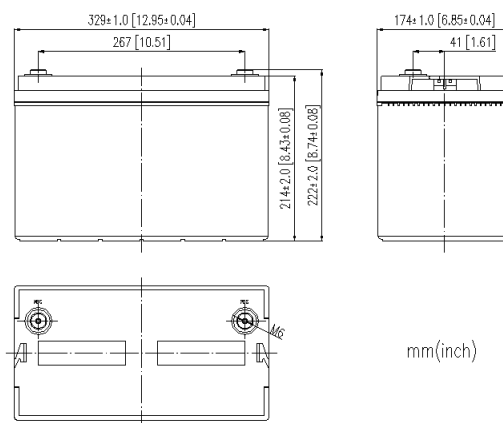

### Product Structure and Working Principle

- Cathode absorption sealed maintenance-free GEL battery consists of ABS case, grid type plate, AGM separator and electrolyte.

### Application Fields

- Solar photovoltaic energy field, electric wheelchairs field, medical equipment field, washing machines field and so on.

### Specifications

Type	GEL Battery
Nominal Voltage	12V
Rated Capacity	100Ah(10hr, 10.8V, 25°C)
Approx Dimensions(mm)(Length×Width×Height)	329(mm)×174(mm)×222(mm)
Design Life Time	≥10 Years
Approx Weight(kg)	31.0kg
Applicable Temperature	-25°C~50°C
Optimum Temperature	20°C~25°C
Self-discharge	Self-discharge rate < 0.1% per day(20°C)
Materials for Battery Containers and Covers	ABS
Screw Hole Size(mm)	M6
Reference Installation Dimension	According to Clients' Requirements

Follow us



# TECHNICAL GRAPHS

### Discharge Characteristics Curve at 25°C

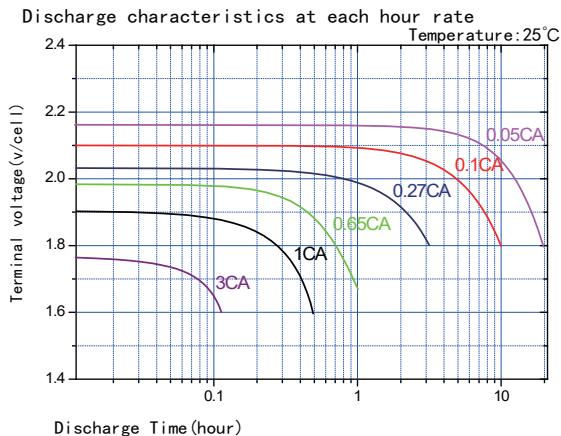

### Charging cycle Characteristics Curve

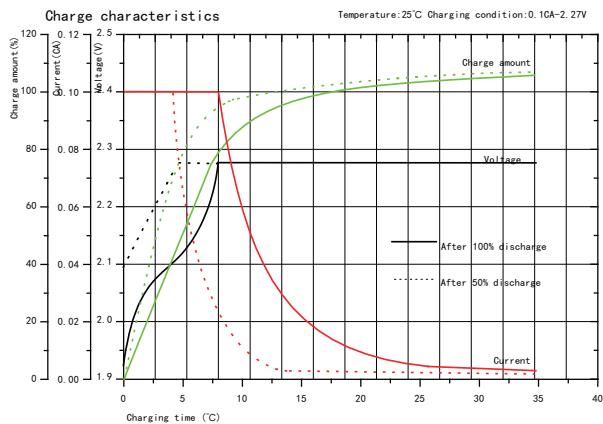

### Temperature Vs. Capacity

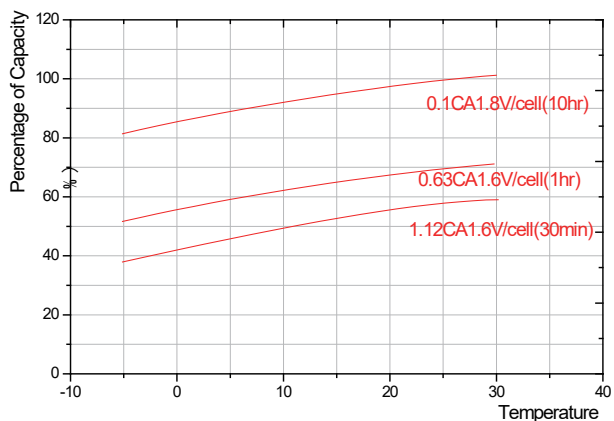

### Cycle Life Vs Depth Of Discharge

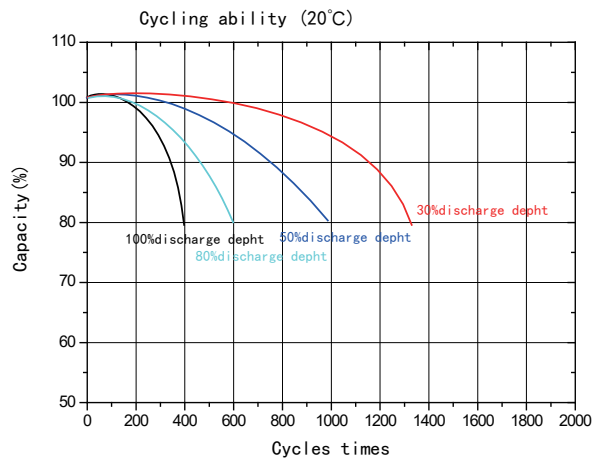

### Discharge Current Vs End-voltage

Discharge Rate	0.10C	0.17C	0.25C	0.6C	3C
End-Voltage(V)	10.80	10.50	10.20	9.60	9.60

### Charging Ways

Type	Voltage(V)	Temperature compensation coefficient	Charge Current(A)
Cycle Use	14.40±0.18	-4mV/°C	0.1C~0.25C <sub>10</sub>
Float Charge Use	13.65±0.12	-3mV/°C	



Follow us

