

stored energy solutions for a demanding world



Model: **60PzV400**

Ares series

Ares range battery adopts traditional tubular gel technology, adopts patent gel electrolyte. The products are used as standby power for communication, power, military and broadcast and television system. They possess precise ABS heat seal technology between container and lid and patented post seal structure. Provide better deep cycle performance versus AGM. The design float life is 18+ years.



Specifications

Battery Model	60PzV400
Nominal Voltage	2V
Rated Capacity	400Ah (10hour rate) to 1.80V/cell @25°C(77°F)
Typical Weight	35kg
Internal Resistance	Approx 0.512mΩ
Operating Temperature Range	Operation (maximum): -40°C to 55°C(-40°F to 131°F)
	Operation (recommended): 15°C to 25°C(59°F to 77°F)
	Storage: -20°C to 40°C(-4°F to 104°F)
Float Voltage	2.23V/cell@25°C(77°F)
Charge Current	40A(Recommendation) 100A(Maxmum)
Equalize and Cycle Service	2.35V~2.40V/cell@25°C(77°F)
Self Discharge	The residual capacity is above 94% after 90 days storage(25°C/77°F)
Terminal	M8 Female Large Size Copper Post
Terminal Hardware Torque	15 ± 1.0Nm
Container Material	ABS (V0 optional)

Discharge Data with Constant Current Units : Amperes (25°C, 77°F)

End voltage	15min	30min	1h	2h	3h	4h	5h	6h	8h	10h	16h	24h	48h	100h
1.60V	450	359	246	153	110	87	74.8	65.8	53.0	43.5	28.1	19.5	10.7	6.0
1.65V	434	347	240	149	108	86	74.0	65.0	52.6	43.3	27.9	19.5	10.6	5.9
1.70V	409	333	233	146	107	85	73.0	64.0	52.0	43.1	27.8	19.3	10.5	5.8
1.75V	387	320	226	142	104	84	71.8	62.7	51.0	42.4	27.4	18.9	10.4	5.7
1.80V	342	293	215	137	102	82	70.1	61.1	49.8	40.2	26.5	18.5	10.2	5.5
1.85V	288	247	200	130	99	79	67.9	59.0	48.4	39.6	26.2	17.9	9.7	5.3
1.90V	217	210	160	113	88	74	63.1	54.5	43.9	36.5	23.5	16.4	9.1	4.9

Discharge Data with Constant Power Units: Watts per cell (25°C, 77°F)

End voltage	15min	30min	1h	2h	3h	4h	5h	6h	8h	10h	16h	24h
1.60V	899	712	545	299	227	181	151.9	131.9	109.2	91.7	59.2	40.1
1.65V	856	674	507	297	226	180	150.9	130.6	108.4	91.1	58.8	39.9
1.70V	817	644	475	293	223	177	148.8	128.7	106.9	89.8	57.9	39.3
1.75V	774	618	447	285	217	170	143.5	126.4	105.2	88.2	56.9	38.7
1.80V	724	593	422	275	211	166	136.9	120.0	100.2	83.6	54.0	36.7
1.85V	677	570	392	264	210	158	133.3	115.0	95.2	80.2	51.8	35.2
1.90V	633	520	349	240	194	151	130.0	104.3	86.3	72.7	46.9	31.9

Dimensions-mm [inch]

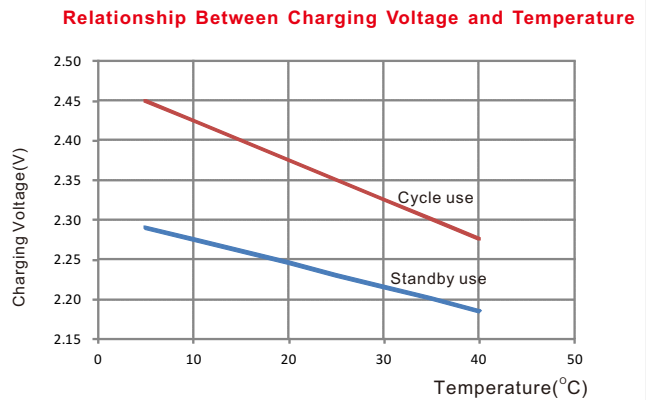
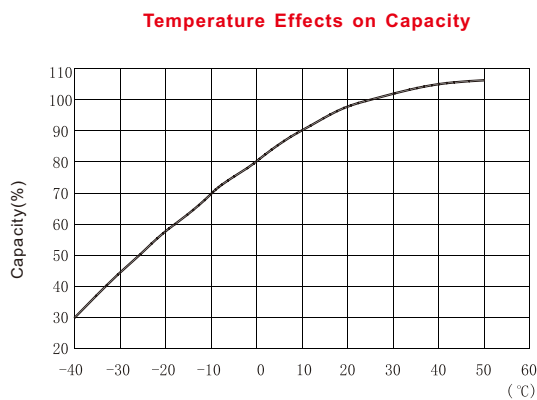
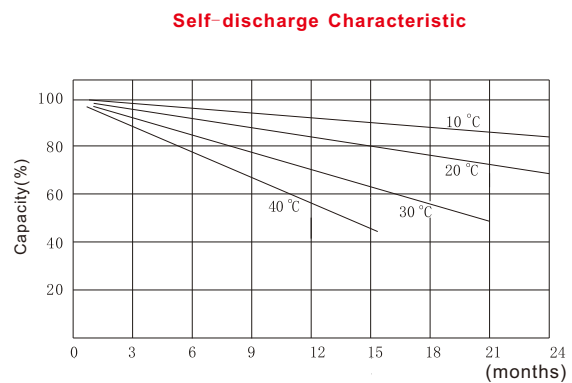
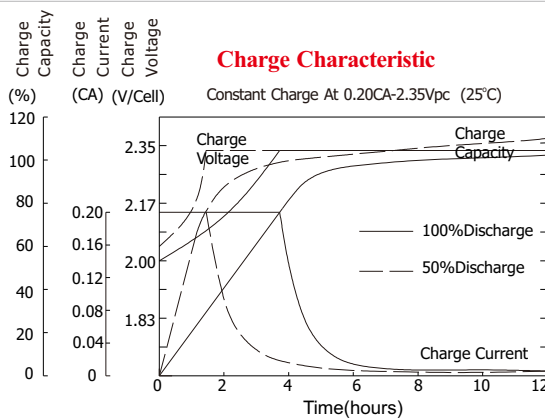
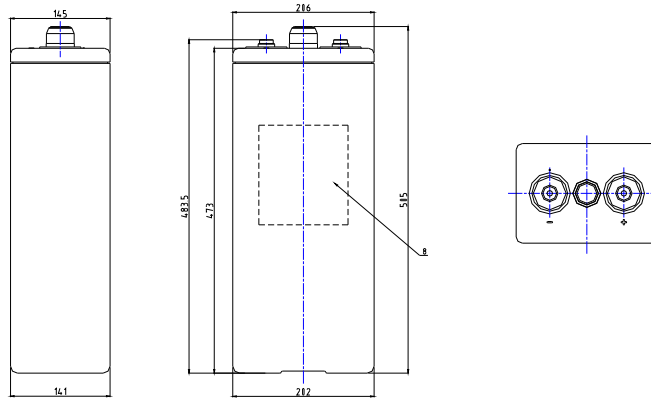

NARADA POWER SOURCE CO.,LTD.
 9F, Building A, No. 50 Zijinghua Road, Hangzhou, China
 Tel:+86-571-28827013 Fax:+86-571-28828290
 Website:www.naradabattery.com E-mail: intl@narada.biz

NARADA ASIA PACIFIC PTE.LTD.
 65 Ubi Crescent #07-05 HOLA centre, Singapore
 Tel: +65-6848 1191 Fax: +65-6749 3498
 E-mail: sales@narada.com.sg

NARADA EUROPE (UK) LIMITED
 Spectrum House, Dunstable Road, Redbourn,
 St. Albans, Herts AL3 7PR
 Tel: +44 (0)845 371 7095 Fax:+44 (0)845 612 2031
 E-mail: sales@naradaeurope.com

