

SAJ Series

SAJ-100 12V100Ah



SAJ series battery uses AGM and gel mixed technology. It has good cycle life and large current discharge performance. It is a cost effective product and can be widely used in different photovoltaic, lighting, power supply and control systems.



Benefits

- Long life according to EUROBAT Classification
- Special AGM separator, adding gel electrolyte, long shallow cycle life.
- Maximum charge efficiency
- High gas recombination efficiency
- Low self-discharge rate
- Horizontal or Vertical installation
- Easy installation and handling

Applications

- Solar (Wind) energy system
- Solar communication/station
- Mobile storage system

Drawing

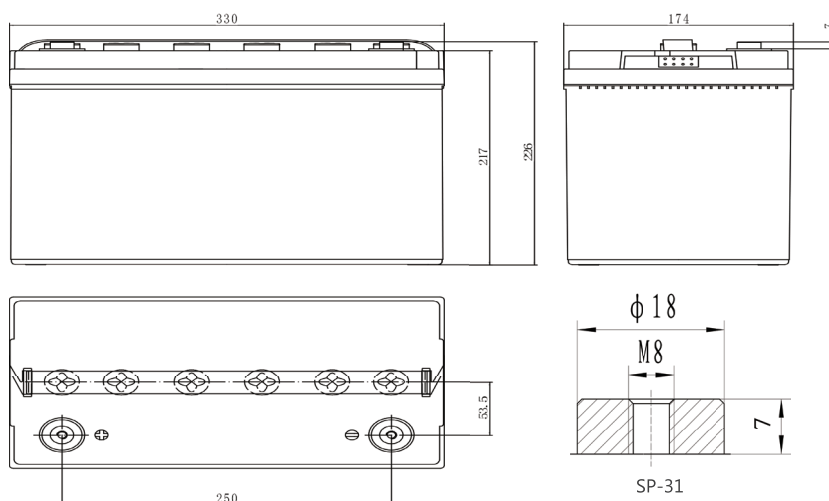

Standards

- IEC 60896-21/22
- DIN 43539-T5
- EUROBAT guide

Specifications

Battery Model	SAJ12-100			
Design Life (years, 25°C)	10			
Capacity (Ah, 25°C)	20HR (5.0A, 1.80V)	5HR (9.3A, 1.80V)	3HR (16.85A, 1.80V)	1HR (52.50A, 1.75V)
	100	93.0	84.25	52.50
Dimensions (mm)	Length	Width	Height	Total Height
	330	174	217	226
Approx. Weight (kg)	29.8			
Reference Internal Resistance (mΩ)	4.2 (fully charged @ 25°C)			
Maximum Discharge Current (A/5 Sec.)	1000			
Self-Discharge (25°C)	≤ 1.5% per months			
Charge Voltage (V/cell, 25°C)	Cycle use		Float use	
	2.40(-3.5mV/°C/cell), max charge current: 20A		2.27(-3.5mV/°C/cell)	
Short Circuit Current (A)	2800			

Discharge Data

Constant Current Discharge Data (25°C, A)									
End Voltage (V/cell)	h								
	1	3	5	10	20	50	100	120	240
1.70	55.70	25.80	17.70	9.750	5.280	2.220	1.160	0.980	0.520
1.75	54.20	25.30	17.35	9.550	5.150	2.180	1.140	0.966	0.510
1.80	52.50	24.50	16.85	9.300	5.000	2.130	1.120	0.950	0.500
1.85	50.50	23.60	16.25	9.050	4.900	2.070	1.090	0.926	0.490
1.90	48.00	22.50	15.55	8.700	4.750	2.000	1.060	0.900	0.480

Constant Power Discharge Data (25°C, W/cell)									
End Voltage (V/cell)	h								
	1	3	5	10	20	50	100	120	240
1.70	100.0	45.10	32.00	18.10	9.800	4.100	2.350	2.020	1.030
1.75	97.00	44.88	31.40	17.70	9.600	3.920	2.270	1.950	1.010
1.80	94.00	44.15	30.50	17.20	9.500	3.890	2.190	1.890	0.980
1.85	91.00	43.75	29.50	16.50	9.300	3.790	2.070	1.810	0.920
1.90	88.50	42.97	29.00	16.30	9.100	3.720	2.000	1.730	0.890

Performance Curve

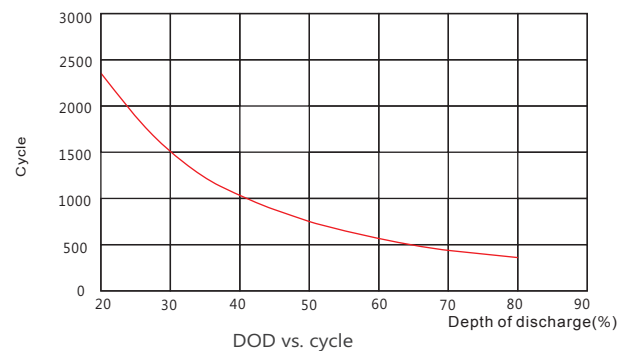
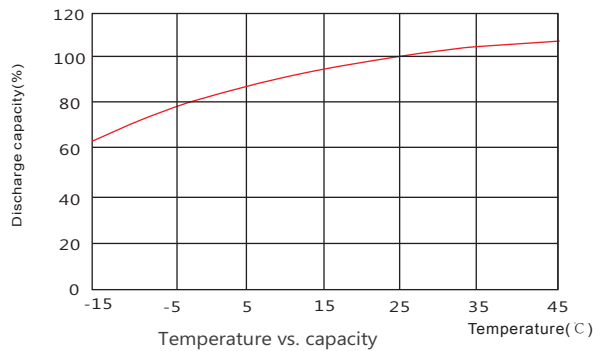
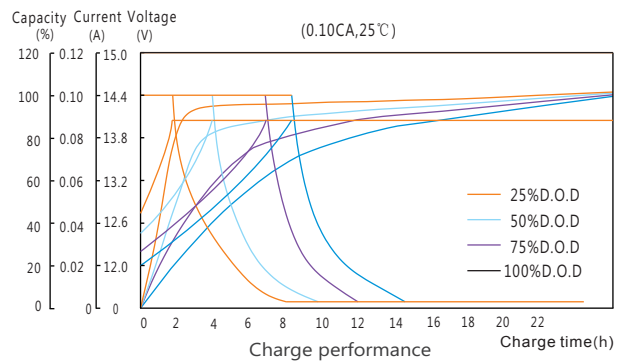
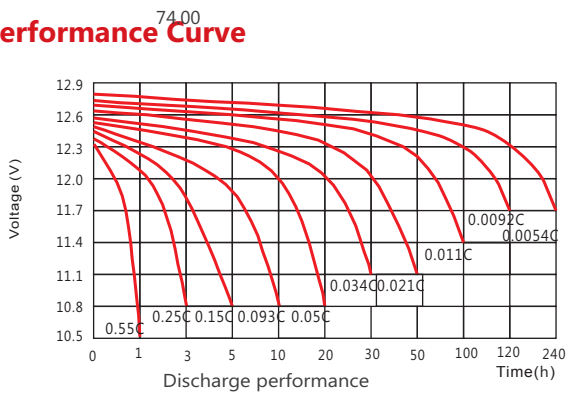

Sacred Sun Power Sources Co., Ltd.

No.1 Shengyang Road Qufu City, PRC
sales@sacredsun.cn

Sacred Sun Asia Pacific

No. 15, Yishun Industrial Street 1,
#01-17, WIN5, Singapore 768091
sales.asia@sacredsun.cn

Sacred Sun Europe SPRL

Schoenstraat 96-9140 Temse, Belgium
sales.eu@sacredsun.cn

Sacred Sun MEA FZE

S10122A1019 Jebel Ali, Dubai,
United Arab Emirates
sales.mea@sacredsun.cn

