



## UN250-12X (12V250Ah/10hr)

The rechargeable batteries are lead-lead dioxide systems. The dilute sulfuric acid electrolyte is absorbed by separators and thus immobilized.

Should the battery be accidentally overcharged producing hydrogen and oxygen, Special one-way valves allow the gases to escape thus avoiding excessive pressure build-up. Otherwise, the battery is completely sealed and is, therefore, maintenance-free, leak proof and usable in any position.

### Battery Construction

Component	Positive plate	Negative plate	Container	Cover	Safety valve	Terminal	Separator	Electrolyte
Raw material	Lead dioxide	Lead	ABS	ABS	Rubber	Copper	Fiberglass	Sulfuric acid

### General Feature

- Absorbent Glass Mat(AGM) technology for efficient gas recombination of up to 99% and freedom from electrolyte maintenance or water adding.
- Not restricted for air transport-complies with IATA/ICAO Special Provision A67.
- UL-recognized component.
- Can be mounted in any orientation.
- Computer designed lead, calcium tin alloy grid for high power density.
- Long service life, float or cyclic applications.
- Maintenance-free operation.
- Low self discharge.

### Performance Characteristics

Capacity 77°F(25°C)	20 hour rate (13A、10.8V)	260Ah
	10 hour rate (25A、10.5V)	250Ah
	5 hour rate (43A、10.5V)	213Ah
	1 hour rate (159A、9.6V)	159Ah
Internal Resistance	Full charged Battery77°F(25°C): 4mΩ	
Capacity affected by Temperature (20 hour rate)	104° F(40°C)	102%
	77° F(25°C)	100%
	32° F(10°C)	85%
	5° F(-15°C)	65%
Self-Discharge 68°F(20°C)	Capacity after 3 month storage	90%
	Capacity after 6 month storage	80%
	Capacity after 12month storage	60%
Max. discharge current77°F(25°C): 1250A(5S)		
Charge (Constant Voltage)	Float: 13.6~13.8 V/77° F/(25°C)	
	Cycle:14.4~14.7V/77°F/(25°C) Max. Current: 62.5A	

### SPECIFICATION

Nominal voltage ..... 12V  
 Number of cell ..... 6  
 Length(mm/inch) ..... 520/20.5  
 Width(mm/inch) ..... 268/10.6  
 Height(mm/inch) ..... 220/8.66  
 Total Height(mm/inch) ..... 224/8.82  
 Approx. Weight(kg/lbs) ..... 69.2/152.5

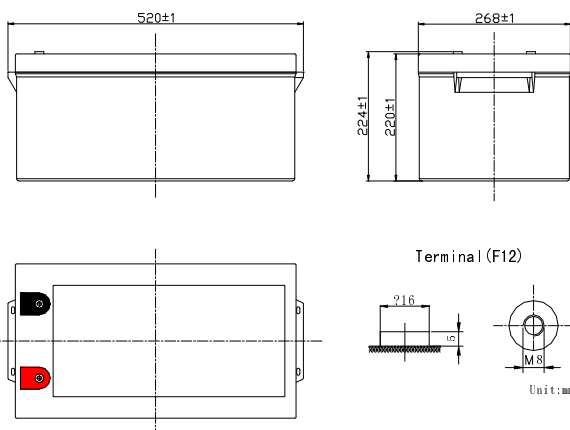

Discharge Constant Current (Amperes at 77° F 25 °C)

End Point Volts/Cell	5min	10min	15min	30min	1h	3h	5h	10h	20h
1.60V		577	401	265	159	69.0	44.5	25.3	13.3
1.65V		552	382	259	156	68.0	44.0	25.2	13.2
1.70V		527	363	251	153	67.0	43.5	25.1	13.2
1.75V		502	343	243	150	65.8	43.0	25.0	13.1
1.80V		473	318	234	145	64.3	42.3	24.8	13.0

Discharge Constant Power (watts at 77° F 25 °C)

End Point Volts/Cell	5min	10min	15min	30min	45min	1h	2h	3h	5h
1.60V		981	738	511	394	322	187	143	94.6
1.65V		966	733	508	392	320	186	142	94.3
1.70V		948	726	504	389	317	184	141	94.0
1.75V		913	718	501	387	314	183	140	93.7
1.80V		875	707	496	384	310	181	138	93.3

(Note)The above characteristics data are average values obtained Within three charge/discharge cycles not the minimum values.

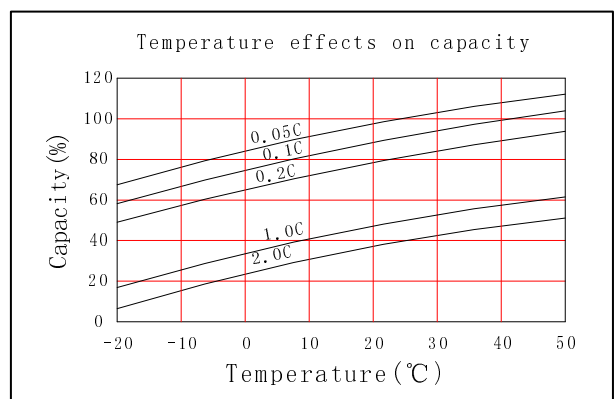
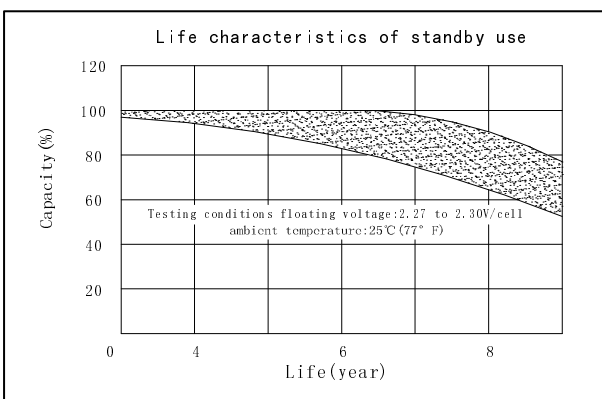
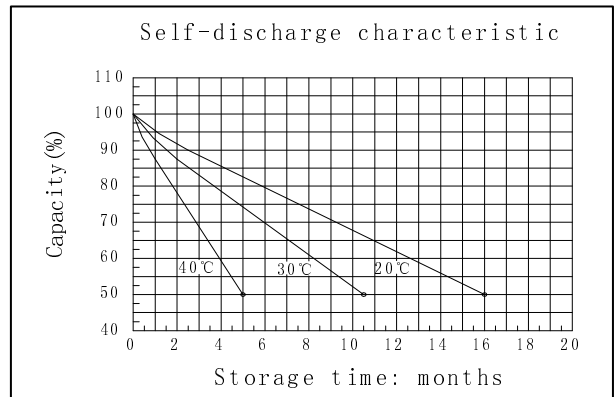
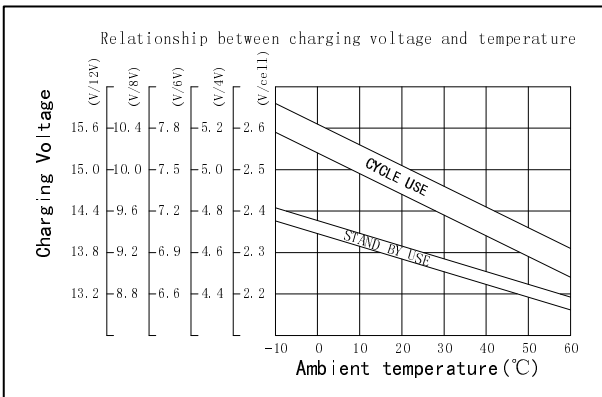
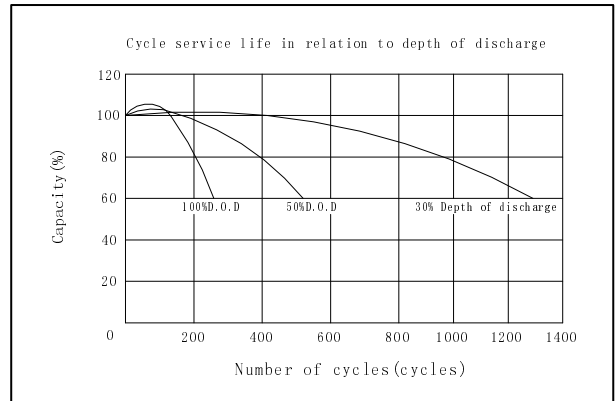
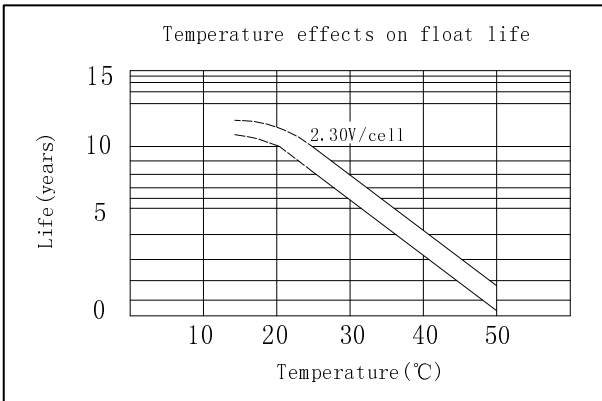
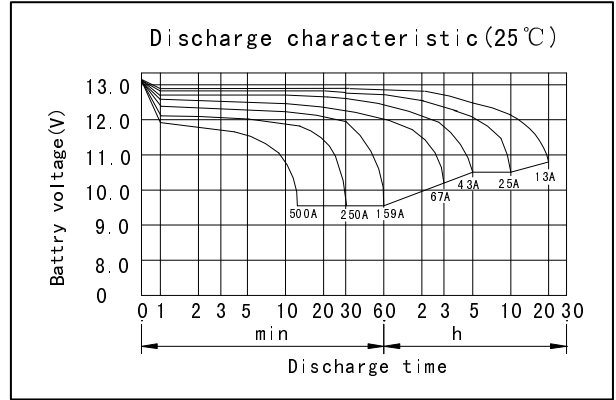
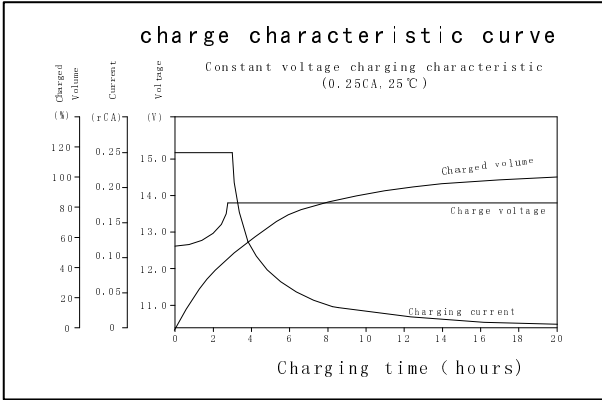

**DONGGUAN OREMA POWER CO., LTD**  
 Add: Daping Industrial Area, Tangxia Town, 523722 Dongguan China  
 TEL: +86-769- 8201 6663 +86-769- 8786 5131  
 FAX: +86-769- 87865135

MH29838  
D4M20412-5881-E-18

[www.oremabattery.com](http://www.oremabattery.com)