



PR1232 is a general purpose battery with 5 years life in standby service, or more than 260 cycles at 100% D.O.D by cyclic use. As with all PROSTAR batteries, all PR models are rechargeable, highly efficient, leak proof and maintenance free.

Specification

Cells Per Unit	6
Voltage Per Unit	12
Capacity	3.2Ah@20hr-rate to 1.75V per cell @25?
Weight	Approx.1.3Kg
Max. Discharge Current	32A(5 sec)
Internal Resistance A	Approx. 40m?
Operating Temperature Range	Discharge: -20? ~60? Charge: 0? ~50? Storage: -20? ~60?
Normal Operating Temperature Range	25? ±5?
Float charging Voltage	13.6 to 13.8VDC/unit Average at 25?
Recommended Maximum Charging Current Limit	0.96A
Equalization and Cycle Service	14.4 to 15.0VDC/unit Average at 25?
Self Discharge	PROSTAR batteries can be stored for more than 6 months at 25? . Please charge batteries before using. For higher temperature, the time interval will be shorter.
Terminal	Faston Tab 187(F1)
Container Material	A.B.S. (UL94-HB) Flammability resistance of UL94-V2 can be available upon request



Dimensions

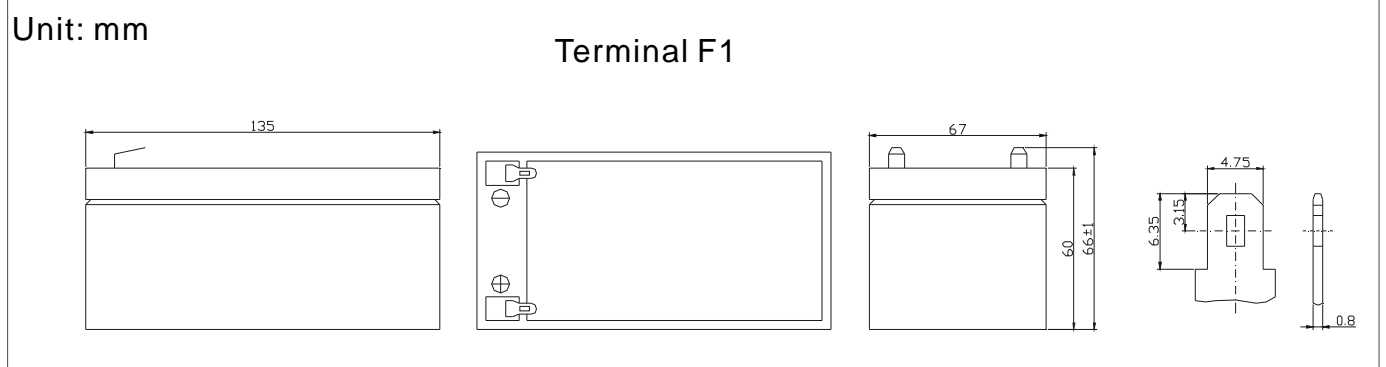

Constant Current Discharge Characteristics Unit: A(25?)

F.V/Time	5M N	10M N	15M N	30M N	1HR	2HR	3HR	4HR	5HR	8HR	10HR	20HR
9.60V	13 3	8 88	6 83	3 75	2 22	1 33	0 82	0 67	0 54	0 40	0 31	0 18
10.0V	12 4	8 28	6 42	3 70	2 21	1 32	0 82	0 67	0 54	0 40	0 31	0 17
10.2V	11 8	8 03	6 27	3 67	2 19	1 32	0 81	0 67	0 53	0 40	0 31	0 17
10.5V	10 6	7 51	5 94	3 58	2 16	1 30	0 81	0 66	0 53	0 40	0 30	0 16
10.8V	9 49	7 00	5 61	3 50	2 13	1 28	0 80	0 66	0 53	0 39	0 30	0 15
11.1V	8 36	6 49	5 29	3 41	2 10	1 26	0 80	0 66	0 52	0 39	0 29	0 15

Constant Power Discharge Characteristics Unit: W(25?)

F.V/Time	5M N	10M N	15M N	30M N	1HR	2HR	3HR	4HR	5HR	8HR	10HR	20HR
9.60V	25 6	16 6	13 5	7 51	4 44	2 66	1 64	1 34	1 27	0 80	0 62	0 35
10.0V	24 0	16 0	12 8	7 39	4 43	2 64	1 63	1 33	1 26	0 80	0 62	0 34
10.2V	23 5	15 5	12 5	7 34	4 42	2 64	1 63	1 33	1 26	0 79	0 61	0 33
10.5V	21 3	14 9	11 9	7 16	4 34	2 60	1 62	1 32	1 25	0 79	0 60	0 32
10.8V	19 0	13 9	11 2	6 99	4 27	2 56	1 61	1 32	1 25	0 78	0 60	0 31
11.1V	16 4	13 0	10 6	6 82	4 20	2 52	1 59	1 31	1 25	0 78	0 59	0 30

All mentioned values are average values

Temperature effects curve

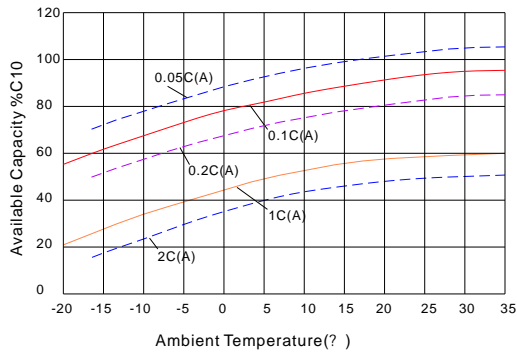

Storage characteristic

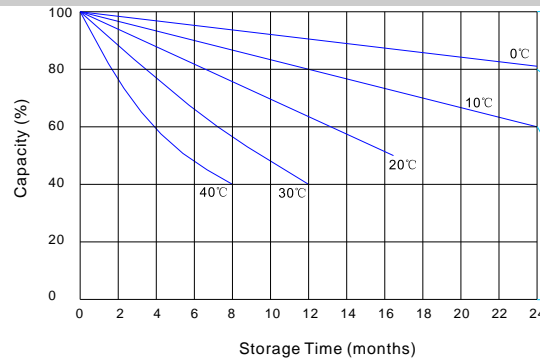

Supplementary charge required (Carry out supplementary y charge before use if 100% capacity is requires)

Supplementary charge required before use. This supplementary y charge will help to recover the capacity and should be made as early as possible.

Supplementary charge may often fail to recover the capacity. The batter y should never be left standing till this state is reached

Supplementary y charge and storage guidelines

Life characteristics of cyclic use

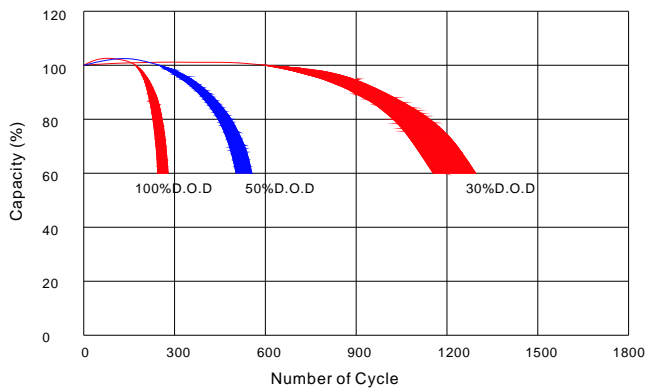

Effect of temperature on long term float life

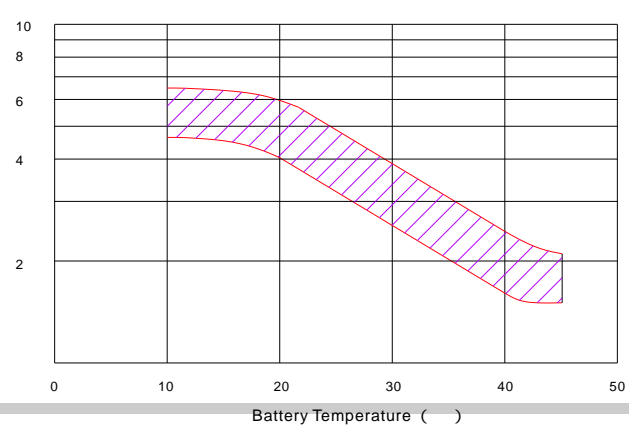

Charge characteristic Curve for standby use

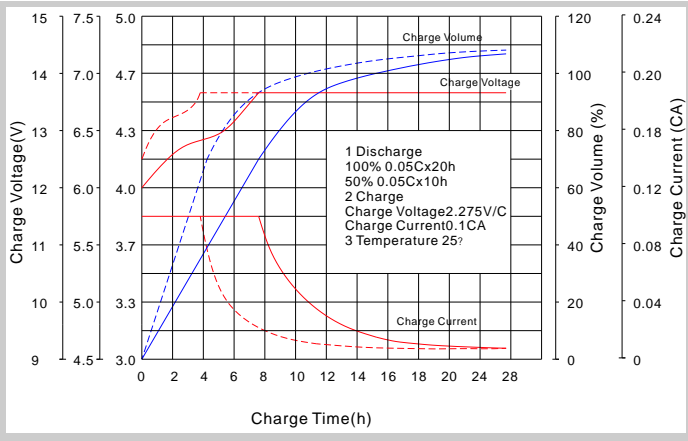

Discharge characteristic curve

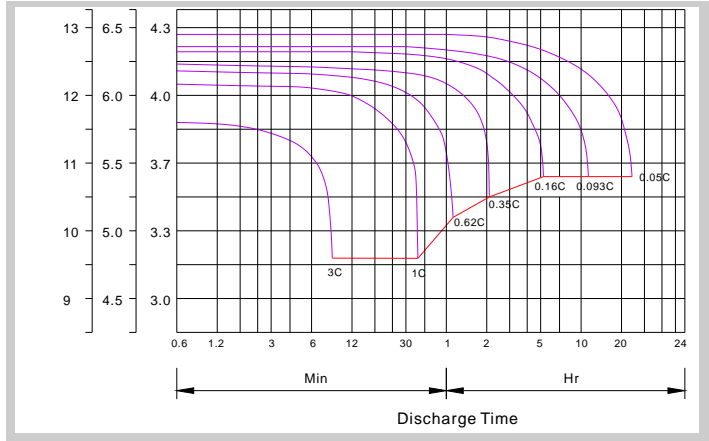

Charging Procedures

Application	Charge Voltage (V)			Max.Charge Current
	Temperature	Set point	Allowable range	
Cycle Use	25°	14.7	14.4~15.0	0.3C
Standby	25°	13.7	13.6~13.8	0.3C

Discharge Current VS. Discharge Voltage

Final Discharge Voltage V/cell	1.75V	1.70V	1.60V
Discharge Current (A)	(A)<0.20C	0.20C<(A)<1.0C	(A)>1.0C

Charge the batteries at least once every six months, if they are stored at 25° .

Charging Method:

Constant Voltage	14.4~15.0V,24h,Max. Current 0.3CA
Constant Current	0.1CAx5h
Fast	0.3CAx1.7h

Charging Procedures(6V series)

Application	Charge Voltage (V)			Max. Charge Current
	Temperature	Set point	Allowable range	
Cycle Us	25°	7.35	7.25~7.45	0.3C
Standby	25°	6.85	6.8~6.9	0.3C