



PR12-90D is AGM Deep cycle battery with 10 years floating design life, specially designed for frequent cyclic discharge usage. By using strong grid and specific paste plate, it makes battery have 30% more cyclic life time than standby series. It is applicable for solar energy system, golf cart, electric wheelchair, etc..

## Specification

Cells Per Unit	6
Voltage Per Unit	12
Capacity	90Ah@10hr-rate to 1.75V per cell @25C °
Weight	Approx. 28.5 Kg
Max. Discharge Current	900 A (5 sec)
Internal Resistance	Approx. 5.2 m
Operating Temperature Range	Discharge: -20 °C~60°C Charge: 0C~50C ° Storage: -20C~60C °
Normal Operating Temperature Range	25C ± 5C
Float charging Voltage	13.6 to 13.8 VDC/unit Average at 25C °
Recommended Maximum Charging Current Limit	27A
Equalization and Cycle Service	14.6 to 14.8 VDC/unit Average at 25C °
Self Discharge	PROSTAR batteries can be stored for more than 6 months at 25C. Self-discharge ratio less than 3% per month at 25C. Please charge batteries before using.
Terminal	Terminal F15/F12
Container Material	A.B.S. (UL94-HB) , Flammability resistance of UL94-V1 can be available upon request.



## Dimensions

Unit: mm Dimension: 306.5(L) × 168.5(W) × 235 (H)

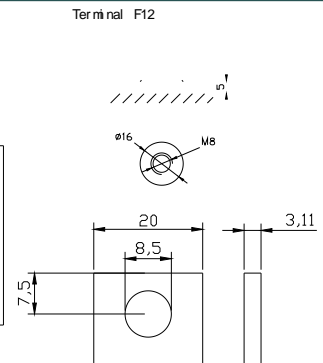
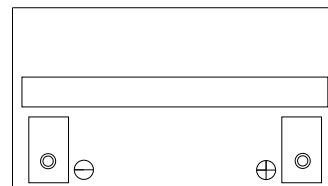
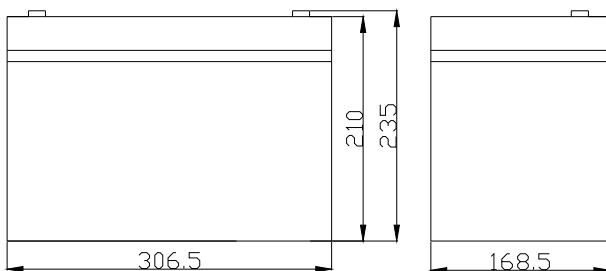

### Constant Current Discharge Characteristics: A (25C) °

F.V/Time	5MIN	10MIN	15MIN	30MIN	1HR	2HR	3HR	4HR	5HR	8HR	10HR	20HR
9.60V	310.2	222.3	161.7	99.36	56.16	31.85	22.55	18.66	14.69	10.73	9.07	4.80
10.0V	301.9	211.5	158.4	97.72	55.90	31.60	22.46	18.58	14.60	10.65	8.99	4.71
10.2V	284.5	204.0	155.9	96.85	55.38	31.36	22.29	18.49	14.52	10.56	8.90	4.62
10.5V	255.5	188.3	148.5	94.44	54.86	31.11	22.20	18.32	14.34	10.47	8.81	4.54
10.8V	230.6	171.7	136.9	90.29	53.57	30.54	21.60	17.88	14.08	10.30	8.73	4.45
11.1V	200.7	153.4	122.8	84.59	50.89	30.04	20.65	17.02	13.48	9.860	8.46	4.19

### Constant Power Discharge Characteristics: W (25C) °

F.V/Time	5MIN	10MIN	15MIN	30MIN	1HR	2HR	3HR	4HR	5HR	8HR	10HR	20HR
9.60V	3233	2364	1740	1121	642.3	376.7	260.2	215.7	170.0	124.5	102.0	53.90
10.0V	3167	2258	1704	1107	639.2	375.3	259.7	215.1	169.0	124.0	101.0	53.37
10.2V	2989	2183	1681	1094	634.5	371.8	258.2	214.1	168.5	123.0	100.5	52.85
10.5V	2692	2017	1603	1069	628.3	368.4	256.6	212.5	166.9	121.9	99.42	52.33
10.8V	2421	1831	1473	1021	612.7	363.0	250.4	206.8	164.3	119.3	98.38	51.80
11.1V	2090	1626	1315	956.4	580.6	346.2	237.9	197.0	156.0	115.1	95.24	49.71

All mentioned values are average values.

### Life characteristics of cyclic use

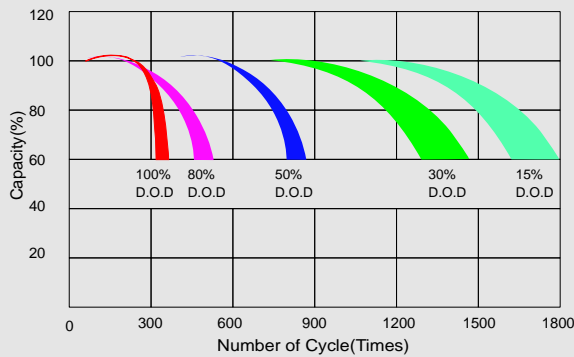

### Storage characteristic

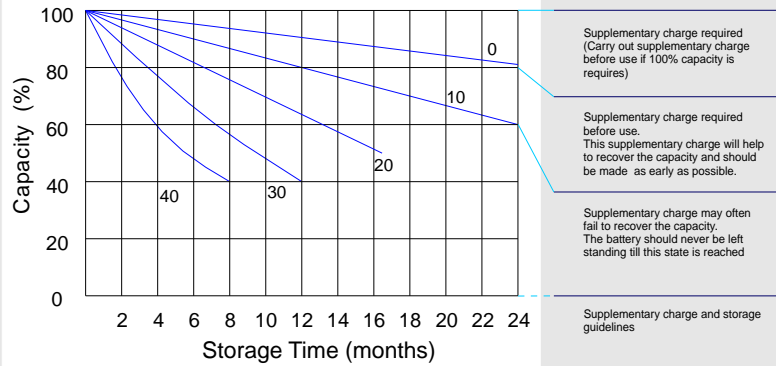

### Charge characteristic Curve for standby use

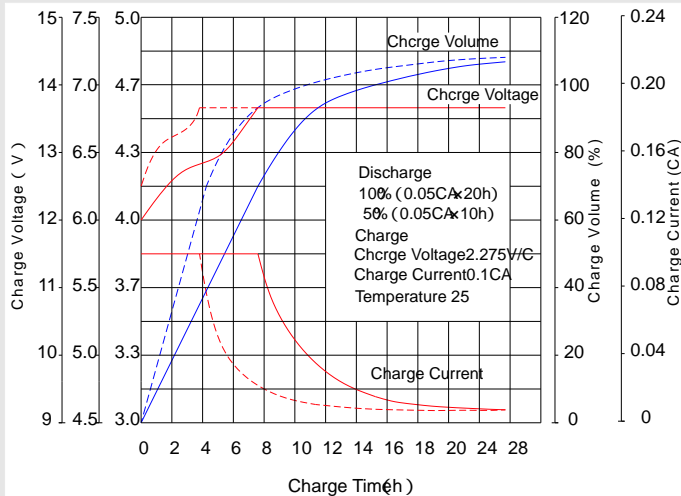

### Discharge characteristic Curve

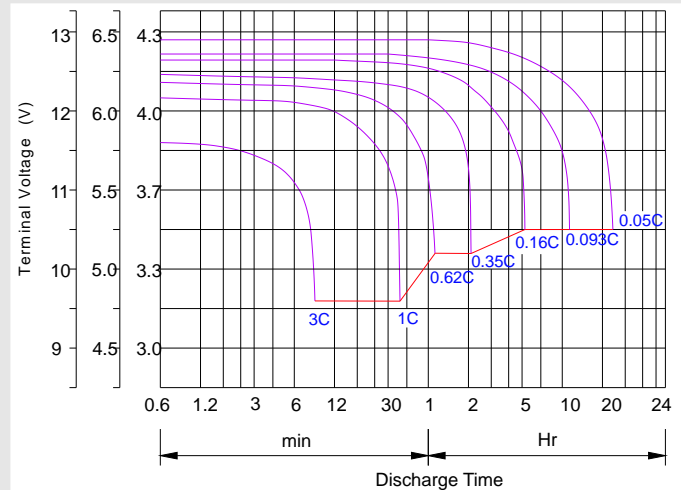

### Capacity Factors With Different Temperature

Battery Type		-20	-10	0	5	10	20	25	30	40	45
GEL Battery	6V&12V	50%	70%	83%	85%	90%	98%	100%	102%	104%	105%
	2V	60%	75%	85%	88%	92%	99%	100%	103%	105%	106%
AGM Battery	6V&12V	46%	66%	76%	83%	90%	98%	100%	103%	107%	109%
	2V	55%	70%	80%	85%	92%	99%	100%	104%	108%	110%

### Discharge Current VS. Discharge Voltage

Final Discharge Voltage V/cell	1.75V	1.70V	1.60V
Discharge Current (A)	(A) 0.2C	0.2C < (A) < 1.0C	(A) 1.0C

### Maintenance & Cautions

#### Cycle service

- Avoid battery over discharge, especially battery series connection use.
- Charged with recommend voltage, ensure battery can be full recharged.
- In general, recharge capacity should be 1.1-1.15 times discharge capacity.
- Effect of temperature on cycle charge voltage: -4mV//Cell.
- There are a number of factors that will affect the length of cyclic service.
- The most significant are depth of discharge, ambient temperature, discharge rate, and the manner in which the battery is recharged.
- Generally speaking, the most important factors is depth of discharge.

**Charge the batteries at least once every six months, if they are stored at 25°C**

#### Charging Method:

Constant Voltage	-0.2Cx2h+2.4-2.45V/Cellx24h,Max. Current 0.3CA
Constant Current	-0.2Cx2h+0.1CAx12h
Fast	-0.2Cx2h+0.3CAx4.0h