

# LHT SERIES-High TEMPERATURE

## LHT2-500(2V500AH)



### Applications

- ◆ Tele-communication central station
- ◆ Power system communication, military communication, etc.
- ◆ Network communication including: data transmission, television signal transmission, etc.
- ◆ Uninterruptable Power System (UPS for Telecom)

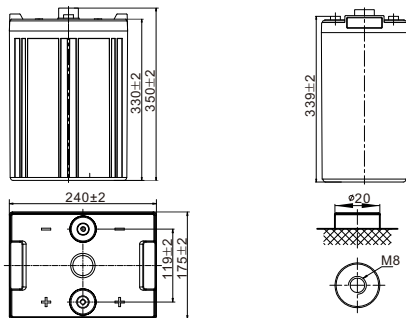

### Specification

Nominal Voltage	2V	
Nominal Capacity(10HR)	500Ah	
Dimension	Length	240mm (9.45 in.)
	Width	175mm (6.89 in.)
	Container Height	327.5mm (12.89 in.)
	Total Height (with Terminal)	347.5mm (13.68 in.)
Approx Weight	34.6 Kg (76.3 lbs)	
Terminal	T 11(M8,Torque11~14.7N·m)	
Container Material	ABS(High Temperature Resistant Material)	
Rated Capacity( 35°C)	C20(26.5A, 1.80V/cell)	530.0 Ah
	C10(50.0A, 1.80V/cell)	500.0 Ah
	C5(88.8A, 1.75V/cell)	444.0Ah
	C3(132.5A, 1.75V/cell)	397.5 Ah
	C1(307.5A, 1.67V/cell)	307.5 Ah
Max. Discharge Current	3000A (5s)	
Internal Resistance	Approx 0.60mΩ	
Operating Temp.Range	The battery could use at -40°C~+65°C and extreme temperature can be up to 80°C.	
Cycle Use ( 35°C)	Charging Current	≤125A
	Charging Voltage	2.35V~2.40V
Standby Use ( 35°C)	Charging Current	≤125A
	Charging Voltage	2.25V
	Temp. Coefficient	-3mV/cell/°C
Capacity affected by Temperature	40°C (104°F)	103%
	35°C (95°F)	100%
	0°C (32°F)	79%
Monthly Self Discharge	≤3% per month at 25°C	

### Constant Current Discharge (Amperes) at 35 °C (95°F)

F. V/Time	5min	10min	15min	20min	30min	45min	1h	2h	3h	4h	5h	6h	8h	10h	20h
1.85V/cell	583.4	495.0	451.8	406.5	342.0	280.0	235.5	156.0	120.3	97.1	81.9	71.4	57.0	47.8	25.3
1.80V/cell	710.0	579.0	514.9	457.5	377.0	304.0	255.3	166.5	126.3	101.3	85.3	74.0	59.4	50.0	26.5
1.75V/cell	829.8	666.0	582.5	513.0	413.0	331.3	278.8	176.0	132.5	106.3	88.8	76.8	61.0	51.0	27.0
1.70V/cell	949.7	747.0	643.8	558.0	444.0	351.3	295.0	184.8	138.3	110.0	91.4	79.2	62.8	52.3	27.7
1.67V/cell	1019.6	804.0	694.0	600.0	470.0	366.7	307.5	192.0	142.7	113.1	94.0	81.0	63.6	53.1	28.1
1.60V/cell	1110.0	861.0	736.0	630.0	491.0	382.7	320.6	199.3	146.1	115.6	95.9	82.5	64.8	53.6	28.4

### Constant Power Discharge (Watts/cell) at 35 °C (95°F)

F. V/Time	5min	10min	15min	20min	30min	45min	1h	2h	3h	4h	5h	6h	8h	10h	20h
1.85V/cell	1089.5	931.2	855.4	773.2	653.6	538.4	455.5	303.4	235.1	190.5	161.3	141.1	113.1	95.1	50.4
1.80V/cell	1304.3	1073.5	962.3	861.0	714.7	580.6	491.1	322.3	245.7	197.9	167.3	145.6	117.5	99.3	52.7
1.75V/cell	1497.9	1215.1	1073.3	954.4	777.0	629.1	533.9	339.3	257.1	207.0	173.6	150.6	120.4	101.2	53.7
1.70V/cell	1685.7	1343.9	1174.2	1029.3	828.3	662.5	561.9	354.7	267.4	213.4	178.2	155.1	123.9	103.6	55.0
1.67V/cell	1777.1	1424.8	1249.9	1094.9	870.3	687.5	582.4	367.1	274.7	218.7	182.5	158.2	125.2	105.1	55.8
1.60V/cell	1894.8	1496.0	1303.6	1136.5	900.0	710.8	603.0	378.6	279.7	222.6	185.5	160.6	127.1	105.9	56.1

### Discharge Characteristics

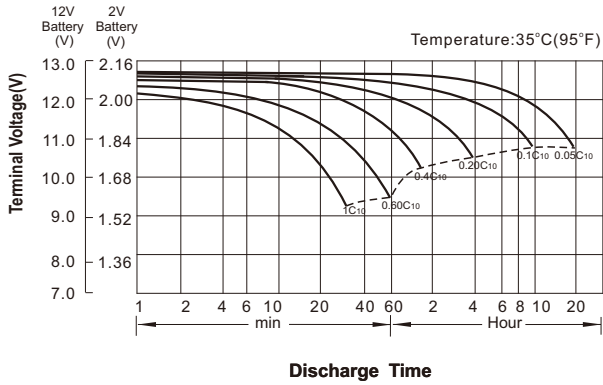

### Float Charging Characteristics

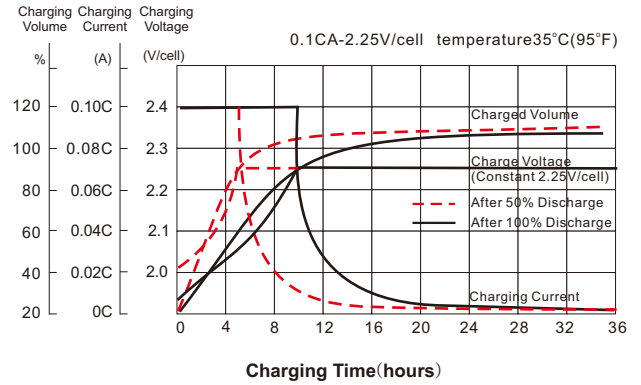

### Temperature Effects in Relation to Battery Capacity

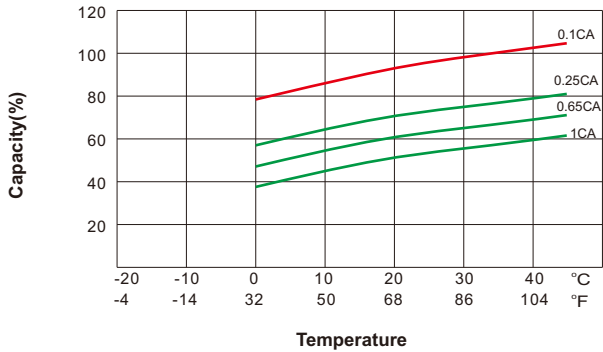

### Effect of Temperature on Long Term Float Life

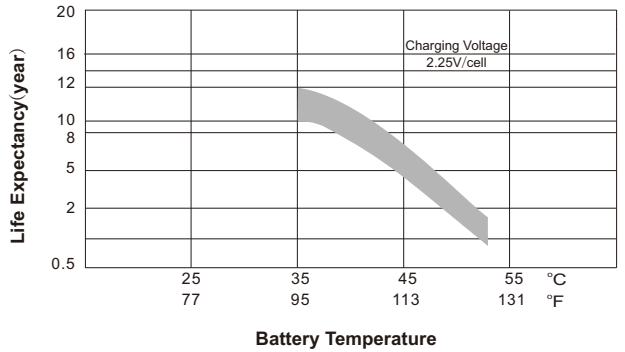

### Cycle Life in Relation to Depth of Discharge

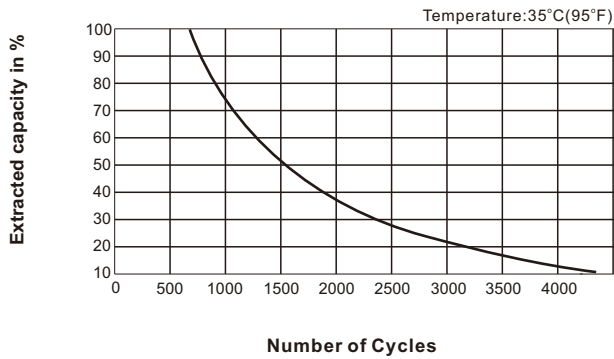

### Self Discharge Characteristics

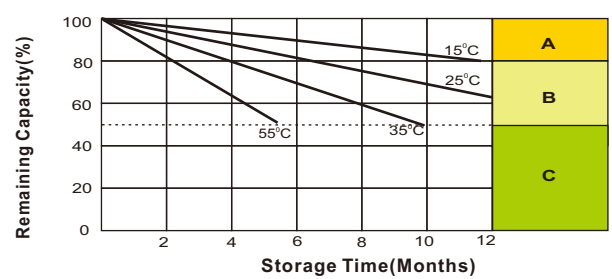

- A** No supplementary charge required (Carry out supplementary charge before use if 100% capacity is required.)
- B** Supplementary charge required before use. Optional charging way as below:  
 1. Charged for above 3 days at limited current 0.25CA and constant voltage 2.25V/cell.  
 2. Charged for above 20 hours at limited current 0.25CA and constant voltage 2.45V/cell.  
 3. Charged for 8-10 hours at limited current 0.05CA.
- C** Supplementary charge may often fail to recover the capacity. The battery should never be left standing till this is reached.

### Sales Office

**China sales office:**  
 Add: 5th Floor, Xinbaohui Bldg., Nanhai Blvd.,  
 Nanshan, Shenzhen, China. 518052  
 Tel: +86-755-86036060 (100 lines)  
 Fax: +86-755-26067269  
 E-mail: export@leoch.com  
 Http://www.leoch.com

**HongKong sales office:**  
 Workshop C, 33/F, TML Tower,  
 No. 3 Hoi Shing Road, Tsuen Wan,  
 New Territories, Hong Kong  
 Tel: +852 35786666  
 Fax: +852 21170016  
 E-mail: sales.hk@leoch.com

**Singapore sales office:**  
 Add: No. 1 Tech Park Crescent,  
 Singapore 638131  
 Tel: +65 68636078  
 Fax: +65 68636079  
 Email sales.sg@leoch.com  
 Http://www.leoch.com

**North America sales office:**  
 Add: 19751 Descartes, Unit A,  
 Foothill Ranch, CA 92610, USA  
 Tel: 949-588-5853  
 Fax: 949-588-5966  
 E-mail: sales@leoch.us  
 Http://www.leoch.us

**Europe sales office:**  
 Add: 1 Deligiorgi St., 121 31 Athens Greece  
 Tel.: +30 210 5760318  
 E-mail: Elia.mitropoulou@leoch.com  
 Http://www.leoch.com