

# LPGS SERIES-TRUE Hybrid GEL Battery

## LPGS2-600 (2V600AH)

### Specification

Nominal Voltage	2V	
Nominal Capacity(10HR)	600.0AH	
Dimension	Length	300±3mm (11.81 inches)
	Width	175±2mm ( 6.89 inches)
	Container Height	330±3mm (12.99 inches)
	Total Height (with Terminal)	340±3mm (13.39 inches)
Approx Weight	Approx 36.8 kg (81.14lbs)	
Terminal	T11	
Container Material	ABS	
Rated Capacity	622.0 AH/31.1A	(20hr, 1.80V/cell, 25°C/77°F)
	600.0 AH/60.0A	(10hr, 1.80V/cell, 25°C/77°F)
	512.0 A H/102.4A	(5hr, 1.75V/cell, 25°C/77°F)
	444.9 AH/148.3A	(3hr, 1.75V/cell, 25°C/77°F)
	353.0 AH/353.0A	(1hr, 1.67V/cell, 25°C/77°F)
Max. Discharge Current	4200A (5s)	
Internal Resistance	Approx 0.66mΩ	
Operating Temp. Range	Discharge	-20~55°C (-4~131°F)
	Charge	0~40°C (32~104°F)
	Storage	-20~50°C (-4~122°F)
Nominal Operating Temp. Range	25±3°C (77±5°F)	
Cycle Use	Initial Charging Current less than 150.0A. Voltage	
	2.4V~2.5V at 25°C(77°F)Temp. Coefficient -5mV/°C	
Standby Use	No limit on Initial Charging Current Voltage	
	2.25V~2.3V at 25°C(77°F)Temp. Coefficient -3mV/°C	
Capacity affected by Temperature	40°C (104°F)	103%
	25°C (77°F)	100%
	0°C (32°F)	86%
Self Discharge	LPGS series batteries may be stored for up to 6 months at 25°C(77°F) and then a freshening charge is required. For higher temperatures the time interval will be shorter.	



### Applications

- ◆ Telecommunications
- ◆ Solar system
- ◆ Wind power system
- ◆ Engine starting
- ◆ Wheelchair
- ◆ Floor cleaning machines
- ◆ Golf trolley
- ◆ Boats



### Constant Current Discharge (Amperes) at 25 °C (77°F)

F.V(Time)	10min	15min	20min	30min	45min	1h	2h	3h	4h	5h	6h	8h	10h	20h
1.85V/Cell	680.4	600.0	540.0	446.7	354.2	286.3	178.2	143.2	113.1	97.3	83.3	67.1	57.2	30.4
1.80V/Cell	804.5	681.6	601.2	479.4	372.6	300.4	188.0	150.6	118.2	102.1	87.0	69.7	60.0	31.1
1.75V/Cell	907.2	748.8	648.1	507.6	391.8	302.5	195.7	151.3	122.1	102.9	89.1	71.0	60.5	31.5
1.70V/Cell	973.9	799.2	693.1	532.6	404.5	304.2	201.5	152.7	124.8	103.6	90.6	72.1	60.9	31.9
1.67V/Cell	1010.1	820.9	710.1	545.6	415.5	312.4	204.5	153.8	126.1	104.3	91.4	72.6	61.3	32.0
1.60V/Cell	1087.4	867.7	741.0	568.5	430.2	324.1	210.1	155.4	128.4	105.9	92.8	73.6	62.3	32.4

### Constant Power Discharge (Watts) at 25 °C (77°F)

F.V(Time)	10min	15min	20min	30min	45min	1h	2h	3h	4h	5h	6h	8h	10h	20h
1.85V/Cell	1279.2	1135.2	1026.3	853.9	681.2	553.0	345.9	278.8	221.3	191.1	164.1	132.8	113.5	60.3
1.80V/Cell	1488.3	1271.4	1129.2	908.2	711.0	576.8	363.2	291.2	230.3	199.7	170.8	137.5	118.8	61.6
1.75V/Cell	1652.0	1377.1	1203.2	952.8	742.1	578.9	376.9	292.9	237.4	200.4	174.3	139.8	119.6	62.5
1.70V/Cell	1746.4	1453.1	1274.4	992.1	762.1	580.1	386.3	293.9	241.7	201.2	177.1	141.8	120.4	63.1
1.67V/Cell	1792.5	1478.6	1294.9	1007.6	778.0	592.3	390.8	294.7	243.7	202.0	178.2	142.5	121.0	63.3
1.60V/Cell	1883.2	1531.9	1332.3	1039.2	798.4	609.4	398.6	297.7	246.9	204.4	180.3	144.1	122.8	64.0

Specifications subject to change without notice.

## Dimensions

### T11 Terminal

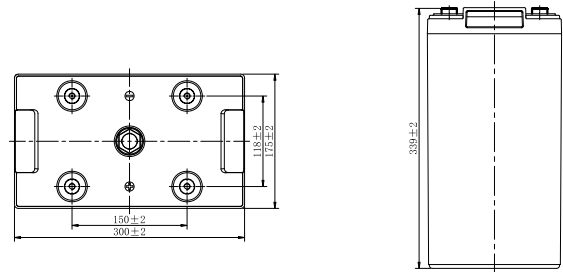
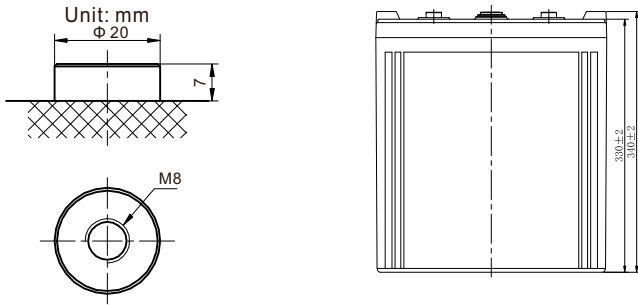

## Discharge Characteristics

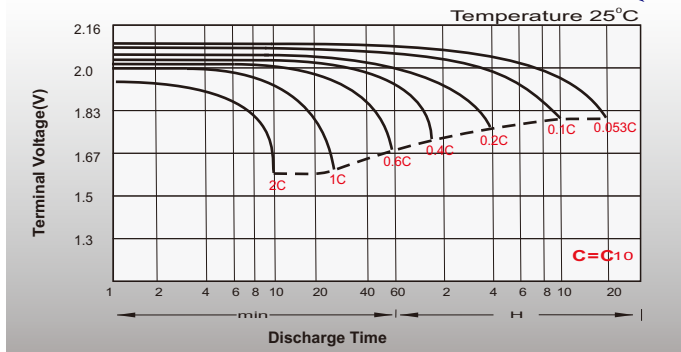

## Float Charging Characteristics

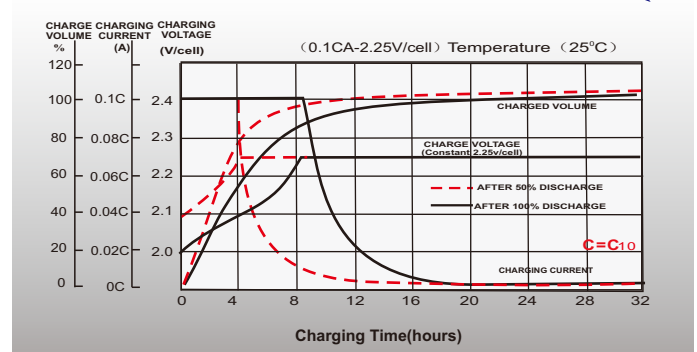

## Temperature Effects in Relation to Battery Capacity

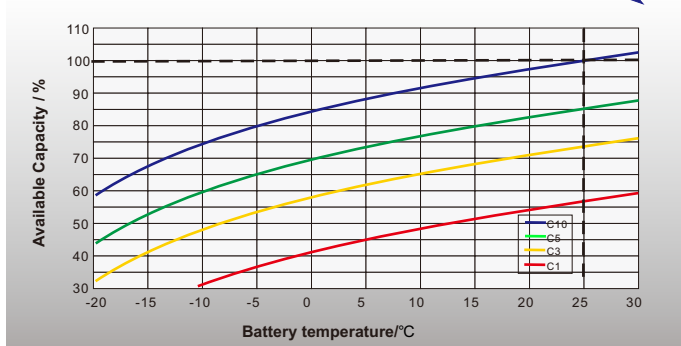

## Effect of Temperature on Long Term Float Life

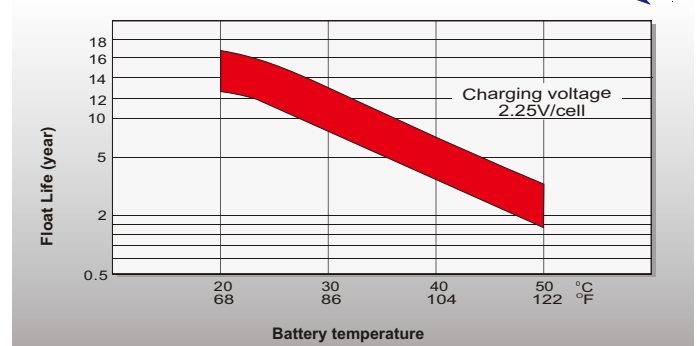

## Cycle Life in Relation to Depth of Discharge

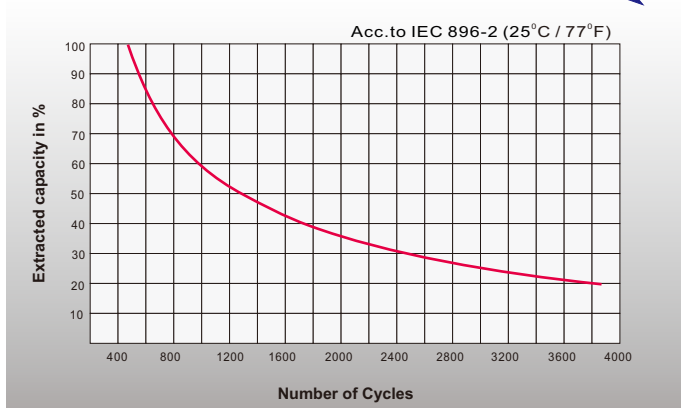

## General Relation of Capacity VS. Storage Time

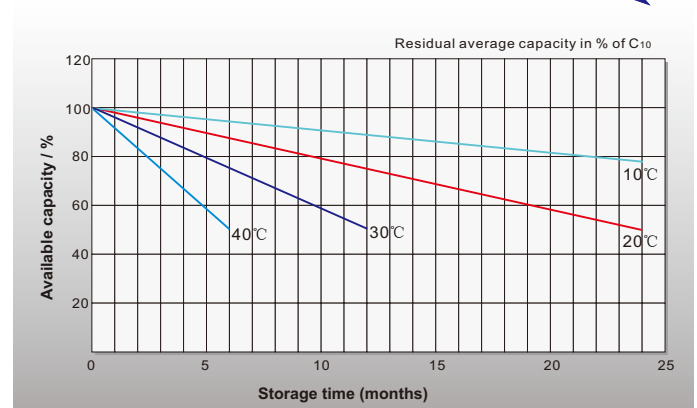

## Sales Office

### China sales office:

Add: 5th Floor, Xinbaohui Bldg., Nanhai Blvd.,  
Nanshan, Shenzhen, China. 518052  
Tel: +86-755-86036060 (100 lines)  
Fax: +86-755-26067269  
E-mail: export@leoch.com  
Http://www.leoch.com

### HongKong sales office:

Workshop C, 33/F, TML Tower,  
No. 3 Hoi Shing Road, Tsuen Wan,  
New Territories, Hong Kong  
Tel: +852 35786666  
Fax: +852 21170016  
E-mail: sales.hk@leoch.com

### Singapore sales office:

Add: No. 1 Tech Park Crescent,  
Singapore 638131  
Tel: +65 68636078  
Fax: +65 68636079  
Email sales.sg@leoch.com  
Http://www.leoch.com

### North America sales office:

Add: 19751 Descartes, Unit A,  
Foothill Ranch, CA 92610, USA  
Tel: 949-588-5853  
Fax: 949-588-5966  
E-mail: sales@leoch.us  
Http://www.leoch.us

### Europe sales office:

Add: 9B Wheatstone Court. Waterwells  
Business Park, Gloucester, GL2-2AQ,  
UK United Kingdom  
Tel: +44(0) 1452 729428 / 1452 729696  
Fax: +44 (0)1452-690125  
E-mail: Sales.Europe@leoch.com