



ENERGY STORAGE BATTERY - GEL ENERGY STORAGE SERIES

MODEL: OT120-12(GEL)/CN

NO.: 302080001-00036



Plane Chart:

Unit:(mm) Terminal type:(T2)

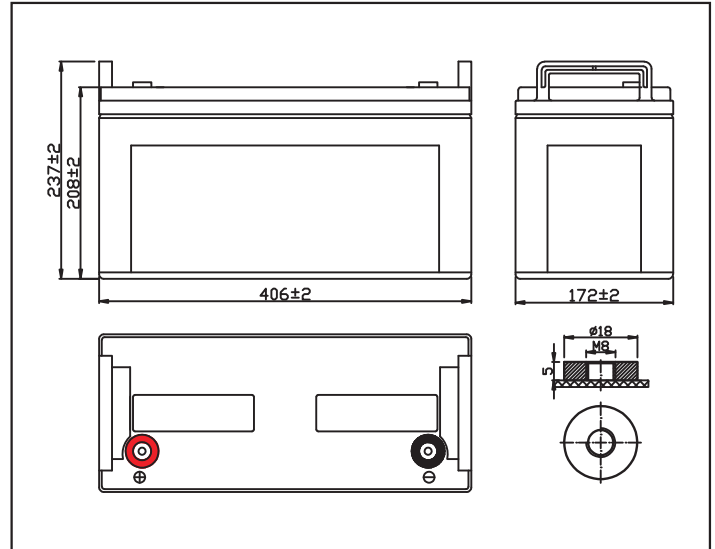

Parameter Chart:

Volts		12V	
Capacity(25°C)	10 hours rate (12A)	120Ah	
Discharge Current Testing (25°C)	1 hours rate (66A)	72Ah	
	3 hours rate (30A)	93Ah	
Internal Resistance	Full Charged Battery 25°C	5mΩ	
Capacity Affected By Temperature	40°C	104%	
	25°C	100%	
	0°C	83%	
	-15°C	65%	
Residual Capacity (25°C)	Capacity After 3 Months Storage	91%	
	Capacity After 6 Months Storage	82%	
	Capacity After 12 Months Storage	65%	
Charge (Constant Voltage)	Cycle (25°C)	Initial Charging Current Less Than 36A Voltage 14.5~14.9V	
	Float (25°C)	Charge Voltage 13.6~13.8V	
Weight (Approx)		36.6Kg	

Residual Capacity

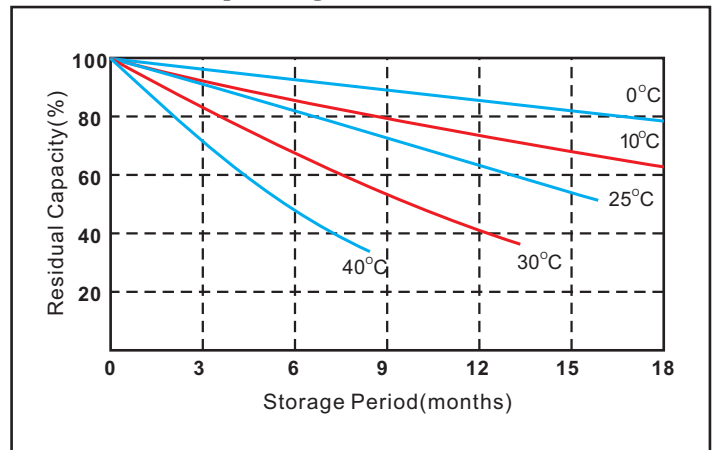

Discharge Current 25°C

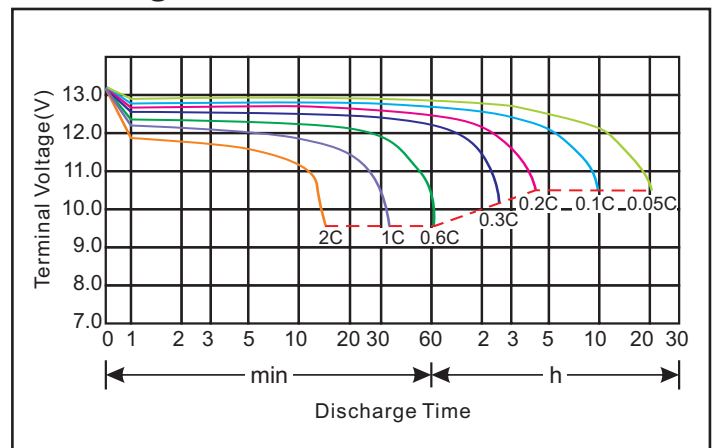

★The above are average and data obtained from the first 3 charge/discharge cycles. These are not minimum values.

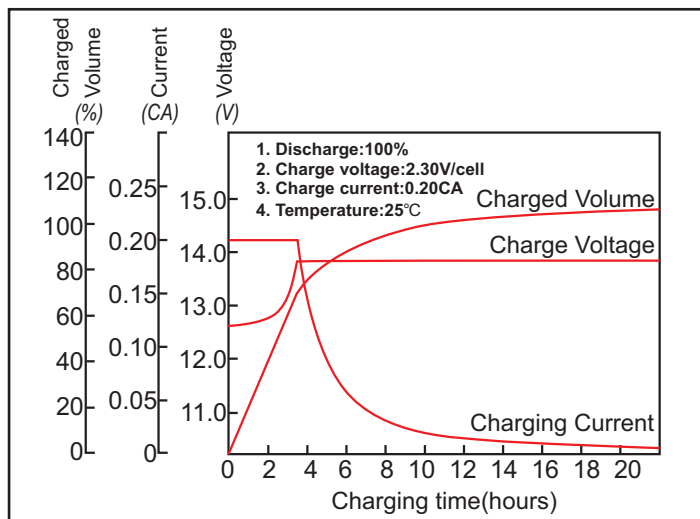
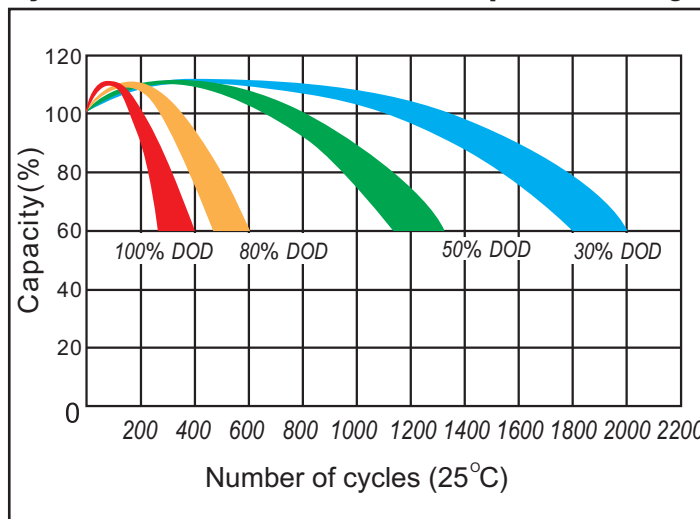
MODEL: OT120-12(GEL)/CN
NO.: 302080001-00036
Constant voltage charging characteristics

Cycle service life in relation to the depth of discharge

Constant Current Discharge Characteristics (A, 25°C)

F.V/Time	10min	15min	30min	60min	2h	3h	5h	8h	10h	20h
9.60V	239.6	205.1	125.3	71.9	42.9	31.5	21.4	13.2	12.2	6.3
10.2V	229.8	197.6	121.2	69.8	42.3	30.6	20.9	12.8	12.1	6.2
10.5V	214.5	187.6	118.2	67.2	42.1	29.8	20.6	12.3	12.0	6.2
10.8V	198.6	174.5	116.1	64.6	41.4	28.7	20.3	11.8	12.0	6.1

Constant Power Discharge Characteristics (Watt, 25°C)

F.V/Time	10min	15min	30min	60min	2h	3h	5h	8h	10h	20h
9.60V	2635.6	2256.1	1441.0	826.9	497.6	365.4	248.2	160.1	141.8	73.1
10.2V	2550.6	2213.1	1405.9	809.7	490.7	354.5	244.8	156.6	140.6	71.9
10.5V	2402.8	2119.9	1382.9	786.2	488.4	345.7	242.4	152.0	139.5	72.4
10.8V	2244.3	1989.3	1370.0	762.3	480.2	332.9	236.6	146.2	138.3	70.8

Capacity Factors With Different Temperature

Battery Type		-20°C	-10°C	0°C	5°C	10°C	20°C	25°C	30°C	40°C	45°C
GEL Battery	12V	50%	70%	83%	85%	90%	98%	100%	102%	104%	105%

★The above are average and data obtained from the first 3 charge/discharge cycles. These are not minimum values.