

Lithium ion Battery Specification

Battery Type: 51.2V100Ah
Wall-mounted Design BESS
CSF-C-5kWh

Shenzhen Huaxing New Energy Technology Co., Ltd.

Address: NO. 18, Mingcheng Road, Shijing Community, Shijing Street, Pingshan District,
Shenzhen

Tel.:+86 0755-89458220

Email: huaxing@huaxingenergy.com

www.huaxingenergy.com

Specification of 5kWh-51.2V100Ah Lithium Ion Batteries

1. Description and Model

1.1 Battery Type: LiFePO4 51.2V100Ah

1.2 Battery Model: CSF-C-5kWh(Wall-mounted Design)

2. Technical Parameters

2.1 Cell Parameters

Item	Condition	Specification	Mark
Nominal Capacity	1C discharge capacity	100Ah	
AC Internal Resistance	At 1000 Hz	≤1mΩ	
Nominal Voltage		3.2V	
Dimension(Length*Thickness*Height)	Width	122*26*315.2 mm	
Weight		2.2±0.04Kg	
Charge Cutoff Voltage	CC Charge	3.65V	
Charge Cutoff Current	CC Charge	≤5A	
Charge Method	Standard charge	≤0.5 C at CC/CV	
Discharge Cutoff Voltage	CC discharge	2.5V	
Max. Continuous Discharge Current		300A	25°C
Cycle Lifetime		≥6000 cycles	
Working Temperature	Charge	5~45 °C	
	Discharge	-20~ 60°C	
	Storage	-20~ 25°C	≤12 months

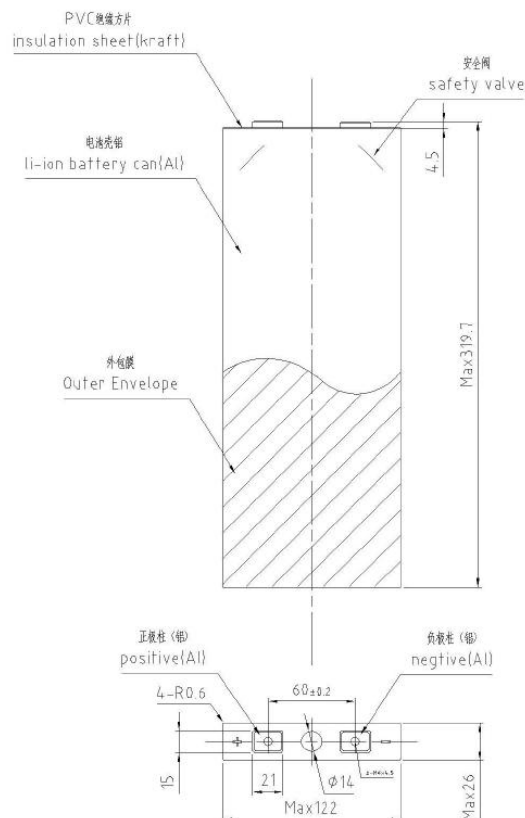

Specification of 5kWh-51.2V100Ah Lithium Ion Batteries

2.2 Battery Pack Parameters

Item	Specification	Mark
5KWh-51.2V100Ah LiFePO4 Battery		
Composition	16S1P	16PCS
Nominal capacity	100Ah	
Nominal Voltage	51.2V	
Dimensions(W*D*H)	590*91*1090mm	
Weight	60kg	
Charge Cutoff Voltage	58.4V	
Charge Cutoff Current	≤5A	
Charge Method	CC/CV	
Discharge Cutoff Voltage	40V	
Max. Continuous Discharge Current	100A	
Recommended charge current	100A	
Maximum charge current	200A	
Continuous discharge current	100A	
Maximum discharge current	200A	
Charge Current Limiting	10A	When parallel connection and over using
Self-discharge	25°C, not more than 5% per month	
Balancing Function	Start voltage: 3.38V Start voltage difference: 30mV	
DOD	80%	
Cycle Life	≥4000 cycles	
Communication	RS485 for parallel connection, double RS485/RS232/CAN	
Main Functions	Protection for over charge, over discharge, over temperature, over current, short circuit, LED status indicator, precharging, charging balancing, charging current limiting function, with display	
Working Temperature	Charge	0~45 °C
	Discharge	-20~ 60°C
	Storage	0~ 45°C
Certificate	IEC62619, CE, ROHS, UN38.3, MSDS	
Recommended Inverter power	5.0kW	

2.3 BMS Parameters

Item	Parameter
Output Voltage	Working range 36V-60V
Working Current	Working range ≤100A
Operation Temperature	Working range -20°C ~ +70°C
Self-consuming	Under operation ≤100μA
Internal Resistance	≤10mΩ

Specification of 5kWh-51.2V100Ah Lithium Ion Batteries

Over Charge Protection	Protection Voltage	3.75±0.05V
	Recovery Voltage	3.34±0.1V
	Over voltage protection delay	0.50 ~ 1.50S
Over Discharge Protection	Protection Voltage	2.50±0.1V
	Recovery Voltage	2.90±0.1V
	Low voltage protection delay	50.00~150.00ms
Over Current Protection	Charge Over Current Protection	100A, delay 4s
	Discharge Over Current Protection #1	100A, delay 4s
	Discharge Over Current Protection #2	125A, delay 300ms
Short Circuit Protection	Protection Delay	500us
	Recovery Condition	Cutoff load
Temperature Protection	Overheat Protection Temperature	65±2°C
	Recovery Temperature/Time	50±2°C
Charge Balancing	Charge Balancing Open Voltage	3.5±0.050V
Communication Interface		RS485
Scalability		Max. 16 units

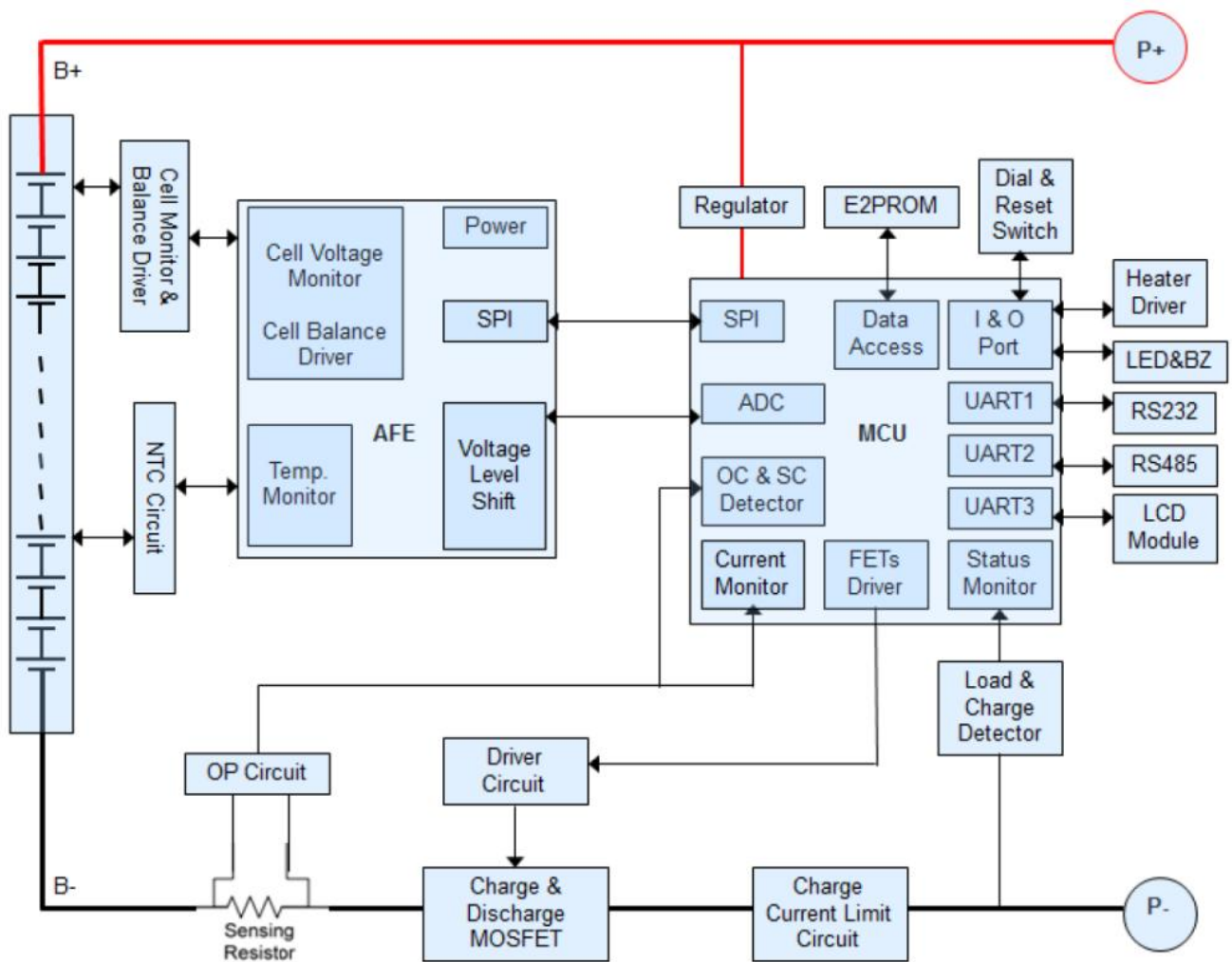

BMS functional diagram

Specification of 5kWh-51.2V100Ah Lithium Ion Batteries

3. Dimensions

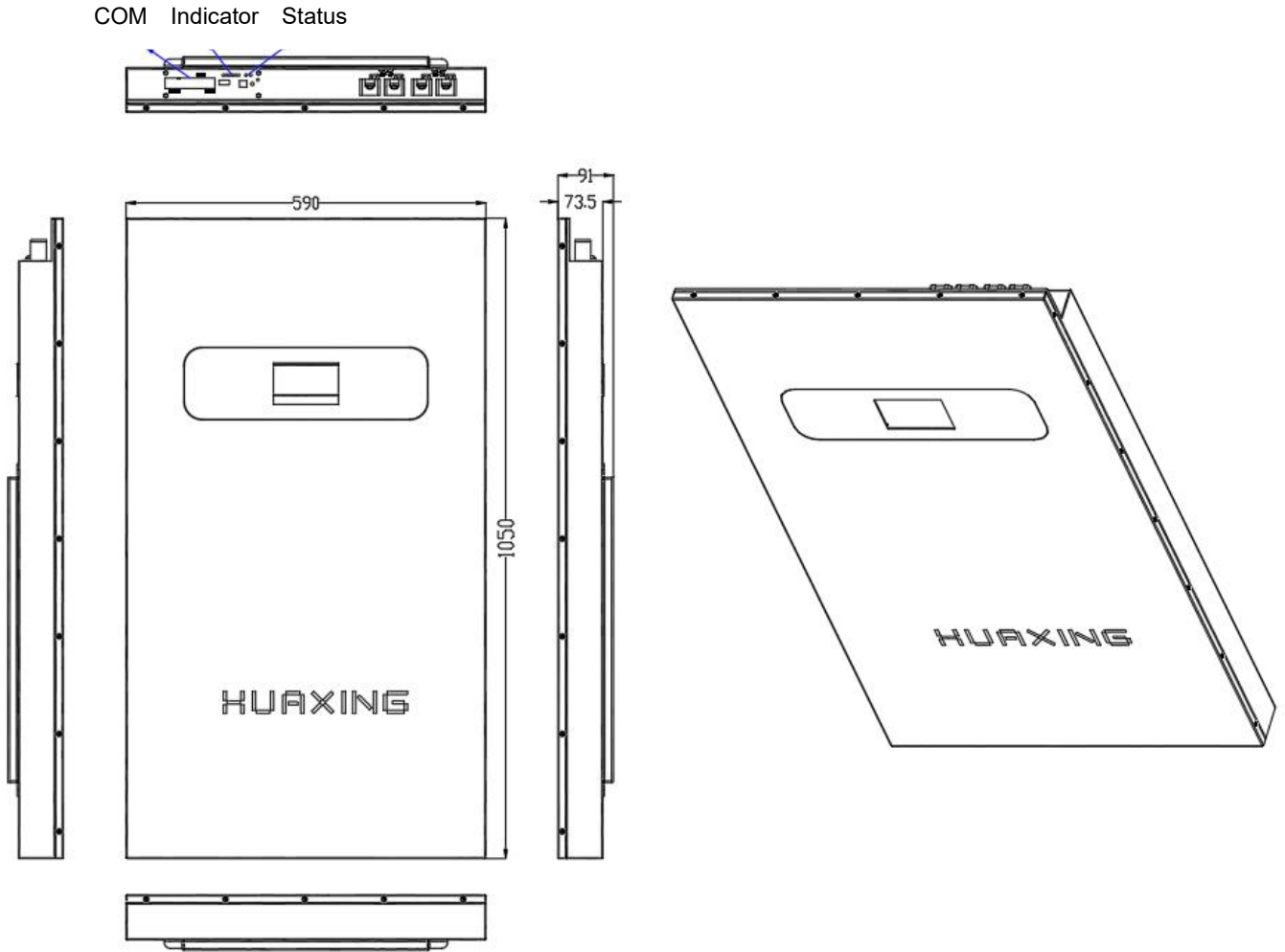

4. System Connection

4.1 Wiring Diagram of Battery Parallel Connection

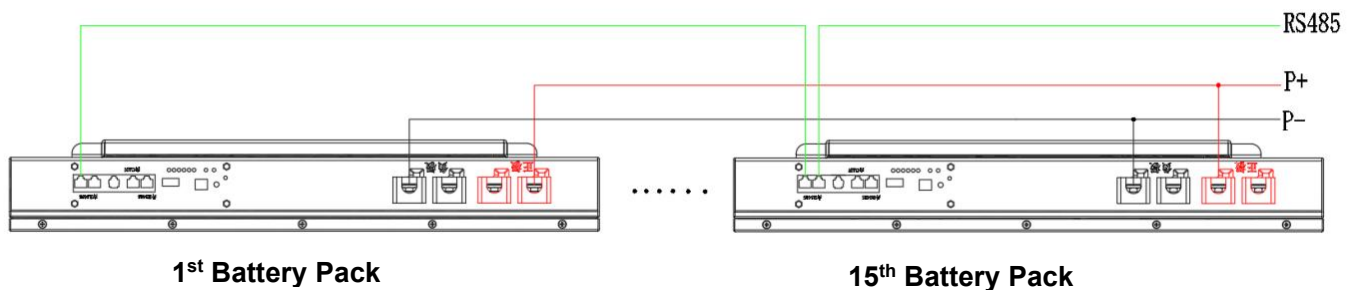



(Red cable-Positive, Black cable-Negative, Green cable-communication)

Specification of 5kWh-51.2V100Ah Lithium Ion Batteries

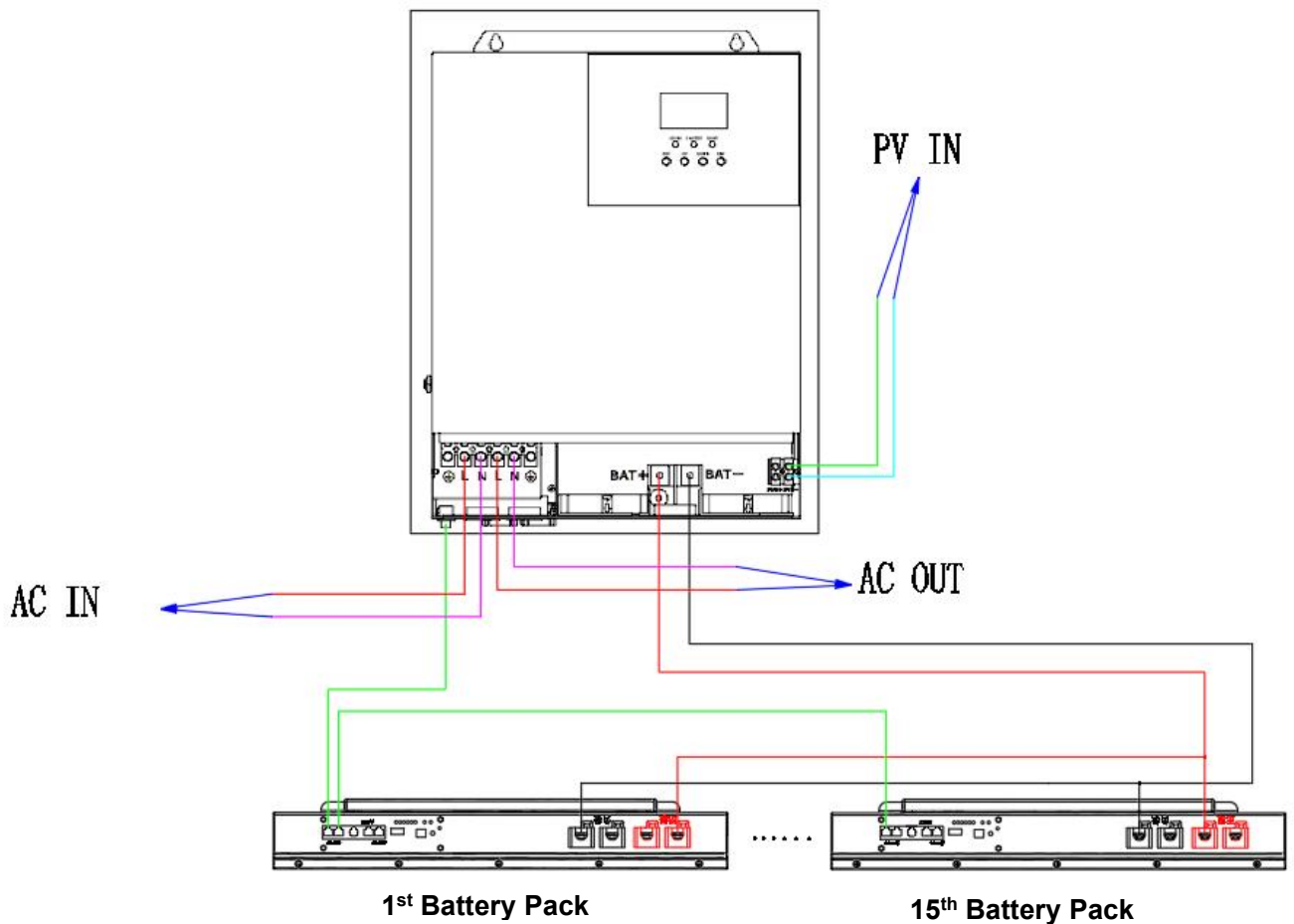
4.2 4.2 System Wiring Diagram



5. Label

HUAXING	Lithium Ion Batteries LiFePO4
Model	CSF-C-10kWh(Cabinet Design)
Rated Voltage	51.2V
Rated Capacity	100Ah
Rated Energy	5.12kWh
Max. Charge/Discharge Current	100A/5kW
Date Code	YY/MM
CE CB UN38.3 MSDS  	
 CAUTION!	
WARNING/STORAGE/TRANSPORTATION:	

Specification of 5kWh-51.2V100Ah Lithium Ion Batteries

- ✧ **USER MUST READ INSTRUCTION MANUAL BEFORE OPERATING**
- ✧ **DO NOT CONNECT IN SERIES**
- ✧ **DO NOT SHORT THE BATTERY TERMINALS**
- ✧ **DO NOT OVERCHARGE OR OVERDISCHARGE**
- ✧ **DO NOT INCINERATE, CRUSH OR DISASSEMBLE**
- ✧ **DO NOT CONNECT IN REVERSE POLARITY**
- ✧ **DO NOT DISPOSE OF IN FIRE**
- ✧ **DO NOT OPERATE BEYOND PUBLISHED VOLTAGE, CURRENT AND TEMPERATURE LIMITS**
- ✧ **DO NOT STORE ABOVE 45°C**
- ✧ **THE BATTERY SHOULD BE CHARGED WITH 50% SOC FOR STORAGE AND TRANSPORTATION**
- ✧ **THE BATTERY SHOULD BE STORED IN DRY AND VENTILATED PLACE, AND RECHARGED EVERY 3 MONTHS**

Manufacturer: SHENZHEN HUAXING NEW ENERGY TECHNOLOGY CO., LTD
Made in China

6. Package/Storage/Transportation

5.1 Package and Transportation

All delivered goods shall comply with the global packaging and transportation labeling requirements and shall have sturdy packaging suitable for long-distance transportation, multiple handling and loading and unloading, to ensure that the products are intact during transportation, loading and unloading, and have measures to reduce vibration and shock. The packaging should be protected against moisture, mildew, rust and corrosion as needed according to the characteristics of the product, so as to ensure that the goods are safely delivered to the place agreed in the contract without any damage and corrosion. Before the product is packaged, our company is responsible for inspection and cleaning, leaving no foreign matter, and ensuring that the parts are complete.

5.2 Storage

- (1) According to the characteristics of the battery, the LiFePO₄ battery pack should meet the environmental conditions of its storage to maximize the protection of the battery performance.
- (2) During the storage and transportation of LiFePO₄ battery pack, there should be appropriate protection; maintain a SOC level of about 50%; ensure that there will be no short circuit and liquid entering the battery or immersed in liquids (such as water, oil, etc.);
- (3) If not in use temporarily, the battery should be stored in a dry, clean and well-ventilated warehouse at 0°C ~ 45°C.
- (4) During the process of loading and unloading, the battery should be handled with care, to prevent throwing, rolling and heavy pressure.



Cautions!

7. Use Guidelines

Misuse of the rechargeable Li-ion battery may cause damage to the battery or personal injury. Before using the battery, please read the following safety rules carefully.

- Do not expose the battery to extreme heat or ignition sources.
- Do not short-circuit, overcharge or overdischarge the battery.
- Do not subject the battery to excessive mechanical shock.

Specification of 5kWh-51.2V100Ah Lithium Ion Batteries

- Do not immerse the battery in seawater or water, or allow it to get wet.
- Do not disassemble or trim the battery.
- Do not place batteries and metal objects such as necklaces, coins or hairpins together.
- Do not subject the battery to obvious damage or deformation.
- Do not mix lithium-ion batteries.
- Do not place the battery in direct sunlight.
- Keep the battery away from children.
- Do not acupuncture, beat or trample on the battery.

8. Brief Instructions on Battery Using

During charging, if there is a strange smell or abnormal sound, please stop charging immediately.

During use, if there is any odor or abnormal sound, stop using it immediately.

If the above phenomenon occurs, please contact the manufacturer immediately and do not disassemble it without permission.