



Monofacial

Bifacial

LP182*182-M-72-MH

Rated Power 540-560W

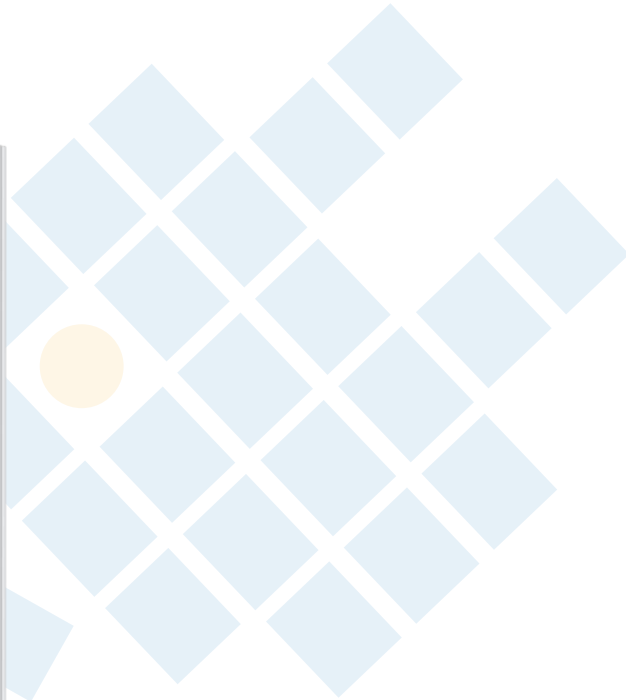
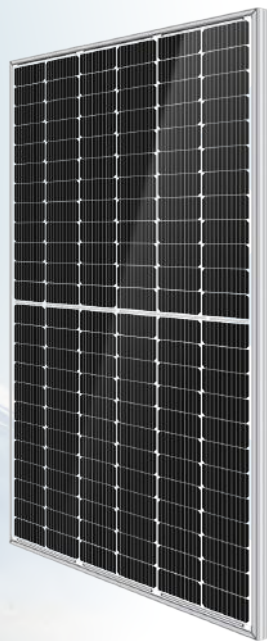

- No risk of spontaneous detonation
- Bifacial Module is 30% lighter than Dual-Glass Module
- Bifacial cells, provide an additional output
- Ability to breath, The inner CH3COOH can be released

MBB Cell
New circuit design, lower internal current, lower internal resistance loss.

Low Light Features
Higher performance under low light environment.

Higher Output Power
Module adopts 182*182mm half cells, bifacial module provide an additional 5%~25% output.

PID Protection
Ensure the attenuation probability caused by PID phenomenon is minimized.

Harsh Environmental Adaptability
Strict salt spray and ammonia corrosion test by TUV Nord.

Load Capacity
Mechanical load tests including wind load 2400 Pa and snow load 5400 Pa done by TUV Nord.

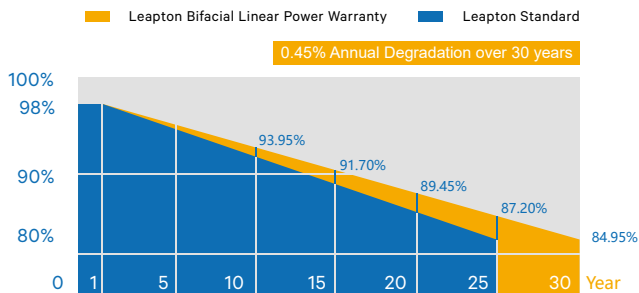

Headquarter : Leapton Energy Co., Ltd.

Tosei Bldg. 6F, 1-2-1 Aioi-cho, Chuo-ku Kobe-shi, Hyogo, 650-0025, Japan

+81-78-382-3182

www.leaptonenergy.jp

Manufacturer : Leapton Solar (Changshu) Co., Ltd.

No.9, Sunshine Avenue, Changshu City, Jiangsu, China

+86-512-88800068

info@leaptonenergy.com

www.leaptonpv.com

MECHANICAL DIAGRAMS

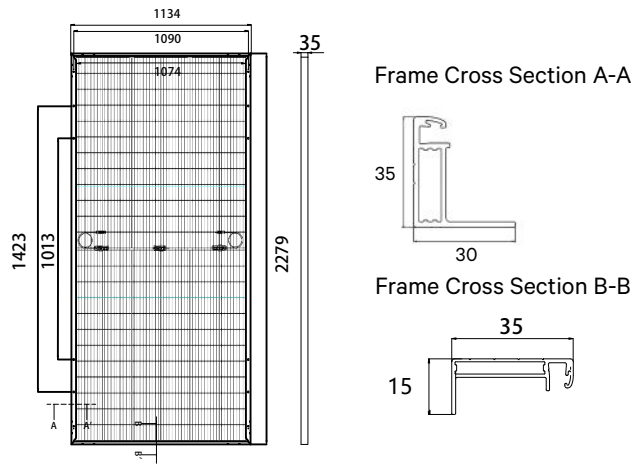

SPECIFICATIONS

Weight	27kg
Dimensions	2279mm*1134mm*35mm
Cell Dimensions	182*182mm
Cell Amount	72*2 pcs
Maximum System Voltage	1500V
Junction Box	IP68
Frame	Aluminum Alloy
Cable	4mm ² , N 300mm/P 300mm or customized length
Connector	MC4 compatible
Application Level	Class A
Bifaciality	70±5%

ELECTRICAL PARAMETERS AT STC

Power	540W	545W	550W	555W	560W
Open Circuit Voltage	49.40V	49.60V	49.80V	50.00V	50.20V
Short Circuit Current	13.87A	13.93A	13.99A	14.05A	14.11A
Maximum Power Voltage	41.20V	41.40V	41.60V	41.80V	42.00V
Maximum Power Current	13.11A	13.17A	13.23A	13.29A	13.33A
Module Efficiency	20.90%	21.09%	21.28%	21.48%	21.67%

* Under Standard Test Conditions (STC) of irradiance of 1000 W/m², spectrum AM 1.5 and cell temperature of 25°C.

ELECTRICAL PARAMETERS AT NMOT

Power	402W	406W	410W	414W	417W
Open Circuit Voltage	46.30V	46.40V	46.60V	46.80V	47.00V
Short Circuit Current	11.18A	11.23A	11.28A	11.33A	11.38A
Maximum Power Voltage	38.40V	38.60V	38.80V	39.00V	39.20V
Maximum Power Current	10.49A	10.54A	10.58A	10.62A	10.64A
Module Efficiency	15.56%	15.71%	15.86%	16.02%	16.17%

* Under Nominal Module Operating Temperature (NMOT), irradiance of 800 W/m², spectrum AM 1.5, ambient temperature 20°C, wind speed 1 m/s.

ELECTRICAL PARAMETERS (AT 10% BIFACIAL POWER OUTPUT)

Output Power	594W	600W	605W	611W	616W
Open Circuit Voltage	49.40V	49.60V	49.80V	50.00V	50.20V
Short Circuit Current	15.26A	15.32A	15.39A	15.46A	15.51A
Maximum Power Voltage	41.20V	41.40V	41.60V	41.80V	42.00V
Maximum Power Current	14.42A	14.48A	14.54A	14.61A	14.67A

TEMPERATURE CHARACTERISTICS

NMOT	41±3°C	Temp Coefficient of ISC	+0.05%/°C
Temp Coefficient of VOC	-0.28%/°C	Temp Coefficient of Pmax	-0.36%/°C

PACKING CONFIGURATION

Modules/Pallet	31 Pieces	Modules/40'Container	620 Pieces
Packing Description	20 Pallets, Total=(31+31)x10=620 Pieces		

CHARACTERISTICS

LP182*182-M-72-MH-540W

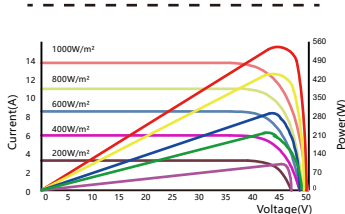

LP182*182-M-72-MH-540W

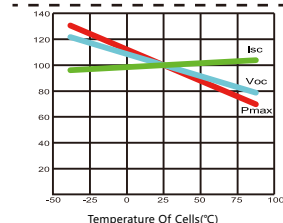

MAXIMUM RATING

Output Tolerance	0~+5W
Operating Temperature	-40°C~+85°C
Wind Load/Snow Load	2400pa/5400pa
Fuse Current	25A



Headquarter : Lepton Energy Co., Ltd.

☑ Tosei Bldg. 6F, 1-2-1 Aioi-cho, Chuo-ku Kobe-shi, Hyogo, 650-0025, Japan

Manufacturer : Lepton Solar (Changshu) Co., Ltd.

☑ No.9, Sunshine Avenue, Changshu City, Jiangsu, China

☎ +81-78-382-3182

🌐 www.leptonenergy.jp

☎ +86-512-88800068

✉ info@leptonenergy.com

🌐 www.leptonpv.com