

Why choose us?

We are committed to providing our customers with high quality new energy products and services, and always focus on customer experience.

We are pleased to see more and more customers commenting favorably on our products and services. Many customers praise the high quality, stability and reliability of our products, but also very satisfied with our professional pre-sale, sale, after-sales service.

Some customers also highlighted the kindness and patience of our staff, who answered their questions in detail and provided solutions.

These favorable comments reflect our efforts and achievements in maintaining our leading position in the market,

And encourage us to continue to improve our products and services to provide even better solutions to our customers.

We will, as always, adhere to the "integrity, quality, innovation, service" business philosophy, committed to promoting clean energy,

To provide customers with better quality products and services.

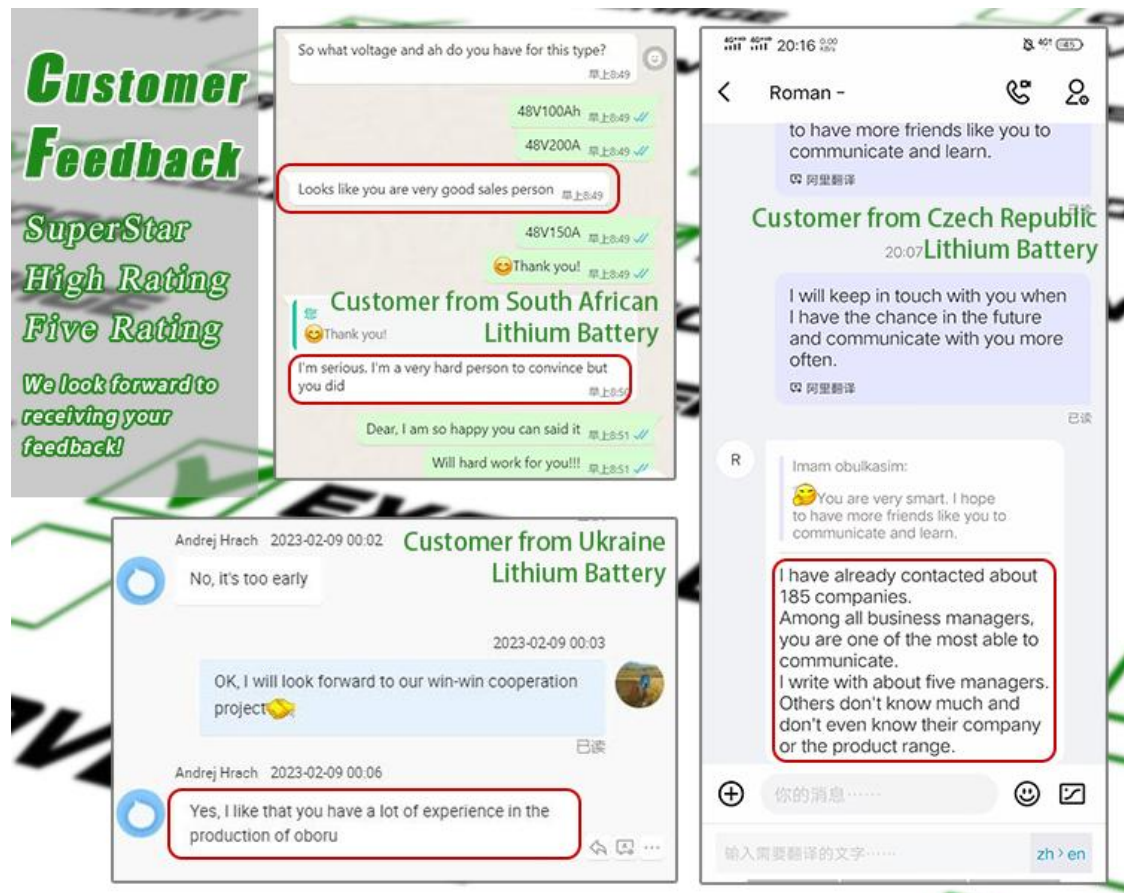

Why choose us?

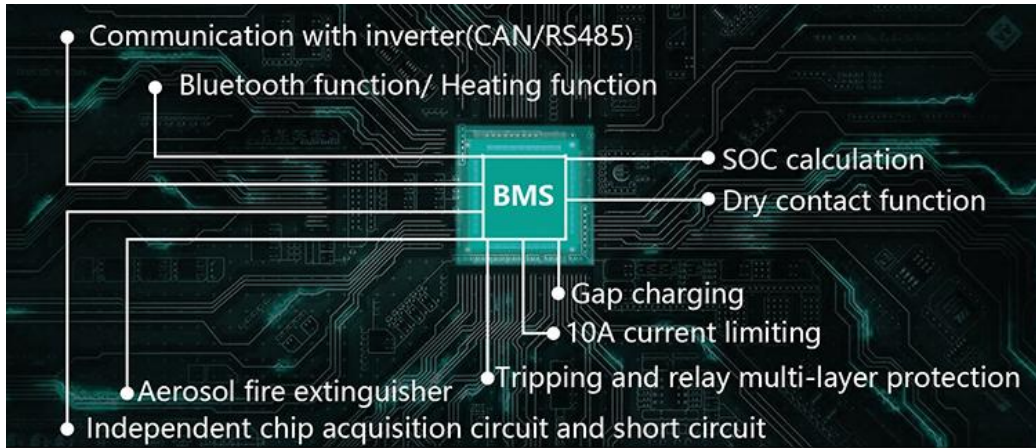

- 1: CAN communicate, report the battery status in real time, and protect the battery in the first time
- 2: trip control, five-fold protection is safer
- 3: BMS hardware protection
- 4: Fuse between the BMS and the battery pack
- 5: Flame retardant grade UL94-V0 grade material
- 6: soft pack cell
- 7: Aerosols



Why choose us?



1. Product Description

- . Long service life: product cycle times: 100% DOD 6000 times
- . The product has high safety, built-in temperature probe, safety alarm extinguisher, double protection function,
- . BMS has the function of active equalization.
- . It is intelligent and can detect voltage and electric quantity to avoid overcharge and overdischarge.
- . All brands of inverter communication can be connected



2. BATTERY STRUCTURE & CHARACTERISTICS

51.2v 100ah Lithium ion Battery Features:

Cycle life >6000 times, upto 10 years

Expandable , battery design, parallel stacking to increase battery capacity CAN

Communication ports 232, Rs485, iempeie w many rns0, inverters

Simple connection between battery . and inverter, easy installation.



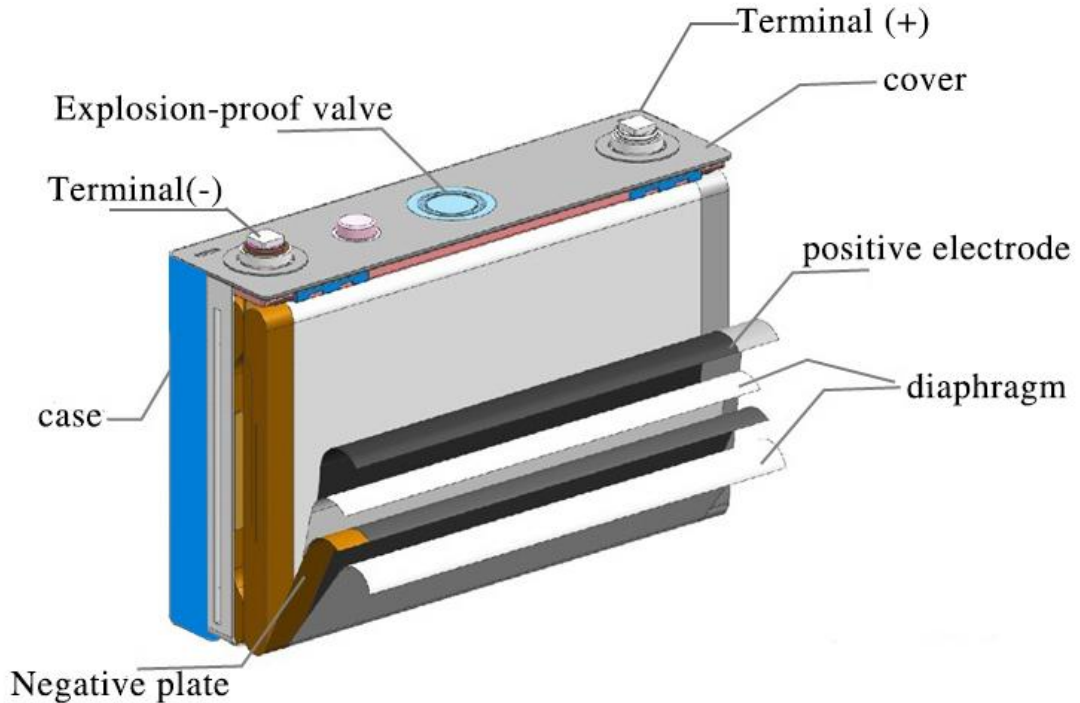
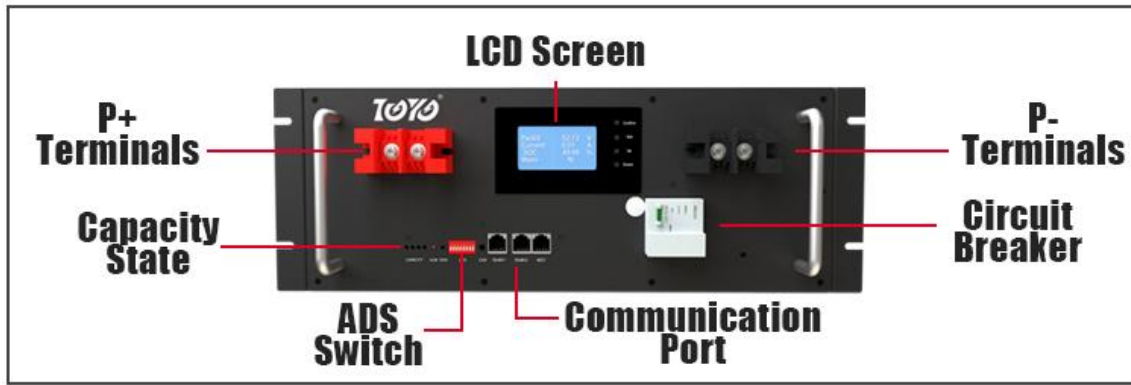

1. A Grade Lifepo4 cells, The service life can reach more than 10 years.
2. Built-in BMS, charge protection, discharge protection, overcurrent protection, temperature protection, short circuit protection.

3. Expandable capacity, support 4 battery packs in series (192V), 6 battery packs in parallel (48v 600Ah).
4. Can completely replace lead-acid batteries, light weight, high energy density, support 0-60 °C environmental discharge

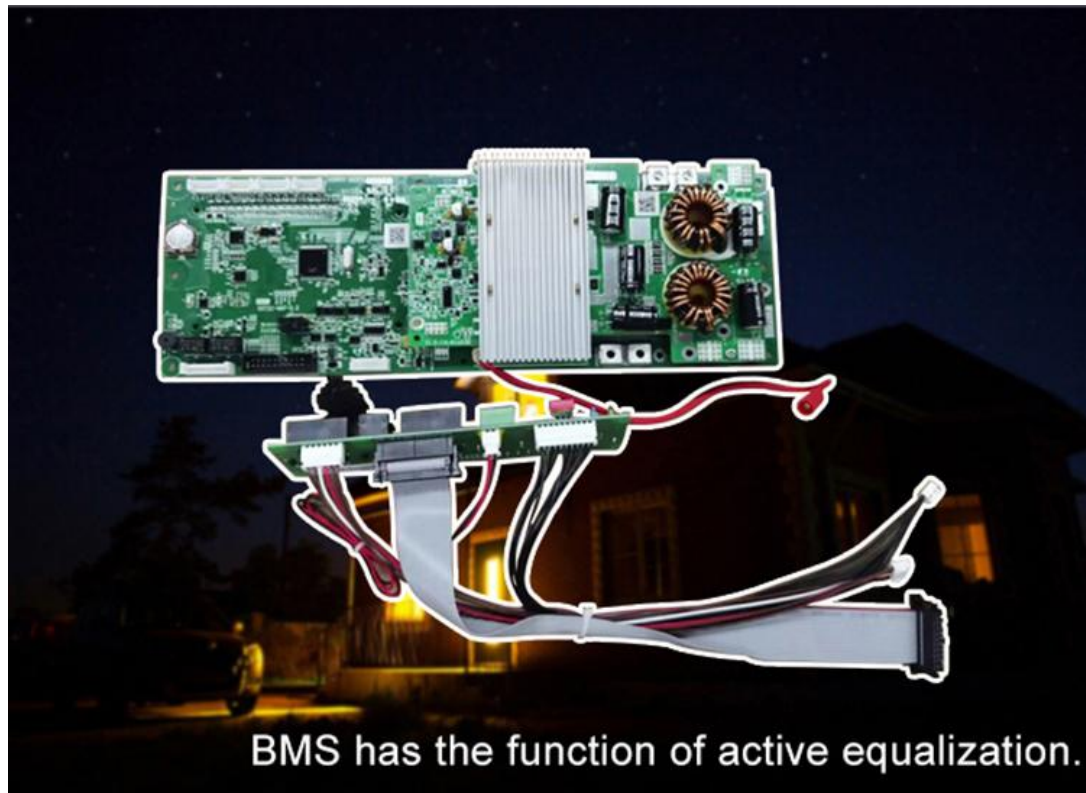

3.Parameter



Basic Parameters	PALA-R
Nominal Voltage (V)	51.2V
Nominal Capacity (Ah)	100Ah
Nominal Power (Wh)	5.12KWh
Dimension (mm)	544.7*482.5*432.4mm
Weight (Kg)	95Kg±3kg
Working voltage range	42V~58.4V
Max. Charge/Discharge Current (A)	100A
Communication Interface	CANBUS,RS485
Configuration	16S4P
Working Temperature	0~40°C (Charge) / -20~40°C (Discharge)
Cell chemistry	Lithium iron phosphate (LiFePO4)

Cycle life	4800 cycles @25°C 50A charge and discharge current 70% standard capacity 90% DOD
IP level	IP 20

4. WIDESPREAD APPLICATION (LiFePo4

Battery)

1. Solar energy storage system
2. Home solar storage system
3. RV, Boat
4. Emergency rescue standby power supply
5. Communication stations
6. Factory solar energy storage system



Functions:

- Overcharge detection function
- Over discharge detection function
- Over current detection function
- Short detection function
- Temperature detection function
- Balance function
- Communicate function RS485,CANBUS
- Alarm function

– Communication interface –

All brands of inverter communication can be connected.



6. Production

According to product quality requirements, the company has established a strict quality management system.

Strictly control and manage all the links related to product quality.

We have established scientific inspection procedures and quantified the inspection indicators to ensure the continuous and stable production of qualified products.

The company strictly controls raw materials to prevent unqualified products from flowing into the production site.



7. Packing & Delivery

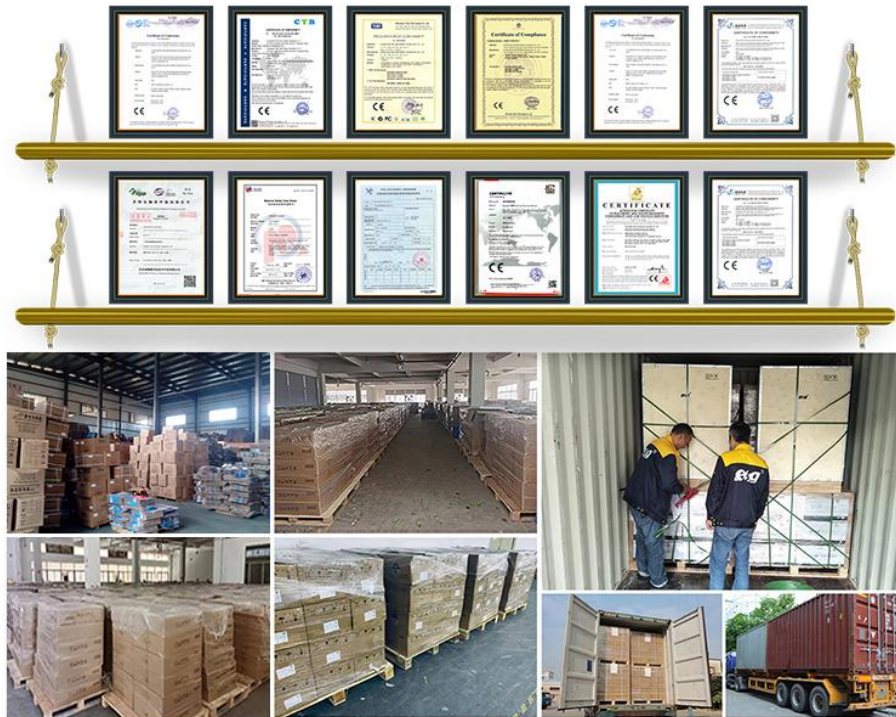

- 1) Inner box - carton - pallet - load on container
- 2) Packaging also can be made by customers requirements

8. Certifications

The company has passed ISO9001 quality system certification, ISO14001:2015 environmental management system certification, and its products have passed a series of international authoritative certifications such as SGS, UN38.3, CE, RoHS, MSDS, CNAS, etc.



9. Our Team

We are committed to providing customers with high quality new energy products and services, always focusing on customer experience. Our products are of high quality, stable and reliable praise, but also to our professional pre-sale, sale, after-sales service is very satisfied. Some customers also made special mention of the kindness and patience of our staff as we answered their questions in detail and provided solutions



10.Our exhibition

2023 We Will Continue To Expand The Market And Take Our New Products

To Visit New Energy Exhibitions In The United States,Germany,Dubai, South Africa, Spain, The United Kingdom, The Netherlands... And Other Countries.

Looking Forward To Meeting You.



10.FAQ

Q1: What if I don't have import experience ?

A1: We have reliable forwarder agent which can ship items to you by sea/air/Express to your doorstep. Any way, we will help you choose the most suitable shipping service.

Q2: How is your technical support?

A2: We provide lifetime online support through Whatsapp/ Skype/ Wechat/ Email. Any problem after delivery, we will offer you video call anytime, our engineer will also go to oversea help our customers if necessary.

Q3: How can I make sure it's a secure transaction ?

A3: Trade Assurance protects online orders when payment is made through Alibaba.com., all of our transaction will go through alibaba platform. As you do the payment, the money will go directly to Alibaba bank account.

After we send you the items and you confirm the detailed information, Alibaba will release us the money.

Q4: Can you get the solar system customized for us ?

A4: Of course, our engineering designers will provide you with the most suitable product and design according to your needs.

Q5: How to become ESG agent?

A5: Contact us through Alibaba, we will give you the best price and look forward to your greetings.

ESG 1U2U 3U Rack BMS 1C Charging 51.2V96v100Ah 200ah Solar Storage Lifepo4 Lithium Iron Battery Pack