



Monofacial

Bifacial

PU610-625SNM101

N-Type

Rated Power 610-625W



N-Type MBB Cell
New circuit design N-type cells, can increase the output power of 10W~20W



Low Light Features
Higher performance under low light environment.



Higher Output Power
Module adopts 156 pcs of 182*182mm half cells, the maximum power can reach 630W.



PID Protection
Ensure the attenuation probability caused by PID phenomenon is minimized.



Harsh Environmental Adaptability
Strict salt spray and ammonia corrosion test by TUV Nord.



Load Capacity
Mechanical load tests including wind load 2400 Pa and snow load 5400 Pa done by TUV Nord.

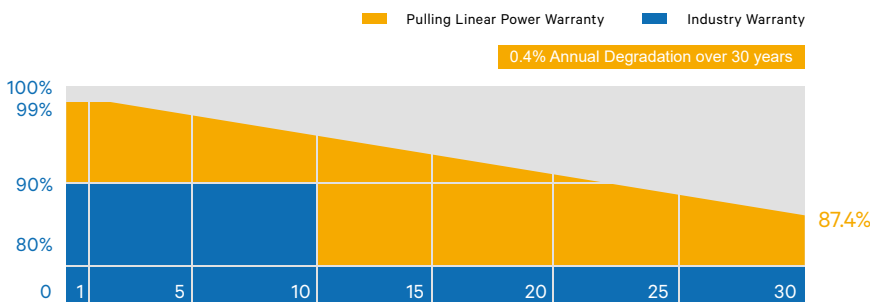

IEC 61215-2: 2016
IEC 61730-2: 2016

SUZHOU PULLING ENERGY CO., LTD

MECHANICAL DIAGRAMS

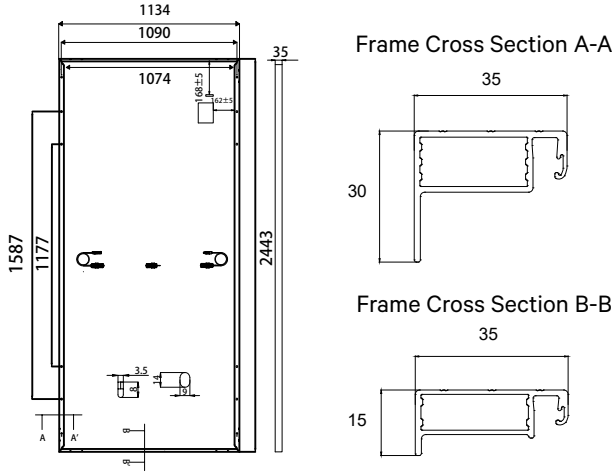

SPECIFICATIONS

Weight	29kg
Dimensions	2443mm*1134mm*35mm
Cell Dimensions	182*182mm
Cell Amount	78*2 pcs
Maximum System Voltage	1500V
Junction Box	IP68
Frame	Aluminum Alloy
Cable	4mm ² , N 300mm/P 300mm or customized length
Connector	MC4 compatible
Application Level	Class A

ELECTRICAL PARAMETERS AT STC

Power	PU610SNM101	PU615SNM101	PU620SNM101	PU625SNM101
Open Circuit Voltage	55.33V	55.48V	55.63V	55.78V
Short Circuit Current	14.09A	14.16A	14.23A	14.30A
Maximum Power Voltage	45.66V	45.76V	45.86V	45.96V
Maximum Power Current	13.36A	13.44A	13.52A	13.60A
Module Efficiency	22.02%	22.20%	22.38%	22.56%

* Under Standard Test Conditions (STC) of irradiance of 1000 W/m², spectrum AM 1.5 and cell temperature of 25°C.

ELECTRICAL PARAMETERS AT NMOT

Power	459W	463W	467W	470W
Open Circuit Voltage	52.56V	52.70V	52.84V	52.98V
Short Circuit Current	11.37A	11.43A	11.48A	11.54A
Maximum Power Voltage	42.38V	42.49V	42.61V	42.72V
Maximum Power Current	10.83A	10.89A	10.95A	11.01A
Module Efficiency	16.57%	16.71%	16.86%	16.97%

* Under Nominal Module Operating Temperature (NMOT), irradiance of 800 W/m², spectrum AM 1.5, ambient temperature 20°C, wind speed 1 m/s.

TEMPERATURE CHARACTERISTICS

NMOT	41±3°C	Temp Coefficient of ISC	+0.046%/°C
Temp Coefficient of VOC	-0.25%/°C	Temp Coefficient of Pmax	-0.30%/°C

PACKING CONFIGURATION

Modules/Pallet	31 Pieces	Modules/40'Container	558 Pieces
Packing Description	17 Pallets, Total=(31+31)x9=558 Pieces		

CHARACTERISTICS

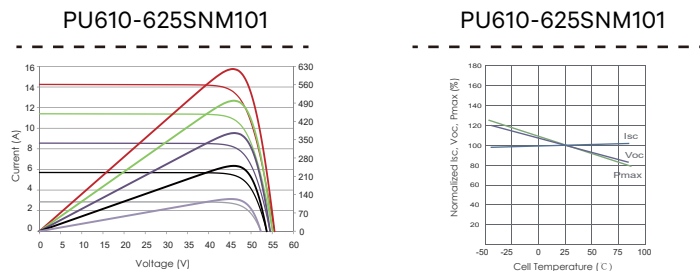

MAXIMUM RATING

Output Tolerance	0~+5W
Operating Temperature	-40°C~+85°C
Wind Load/Snow Load	2400pa/5400pa
Fuse Current	25A

15 YEARS Quality Warranty

30 YEARS Power Warranty