

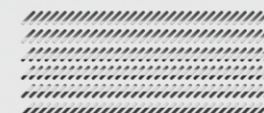

**ENERGY
STORAGE**



**ENERGY
STORAGE**



100kW/230kWh

AIR COOLING ENERGY STORAGE SYSTEM SPECIFICATIONS

ZHEJIANG BENYI NEW ENERGY CO.,LTD.

CHANGJIANG RD, WENZHOU DAQIAO INDUSTRY PARK, BEIBAIXIANG TOWN, YUEQING, WENZHOU CITY, ZHEJIANG PROVINCE, CHINA
TEL: +86-577-5717 7008 FAX: +86-577-5717 7007

✉ info@beny.com

🌐 www.beny.com

♻️ This catalogue has been printed on ecological paper.

© Zhejiang Benyi New Energy Co., Ltd. All rights reserved.

⚠️ If the models and specifications in this product catalogue change due to product updates, we will not provide prior notification.

Importer:xxxxxxx

Address:xxxxxxx



VERSION: 20240201-01

Product Introduction

The 100kW/230kWh air cooling energy storage system adopts an "All-In-One" design concept, with ultra-high integration that combines energy storage batteries, BMS (Battery Management System), PCS (Power Conversion System), fire protection, air conditioning, energy management, and more into a single unit, making it adaptable to various scenarios. This product features a prefabricated cabin design flexible deployment, convenient transportation, and no need for internal wiring and debugging. It responds quickly, boasts high reliability, and offers functions such as peak shaving, power capacity expansion, emergency backup power, grid balancing, capacity management, and multi-level parallel connection.

Application Scenario

It is suitable for industrial and commercial situations with high requirements for grid continuity, and can cover communication energy storage, grid frequency modulation energy storage, wind and solar micro-grid energy storage, large-scale industrial and commercial distributed energy storage, data center energy storage, and photovoltaic power generation business in the new energy field.

Product Features



Standard Design

Modular "All-In-One" integrated single design for ease of transportation, convenient shipping, and straightforward maintenance.



Intelligent and Efficient

Mature energy management strategies and equipment control, intelligent operation and maintenance, remote control to maximize the product's value.



High Safety

Multi-level fire protection system, graded isolation interlocking protection, and a circular air duct design to ensure the safe and stable operation of the product.



Flexible and Easy to Install

Supports multi-level parallel connection, bottom busbar design, maximizing land space utilization.

Specifications and Model Description

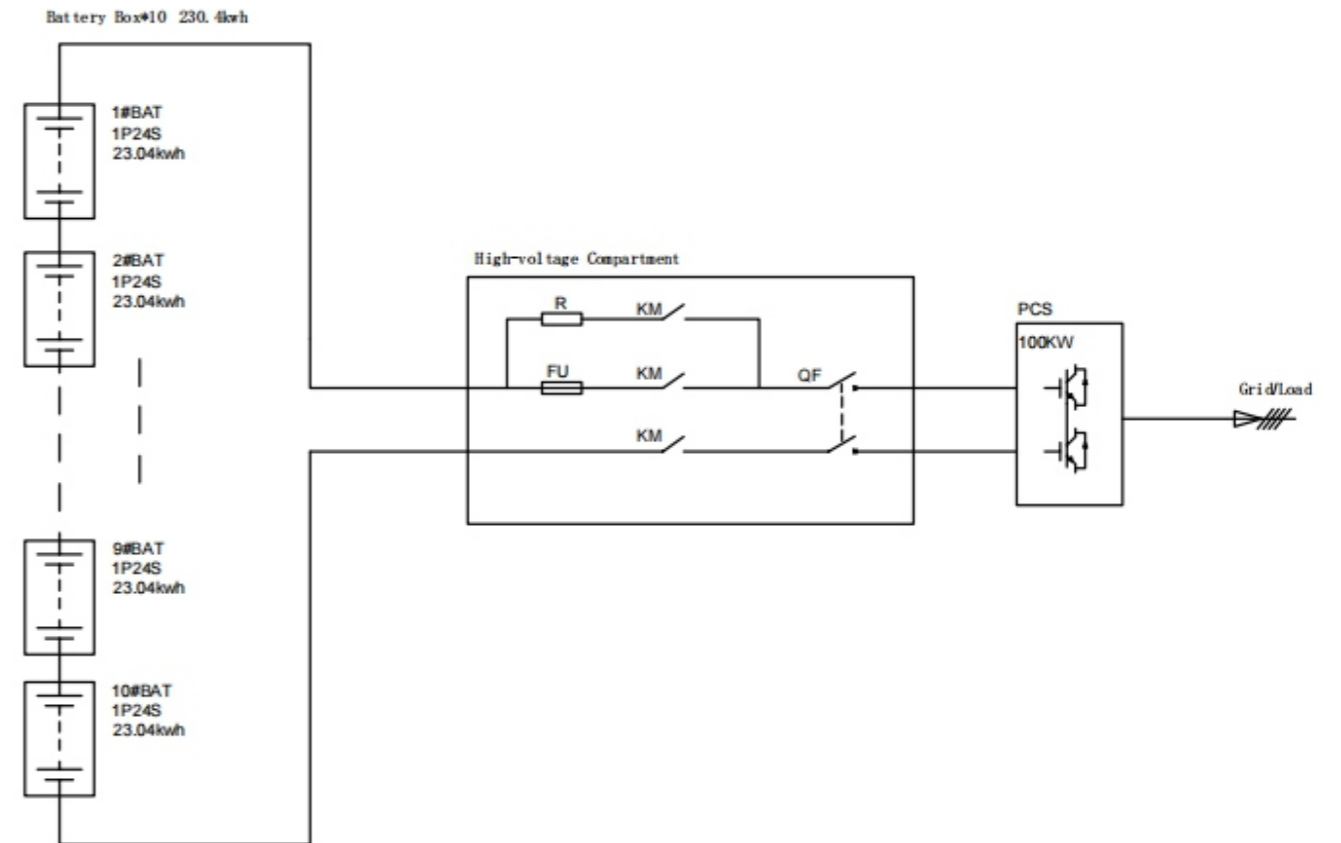

Product Introduction

BYHV-230SAC



AC Parameters

Rated Power	100kW
Rated Voltage	AC380V to 415V
Rated Current	150A
Rated Frequency	50Hz/60Hz
Power Factor	0.99
Output Harmonics	< 3%
Connection Method	3P+N+PE
Isolation Method	Non-isolated

DC Parameters

Battery Type	300Ah, LFP
Battery Grouping Method	1P240S (1P24S*10)
Battery Rated Capacity	230.4kWh
Battery Rated Voltage	768V
Battery Voltage Range	628V to 855V
Rated Charge/Discharge Current	150A
Cycle Life	≥8000 cycles (at 25°C, 0.5C, 80% Depth of Discharge)

System Parameters

System Energy Efficiency	≥90%
Operating Modes	Grid-Tied / Off-Grid
Communication Method	CAN, 485, TCP/IP
Protection Level	IP55
Anti-Corrosion Level	C3
Noise	≤65dB
Fire Protection	Aerosol
Operating Temperature	-29°C to +50°C
Operating Humidity	0% to 95% (no condensation)
Altitude	≤2000m (derating above 2000m)
Cooling Method	Intelligent Air Cooling
Overall Dimensions (WHD)	1130mm*2050mm*1865mm
Weight	Approximately 2.6 tons

Installation Requirements

1. The installation environment should be dry, well-ventilated, free from corrosive substances, free from electromagnetic interference, and with a temperature between -29°C and 50°C.
2. The equipment should be placed on a stable surface and should maintain a certain distance from surrounding objects for heat dissipation.
3. The equipment should have reliable grounding and comply with relevant safety standards.
4. Follow the steps in the product manual or installation manual for installation and wiring.

Maintenance And Care

1. Regularly inspect the operating status of the equipment and perform necessary maintenance, including checking the tightness of terminal connections, the condition of cable equipment connections, and insulation performance. The equipment should be placed on a stable surface and should maintain a certain distance from surrounding objects for heat dissipation.
2. The battery components should be replaced regularly to ensure the normal operation of the equipment.
3. Periodically clean and maintain exhaust vents, such as air conditioning, ensuring cleaning fluids do not enter the equipment.

After-sale Service

1. We provide comprehensive after-sales service, including equipment installation, commissioning, and maintenance. The battery components should be replaced regularly to ensure the normal operation of the equipment.
2. During the equipment warranty period, we will provide free repairs or replacements. After the warranty period, we offer paid repair and maintenance services.
3. After equipment installation, we provide free safety inspections and safety training.

Precautions

1. Before installing the equipment, place it in a dry and well-ventilated environment, avoiding prolonged exposure to humid conditions.
2. Do not place flammable or explosive materials on the equipment.
3. Prohibit illegal operations and modifications on the equipment. If parameter changes are required, please contact the manufacturer or dealer.