

CNFJ series sealed lead acid battery

The CNFJ series is suitable for medium and low depth loop scene applications. The product uses a nanogel electrolyte with a dedicated deep cycle formulation. CNFJ series has high charging efficiency at extremely low charging current, and has excellent resistance to overcharge and overdischarge. This range of products is suitable for photovoltaics, wind power systems and similar cyclic applications.

12 V voltage **120Ah** capacity circular technology **8 years** design life



Complied standards

- IEC61427
- GB/T 22473
- UL1989

TECHNICAL SPECIFICATIONS

Nominal Voltage (V)	12 (6 cells per unit)
Designed Floating Life (25°C)	8 Years
Nominal Capacity (25°C)	120Ah@C ₁₀ Capacitance, 12.0A discharging to be 10.8V
Dimension (mm)	L409mmxW177mmxH225mm
Approx. Weight	36 kg
Terminal Type	Female Copper Insert M8 (torque:6~8N.m)
Internal Resistance	Approx.4.0mΩ (fully charged @ 25°C)
Max. Charge Current	30A
Max. Discharge Current (5S)	960 A
Self Discharge	Approx. 2.5% per month @25°C
Ambient Temperature	Discharge: -25~65°C Charge: -25~60°C Storage: -25~45°C
Float Charge Voltage	14.4 ~ 14.7V @25°C
Equalize and cycle Use Charge Voltage	13.5 ~ 13.8V @25°C
Container Material	ABS (UL94-V0 optional)

BATTERY DIMENSIONS

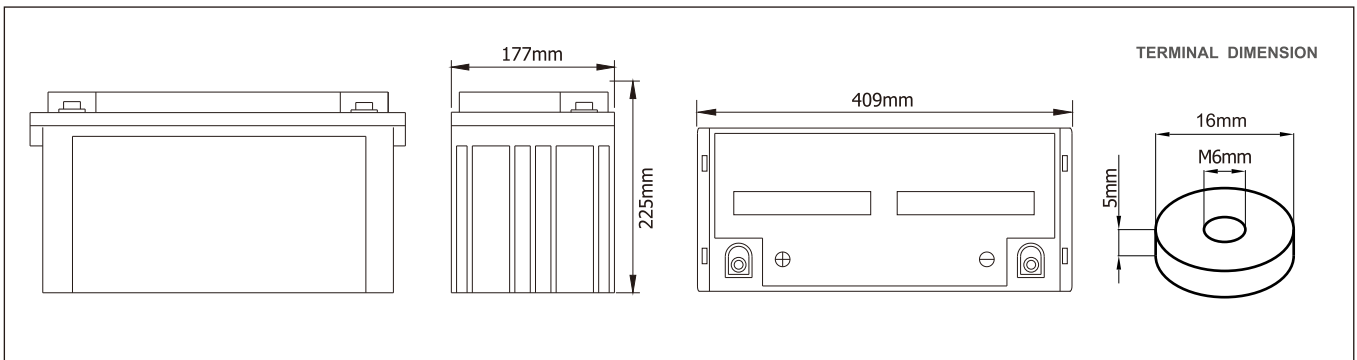

BATTERY DISCHARGE TABLE

F.V/Time	30min	1h	2h	3h	4h	5h	8h	10h	20h
1.70V	124	77.1	45.7	33.2	26.5	22.1	15.0	12.4	6.54
1.75V	120	75.6	44.9	32.7	26.2	21.8	14.8	12.2	6.42
1.80V	115	73.1	43.9	32.0	25.6	21.3	14.5	12.0	6.30
1.85V	108	69.9	42.2	31.0	24.8	20.8	14.2	11.7	6.15

F.V/Time	30min	1h	2h	3h	4h	5h	8h	10h	20h
1.70V	233	146	87.0	63.5	50.9	42.7	29.3	24.3	12.9
1.75V	227	144	86.2	63.1	50.7	42.5	29.1	24.1	12.7
1.80V	219	140	85.1	62.4	50.0	41.8	28.7	23.8	12.6
1.85V	208	136	82.6	60.9	49.0	41.1	28.2	23.4	12.4

Long-term discharge capacity parameters

Capacity	C ₂₄ (Ah)	C ₄₈ (Ah)	C ₇₂ (Ah)	C ₁₀₀ (Ah)	C ₁₂₀ (Ah)
6-CNFJ-120	128	136	139	145	150
Final Voltage	1.85V				

Solar & Wind applications parameters settings

Over voltage disconnect:	2.45±0.01V/cell @ 25°C
Regulation/equalize voltage:	2.40±0.01V/cell @ 25°C
Array roconnection voltage:	2.25±0.005V/cell @ 25°C
Float voltage setting:	2.27±0.005V/cell @ 25°C
Low voltage alarm voltage:	1.95±0.005V/cell @ 25°C
Low voltage disconnect:	1.90±0.005V/cell @ 25°C
Load reconnect voltage:	2.09±0.01V/cell @ 25°C
Temp. compensate coefficient:	-3~-5mV/cell/°C

CHARACTERISTICS

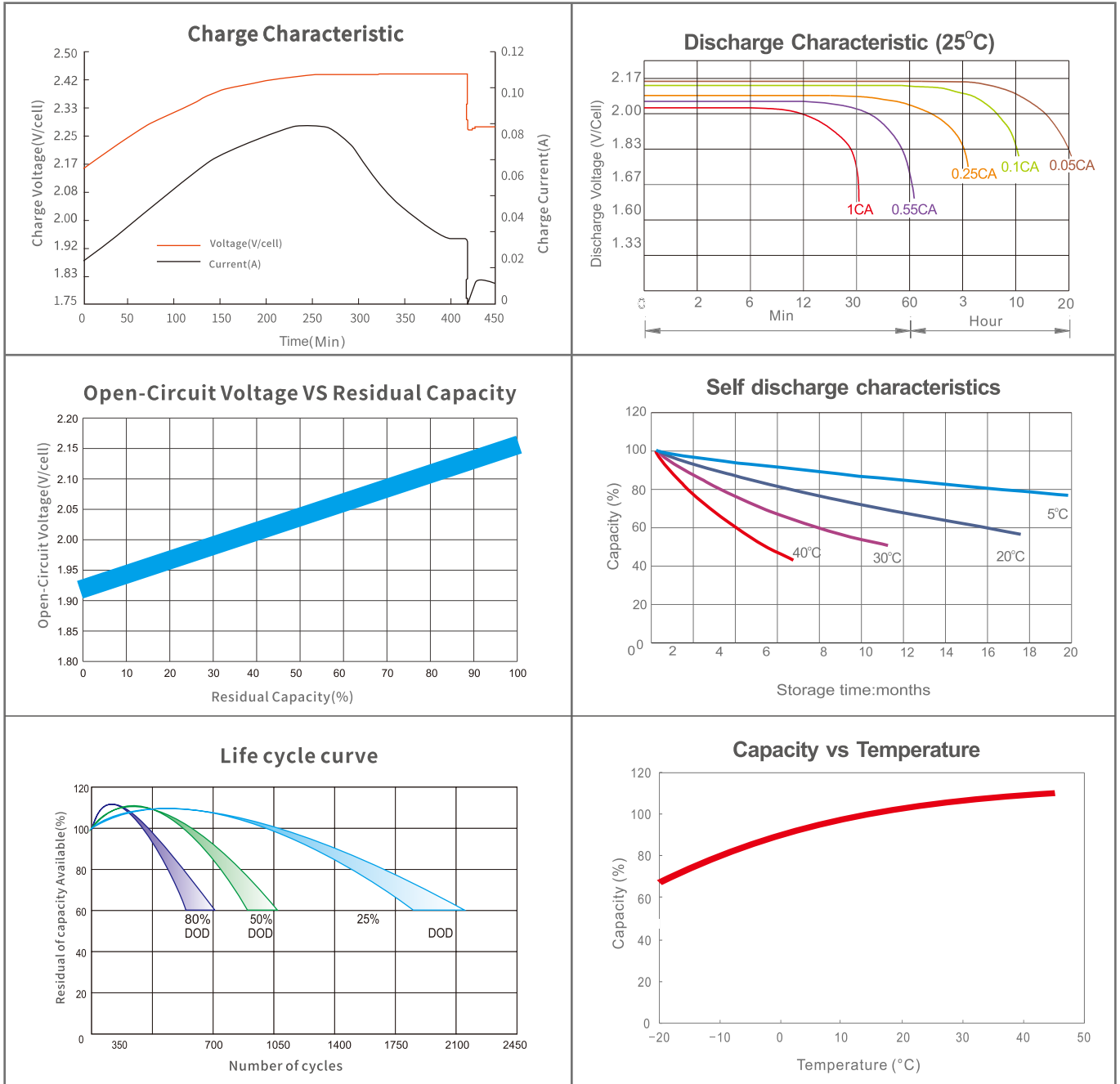

FINAL VOLTAGE SETTINGS RECOMMENDED ACCORDING TO THE DISCHARGE CURRENT

Discharge Current I (A)	$I < 0.08C$	$0.08C \leq I < 0.2C$	$0.2C \leq I < 0.6C$	$0.6C \leq I < 1.0C$	$I \geq 1.0C$
Final of Voltage	$\geq 1.85V_{pc}$	$\geq 1.80V_{pc}$	$\geq 1.75V_{pc}$	$\geq 1.70V_{pc}$	$\geq 1.60V_{pc}$

CONTACT US:

Company: Zhejiang Chisen Battery Co., Ltd

Address: Room 3305, Building 2, Wealth Financial Center, Shangcheng District, Hangzhou, Zhejiang

Website: <https://www.chisen.cn>

Email: sales@chisen.cn

chisenbattery@gmail.com

Facebook: <https://www.facebook.com/chisenbattery>

LinkedIn: <https://linkedin.com/company/chisen>

VK: <https://vk.com/chisenbattery>

Note: All above information shall be changed without prior notice, CHISEN reserves the right to explain and update

