

S P E C I F I C A T I O N S H E E T

Ultra-Light High-Power Solar Panels

for Solar-Powered UAV Applications



Flexible · Ultra-Light · High-Efficiency · Damage-Resistant

Rev. 2026-03 — For professional use only

1. Product Overview

This product is a flexible, ultra-lightweight solar panel based on Silicon Heterojunction (SHJ) technology with advanced silver-wire interconnection.

It is specifically designed for solar-powered UAVs, offering:

- High power-to-weight ratio
- Excellent mechanical flexibility
- Superior damage tolerance
- Reliable performance under extreme environmental conditions

The panel is particularly suitable for high-altitude, long-endurance platforms (HAPS) and lightweight aircraft systems.

2. Technical Specifications

Parameter	Value / Range
Solar Cell Technology	Silicon Heterojunction (SHJ)
Solar Cell Efficiency	≥ 25 %
Solar Cell Thickness	< 100 μm
Interconnection Technology	Flexible silver-wire (no welding) — 40× larger current collection area vs. conventional ribbon Interconnection technology
Panel Dimensions	Customizable
Panel Thickness	1.0 – 1.5 mm
Panel Areal Density	500 – 600 g/m ²
Specific Power Density	300 – 400 W _p /kg

3. Typical Electrical Characteristics

(Custom specifications available on request — values measured under STC: 1 000 W/m², AM 1.5, 25 °C)

Parameter	Typical Value
Peak Power P_{max} (+ 3 %)	178 W
Maximum Power Voltage V_{mp}	24.4 V
Maximum Power Current I_{mp}	7.3 A
Open-Circuit Voltage V_{on}	29.2 V
Short-Circuit Current I_{sn}	7.8 A
Panel Length	1 062 mm
Panel Width	888 mm
Panel Thickness	1.5 mm

Parameter	Typical Value
Panel Weight	0.56 kg
Specific Power Density	318 W/kg
Operating Temperature Range	- 85 °C to + 85 °C
Power Temperature Coefficient	- 0.27 %/°C
Current Temperature Coefficient	+ 0.04 %/°C
Voltage Temperature Coefficient	- 0.26 %/°C

4. Ultra-Light, High-Power Solar Panels Gallery



5. Core Technology Advantages

5.1 High-Efficiency SHJ Solar Cells

The panels integrate Silicon Heterojunction (SHJ) solar cells with a conversion efficiency of $\geq 25\%$ under standard test conditions ($1\,000\text{ W/m}^2$). SHJ technology delivers excellent low-irradiance performance, typically generating more than 10% additional energy compared with conventional cell technologies under overcast or high-altitude diffuse-light conditions.

5.2 Flexible Silver-Wire Interconnection

Solar cells within the panel are interconnected via a proprietary flexible silver-wire structure that significantly enhances mechanical reliability and provides superior resistance to cell cracking and mechanical impact.

- **No-weld contact:** Forms an ohmic contact with the TCO layer on the cell surface; no welding required.
- **40× current area:** Provides 40× larger current-conduction area compared with conventional ribbon welding interconnection, enabling current to bypass damaged regions even in the event of micro-cracks — thereby minimizing power loss.

6. Customized Solutions

We offer fully custom-engineered solar panel systems tailored to your UAV platform. All key parameters — wing geometry, system voltage, connector layout — are adapted for maximum aerodynamic and electrical integration efficiency.

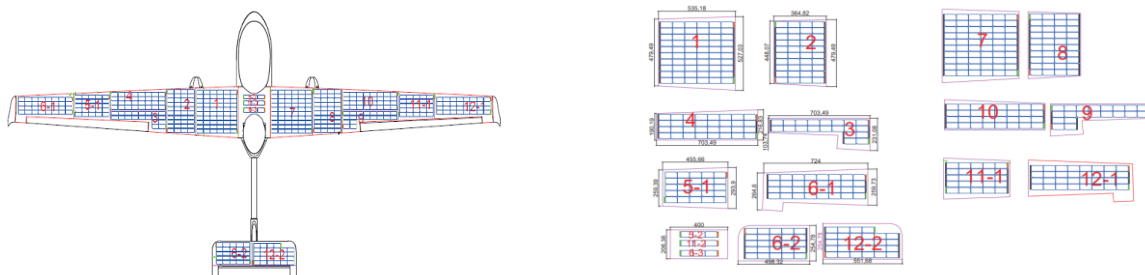

7. Application Scenarios

- Fixed-wing UAVs
- High-Altitude Platform Systems (HAPS)
- Near-space platforms

8. Typical Projects

Wingspan 4 meters

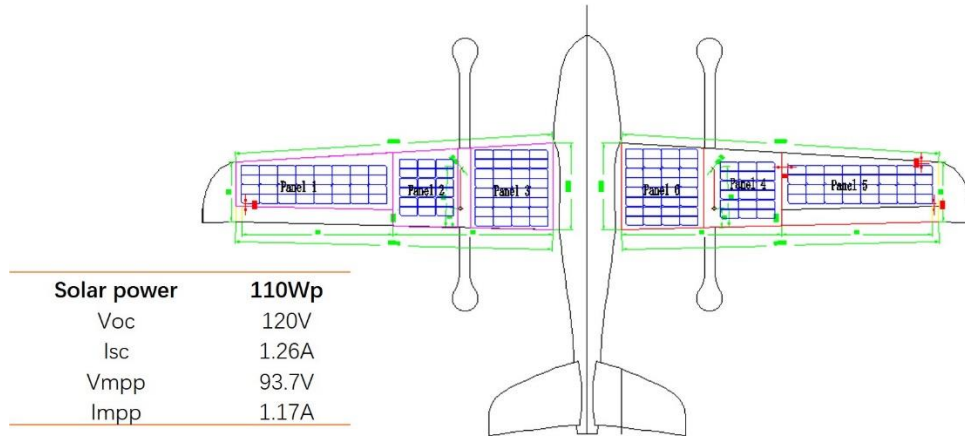

Wingspan 4.4 meters

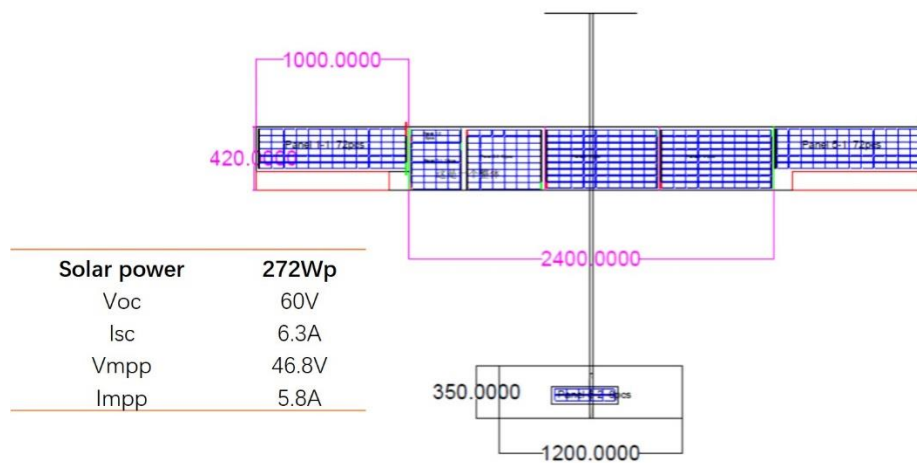

Wingspan 6 meters

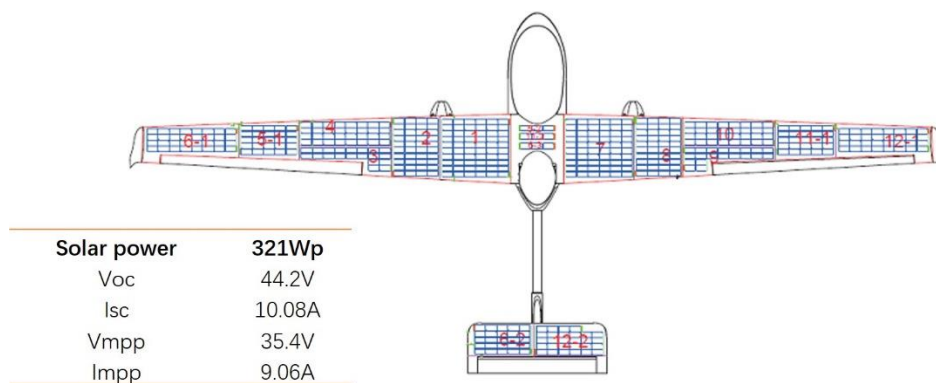

Wingspan 6 meters



Solar power	395Wp
Voc	58.1V
Isc	8.28A
Vmpp	48.6V
Impp	8.12A

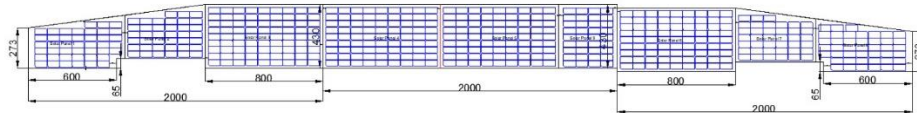

Wingspan 8 meters



Solar power	429Wp
Voc	115.3V
Isc	4.68A
Vmpp	99.5V
Impp	4.31A

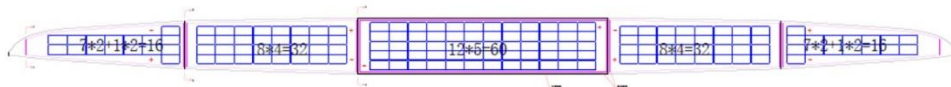

Wingspan 26 meters

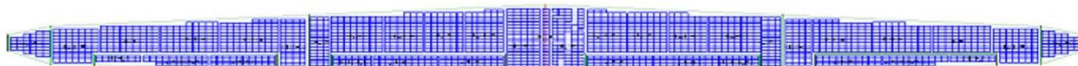

Solar power	6053Wp
Voc	115.3V
Isc	70.5A
Vmpp	93.8V
Impp	64.5A

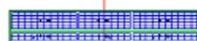

9. Contact Information

Email: info@gh-newenergy.com
Phone: +86 158 2197 3158