



Specification

Voltage Per Unit	2V(single cell)
Capacity	1500Ah@10hr-rate to 1.80V per cell @25°C
Weight	Approx. 110.0 Kg
Max. Discharge Current	4500 A (5 sec)
Internal Resistance	Approx. 0.23 mΩ
Operating Temperature Range	Discharge: -40°C~70°C Charge: 0°C~50°C Storage: -20°C~60°C
Optimal Operating Temperature Range	25°C ± 5°C
Float charging Voltage	2.25 to 2.3 VDC/unit Average at 25°C
Maximum Charging Current	300 A
Cycle Service	2.37 to 2.40 VDC/unit Average at 25°C
Self Discharge	Self-discharge ratio less than 2% per month at 25°C. Please charge batteries before using.
Terminal	Thread insert & Bolt (F10-M8)
Container Material	A.B.S. (UL94-HB), and UL94-V0 is optional



ISO9001:2000 Certificate

Dimensions

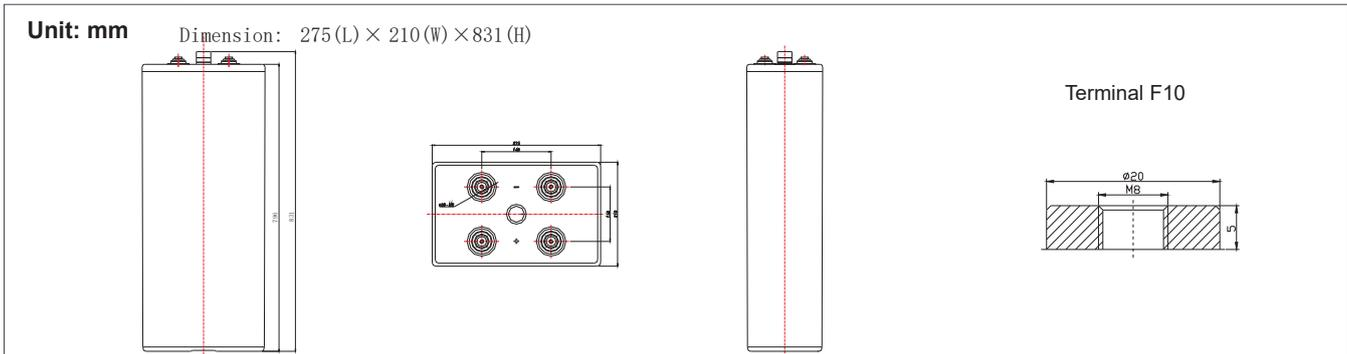

Constant Current Discharge Characteristics : A(25°C)

F.V/ Time	30min	1h	2h	3h	4h	5h	6h	8h	10h	20h
1.90	738.0	585.0	412.5	312.8	256.5	221.6	199.5	155.7	133.5	70.09
1.87	825.0	645.0	442.5	331.7	270.8	233.2	211.5	163.0	139.5	73.24
1.83	945.0	720.0	480.0	353.6	285.0	243.2	219.0	170.2	145.5	76.39
1.80	1050	780.0	498.0	363.8	290.7	249.0	225.0	174.6	150.0	78.75
1.75	1170	835.5	520.5	378.3	295.5	255.0	229.5	177.5	153.0	80.33
1.70	1290	862.5	535.5	385.6	300.7	258.0	232.5	179.0	154.5	81.11
1.65	1331	916.5	553.5	396.0	305.0	261.0	235.5	180.4	156.0	81.90
1.60	1388	948.0	574.5	412.5	313.5	265.5	238.5	181.9	157.5	82.69

Constant Power Discharge Characteristics : W(25°C)

F.V/ Time	30min	1h	2h	3h	4h	5h	6h	8h	10h	20h
1.90	1413	1123	797.5	606.0	502.0	436.5	394.5	311.4	272.1	142.8
1.87	1554	1220	845.7	634.7	529.1	457.5	417.0	324.5	283.7	149.0
1.83	1741	1330	900.0	667.8	554.8	475.5	430.5	336.1	293.9	154.3
1.80	1902	1419	930.1	682.9	565.3	486.0	441.0	343.4	301.2	158.1
1.75	2064	1482	960.3	704.0	572.9	498.0	448.5	347.7	305.6	160.4
1.70	2213	1497	984.4	716.1	581.9	502.5	453.0	350.7	308.5	161.9
1.65	2251	1563	1012	731.1	589.4	507.0	457.5	353.6	309.9	162.7
1.60	2278	1612	1036	755.3	604.5	511.5	460.5	355.0	311.4	163.5

All mentioned values are average values.

Effect of temperature on long term float life

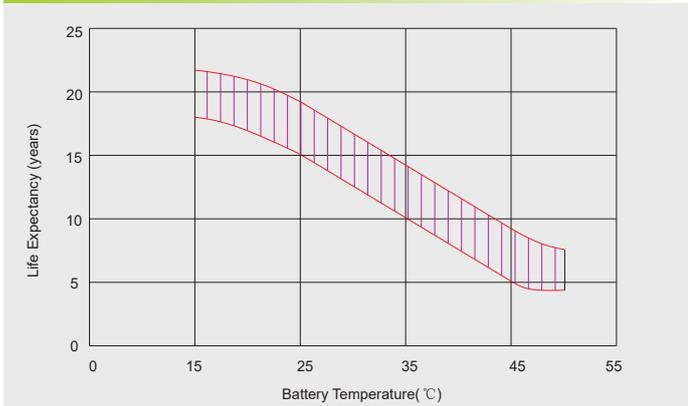

Life characteristics of cyclic use

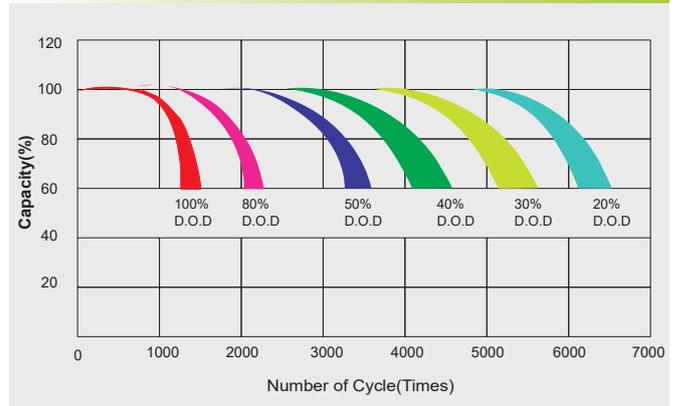

Charge characteristic Curve for cyclic use

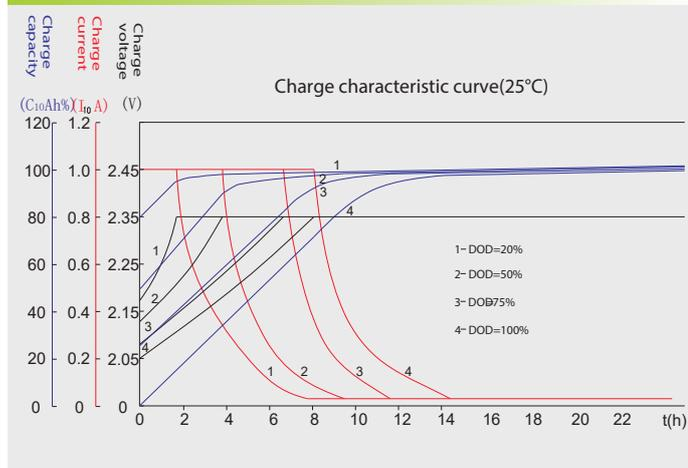

Discharge characteristic Curve



Long time discharge capacity for solar/wind application

Model	Capacity					
	C24 (Ah)	C48 (Ah)	C72 (Ah)	C100 (Ah)	C120 (Ah)	C240 (Ah)
OPzV2-1500	1639	1830	1845	1870	1908	1941

F.V=1.85VPC

Capacity factors vs temperature (OPzV series)

Temperature	-30°C	-20°C	-10°C	0°C	10°C	20°C	25°C	30°C	40°C	45°C	50°C
Capacity	60%	75%	83%	89%	92%	99%	100%	103%	105%	107%	109%

Discharge Current VS. Final Voltage

Discharge current	Final voltage (V)
$I_{dis} \leq 0.1I_{10}$	1.90
$0.1I_{10} < I_{dis} \leq I_{10}$	1.85
$I_{10} < I_{dis} \leq 4I_{10}$	1.80
$4I_{10} < I_{dis} \leq 6I_{10}$	1.75
$6I_{10} < I_{dis} \leq 10I_{10}$	1.70
$I_{dis} > 15I_{10}$	1.60

Charge the batteries at least once every one year, if they are stored at 25°C.

Charging Method:

Constant Voltage	-0.2Cx2h+2.35~2.40V, 24h, Max. Current 0.2CA
Constant Current	-0.2Cx2h+0.1CAx12h

Maintenance & Cautions

Float Service:

- ※ Every month, recommend inspection every battery voltage.
- ※ Every three months, recommend equalization charge for one time.

Equalization charge method:

Discharge: 40~50% rate capacity discharge.

Charge: Max. current 0.2CA, constant voltage 2.35-2.40V/Cell charge 24h.

- ※ Effect of temperature on float charge voltage: -3mV/°C/Cell.
- ※ Service life will be directly affected by the number of discharge

cycles, depth of discharge, ambient temperature and charging method.