

BASIC STRUCTURE 产品基本结构

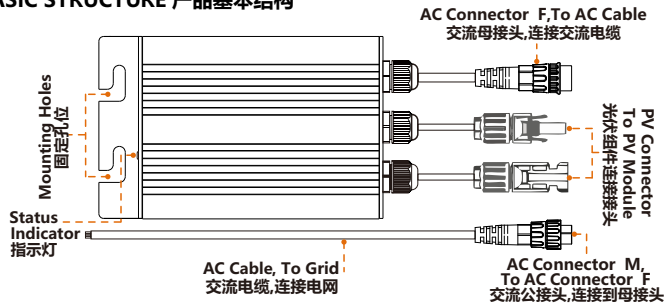

PACKING LIST 包装清单



Grid Tie Micro Inverter GMI Series User Manual

并网微型逆变器 GMI系列使用手册

DANGER! 有电危险!

Read user manual before operating this equipment. Failure to do so can result in serious injury, property damage, and/or electrical shock.
操作本设备前请阅读使用手册。不这样做可能导致严重伤害、财产损失或触电危险。



- Use photovoltaic panel(s) ONLY connect to this equipment. 本设备仅能用于连接光伏组件。
- This equipment is ON-GRID Microinverter. To make it work properly, it must be connected to the power grid correctly, and the power grid is working properly. When the power grid stopped working, it will also stop generating. 本设备是并网发电设备，它必须连接到电网且电网工作正常时才能正常发电，当电网停电时，本设备也将停止发电。
- Do NOT exceed PV panel(s) voltage over the inverter max input voltage. 在使用前，请确保光伏组件的开路电压VOC和工作电压VMP符合本设备的输入电压和工作电压范围。
- Do NOT exceed PV panel(s) power over the inverter max input power. 在使用前，请确保光伏组件的最大输出功率没有超过本设备的最大输入功率。
- DC voltage sources are pass through this equipment. Each circuit must be individually disconnected before servicing. 光伏组件的直流电会通过本设备，维修或拆卸前必须单独断开每个电路。
- Do NOT cover other items on this equipment. 请不要在本设备上覆盖任何其他物体。
- Do NOT remove the lid. Servicing must be performed by qualified service personnel. 请不要打开外壳，维修本设备需要由专业人士进行。
- When PV array is exposed to light, it supplies DC voltage to this equipment. 当光伏组件连接到本设备并暴露在阳光下时将向本设备供应直流电，请注意安全。
- Install away from direct sunlight and direct rain exposure. 请不要将本设备安装在阳光能够直射或雨雪可能覆盖的地方（如两片组件之间的缝隙部位应避免）。

AC Cable 交流电缆说明

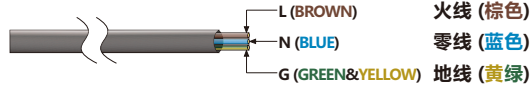

PARAMETER TABLE 参数表

Product Series 产品系列 Model 产品型号	GMI120-180 L Series (GMI120-180 L 系列)		
	GMI120L	GMI150L	GMI180L
Input Data (DC, PV) 光伏输入 (DC)			
Number of Input MC4 Connector 输入端MC4接头数量	1 set (组)		
MPPT Voltage Range 最大功率点跟踪范围	12.5V-25V		
Operation Voltage Range 工作电压范围	10.8V-30V		
Maximum Input Voltage 最大直流输入电压	30V		
Startup Voltage 启动电压	10.8V		
Maximum Input Power 最大直流输入功率	120W	150W	180W
Maximum Input Current 最大直流输入电流	7.5A	9.37A	11.25A
Output Data 交流输出 (AC)			
Single-Phase Grid Type 单相电网类型	120V / 230V		
Rated Output Power 额定输出功率	100W	130W	150W
Maximum Output Power 最大输出功率	110W	140W	160W
Nominal Output Current 额定交流电流	120V : 0.83A / 230V : 0.43A	120V : 1.08A / 230V : 0.56A	120V : 1.25A / 230V : 0.65A
Nominal Output Voltage 额定交流电压	120VAC / 230VAC		
Default Output Voltage Range 输出电压范围	@120VAC : 80V-160V / @230VAC : 180V-280V		
Nominal Output Frequency 额定交流频率	50Hz / 60Hz		
Default Output Frequency Range 输出频率范围	@50Hz : 47.5Hz-52.5Hz / @60Hz : 57.5Hz-62.5Hz		
Power Factor 输出功率因数	>0.99		
Efficiency 效率			
Peak Efficiency 最高转换效率	92.5%		
CEC Weighted Efficiency CEC 加权效率	@120VAC : 90.5% / @230VAC : 91.5%		
Nominal MPPT Efficiency MPPT 跟踪效率	99.9%		
Night Power Consumption 夜间损耗	<700mW		
Mechanical Data 机械数据			
Operating Ambient Temperature Range 工作环境温度	-40°C to +65°C		
Storage Temperature Range 存储环境温度	-40°C to +85°C		
Dimensions (W x H x D) 尺寸 (长 x 宽 x 高)	35mm x 76mm x 203mm		
Weight 重量	0.4kg		
Waterproof Grade 防护等级	IP55		
Cooling Mode 冷却方式	Natural Convection - No Fans 自然冷却-无风扇		
Other Features 其它特征			
Transformer Design 隔离特性	High Frequency Transformers, Galvanically Isolated 高频变压器隔离		
Integrated Ground 综合接地	Equipment ground is provided by the PE in the AC cable. No additional ground is required. 交流电缆线中的PE端是设备的接地线，无其他接地端口。		
Protection Functions 保护方式	Isolated Island, Voltage, Frequency, Temperature, Current etc. 孤岛保护、电压保护、频率保护、温度保护、电流保护等。		

Specifications subject to change without notice

参数如有变更恕不另行通知

LED DISPLAY 指示灯说明

1. Green light steady 绿灯常亮 = Microinverter in generating. 微型逆变器正常发电中。

2. Red flash 红灯慢闪 = Microinverter in waiting. 微型逆变器等待中。

3. Red light steady 红灯常亮 =

- Island protection. 孤岛保护。
- Over-temperature protection. 过热保护。
- Over / low AC voltage protection. AC电压过低/过高保护。
- Over / low DC voltage protection. DC电压过低/过高保护。
- Over / low AC frequency protection. AC频率过低/过高保护。
- Fault. 硬件故障。

INSTALLATION PROCEDURES 安装步骤说明

*Prior to installing the Microinverters, Please verify that the utility voltage at the point of common grid connection matches the voltage rating on the Microinverter label.

*在安装微型逆变器前，请检查电网电压和光伏组件电压是否和微型逆变器外壳上所贴标签上标注的输入和输出电压等级符合，如不符合请停止继续安装，否则有可能损坏微型逆变器。

Step 1 (第1步) - Attaching the Microinverters to the Racking. a. Mark the location of the Microinverter on the rack, with respect to the PV module junction box or any other obstructions. b. Mount one Microinverter at each of these locations using hardware recommended by your module racking vendor.

(安装微型逆变器到支架上：a. 依据与光伏组件接线盒或其它障碍物距离等标记出微型逆变器在支架上的位置。b. 使用支架供应商推荐的工具把每台微型逆变器固定到指定位置。)

Step 2 (第2步) - Connecting the Microinverter AC cable and connecting to AC bus cable (L-BROWN, N-BLUE, G-GREEN&YELLOW) one by one, Please do NOT exceed the Maximum current of AC bus cable.

(依次连接所有微型逆变器的交流电缆并连接 (火线-棕色, 零线-蓝色, 地线-黄绿色) 到交流主电缆上。请注意：每条支路连接的数量不能超过最大电流数。)

Step 3 (第3步) - Connecting Microinverters to the PV Module, Please do NOT exceed PV panel(s) VOC over inverter max. input voltage. (连接光伏组件至微型逆变器。请注意：光伏组件电压不能超过逆变器最大输入电压。)

Step 4 (第4步) - Install the AC Branch Circuit Junction Box, Wire the conductors of the AC bus cable. Connect the AC branch circuit junction box to the point of utility-grid Interconnection.

(安装交流支路防水接线盒和连接交流总线至接线盒，并连接交流支路接线盒至电网连接点。)

Step 5 (第5步) - Double check all Microinverters, connectors and cables are correctly and well connected.

(再次检查所有微型逆变器、接头以及电缆是否正确且良好连接。)

Step 6 (第6步) - Turn ON the AC circuit breaker on each AC branch circuit of Microinverter.

(依次闭合各支路交流断路器。)

Step 7 (第7步) - Turn ON the main AC circuit breaker of utility-grid. Your system will start producing power after a 3sec safety delay period. (闭合并网主断路器，您的发电系统将在等待3秒钟后开始发电。)

WIRING SCHEMATIC 接线示意图

GMI Series-120/230VAC @ Single Phase 120/230V (安装在单相120或230V电网)

Micro Inverter Voltage 逆变器电压	120/230VAC
Grid Voltage 电网电压	120/230V
Grid Type 电网类型	Single Phase 单相

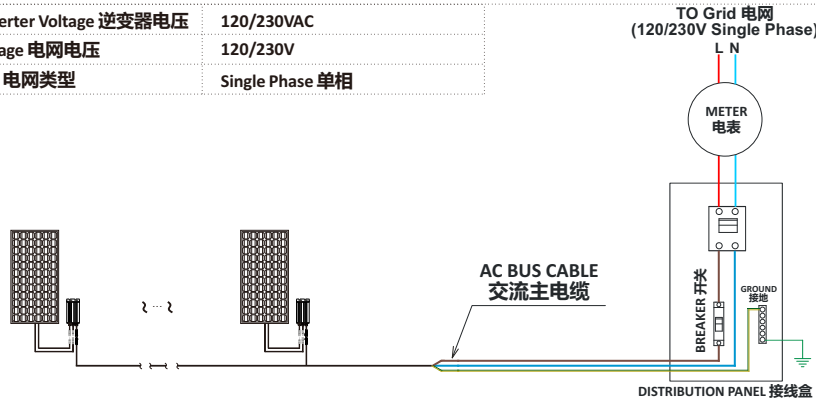

GMI Series-230VAC @ 2-Phase 208/240V (230V逆变器安装在2相208/240V电网)

Micro Inverter Voltage 逆变器电压	230VAC
Grid Voltage 电网电压	208/240V(1-Phase 120V 单相120V)
Grid Type 电网类型	Dual Phase 2相

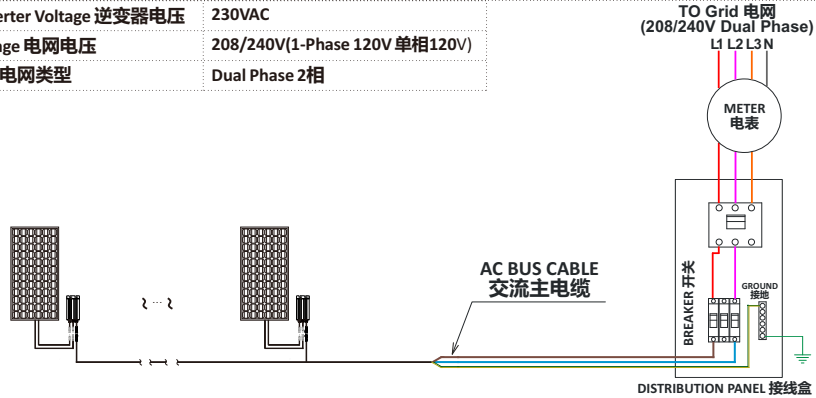

GMI Series-120VAC @ 3-Phase 208/240V (120V逆变器安装在3相208/240V电网)

Micro Inverter Voltage 逆变器电压	120VAC
Grid Voltage 电网电压	208/240V(1-Phase 120V 单相120V)
Grid Type 电网类型	Triple Phase 三相

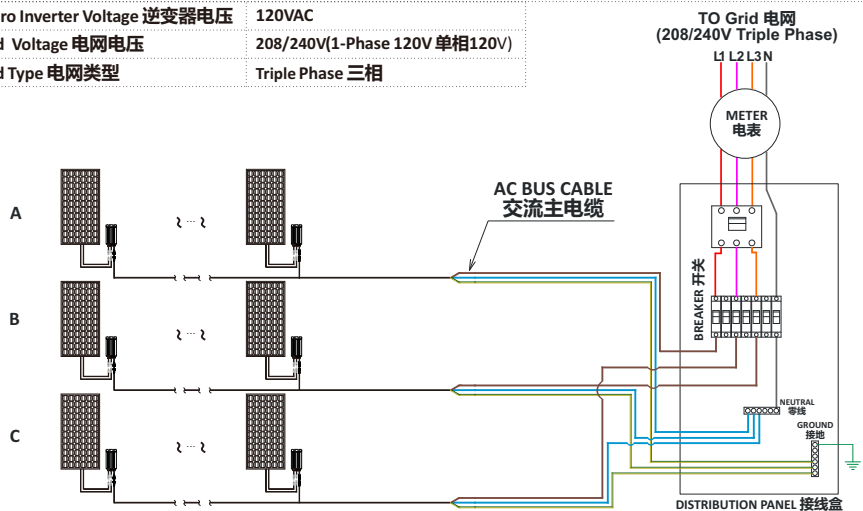

GMI Series-230VAC @ 3-Phase 380V (230V逆变器安装在3相380V电网)

Micro Inverter Voltage 逆变器电压	230VAC
Grid Voltage 电网电压	380V(1-Phase 230V 单相230V)
Grid Type 电网类型	Triple Phase 三相

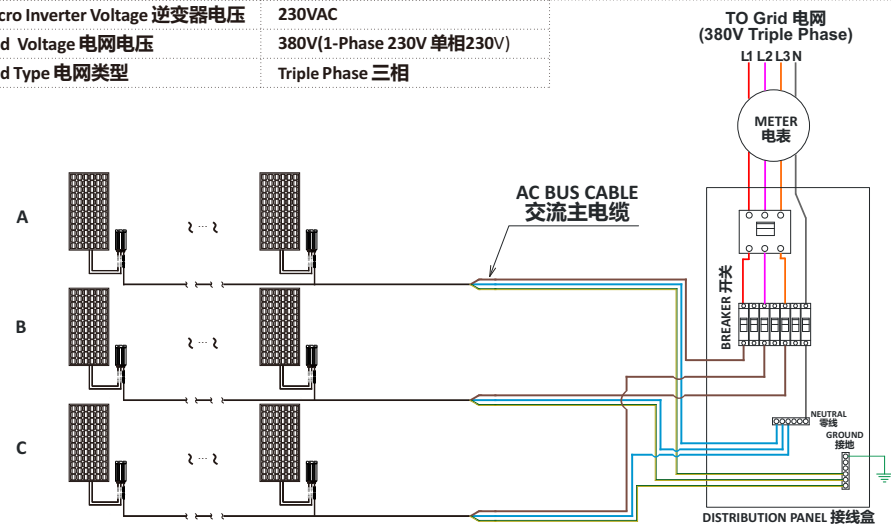

GMI Series-230VAC @ 3-Phase 208/240V (230V逆变器安装在3相208/240V电网)

Micro Inverter Voltage 逆变器电压	230VAC
Grid Voltage 电网电压	208/240V(1-Phase 120V 单相120V)
Grid Type 电网类型	Triple Phase 三相

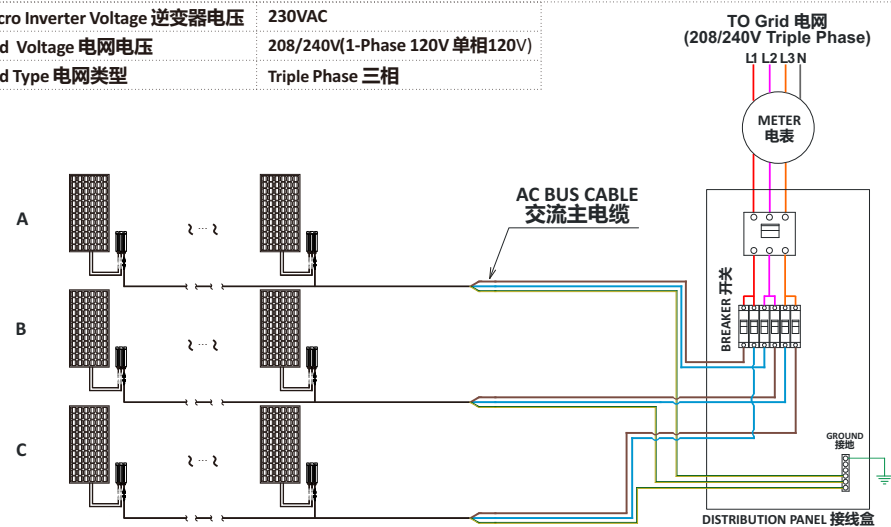

INSTALLATION SCHEMATIC 系统安装示意图

