

## JPC SERIES LEAD CARBON BATTERY

### JPC12-150

#### APPLICATIONS

- Solar / wind energy and other new energy storage
- Hybrid vehicles, electric bicycles and other new energy vehicles
- Other backup or cycle purposes

#### GENERAL FEATURES

- Lead-carbon composite negative plate, both capacitance and battery characteristics
- Long cycle life, excellent deep cycle discharge ability
- Excellent charge acceptance ability
- Optimized capability of instant high-current discharging
- Strong high and low temperature performance
- Precision sealing technology

#### DIMENSION AND WEIGHT

	JPC12-150
Length	407mm
Width	170mm
Height	220mm
Total Height	223mm
Weight	Approx. 45.0kg

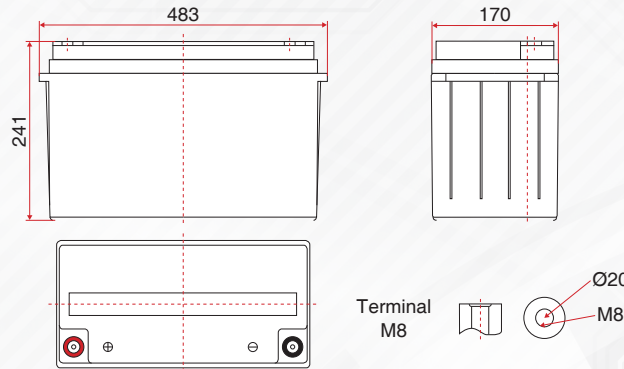

#### PRODUCT SPECIFICATIONS

ITEM	JPC12-150
Nominal voltage	12V
Nominal capacity	150Ah
Design life	15 years
Terminal	M8
Approx. weight	Approx 45.0kg (99.57lbs)
Container material	ABS
Rated capacity	<b>150Ah</b> 10 Hour rate (15.0A to 10.8V) <b>122Ah</b> 3 Hour rate (40.7A to 10.8V) <b>99.2Ah</b> 1 Hour rate (99.2A to 10.5V)
Internal resistance	Full charged at 25°C: 3.3 mΩ
Max discharge current	1800A (5s)
Operating temperature	Discharge: -40 ~ 60°C (-40 ~ 140°F) Charge: -20 ~ 50°C (-4 ~ 122°F) Storage: -20 ~ 50°C (-4 ~ 122°F)
Charge method (25°C)	Charge current: Max. 45A; recom. 15.0 ~ 22.5A Float charge: 13.5 - 13.8V, recom. 13.5V (-18mV/°C) Equalize charge: 13.8 - 14.1V, recom. 14.1V (-24mV/°C) Cycle charge: 14.4 - 15.0V, recom. 14.4V (-30mV/°C)
Self discharge	3% of capacity declined per month at 25°C



Constant current discharge characteristics unit: A (25°C, 77°F)

VOLTAGE	JPC12-150									
F.V TIME	5min	15min	30min	1h	2h	3h	5h	8h	10h	20h
1.60V	539	290	176	102	58.5	42.5	28.5	18.7	15.8	8.27
1.65V	523	281	173	101	58.2	42.0	28.2	18.6	15.6	8.23
1.70V	502	275	170	101	57.8	41.4	27.9	18.4	15.5	8.18
1.75V	462	266	169	99.2	56.9	41.0	27.6	18.3	15.3	8.15
1.80V	414	248	161	96.7	55.8	40.7	26.9	18.1	15.0	8.11
1.85V	369	221	147	89.5	53.0	38.3	25.5	17.4	14.7	7.97

Constant power discharge characteristics unit: W/cell (25°C, 77°F)

VOLTAGE	JPC12-150									
F.V TIME	5min	15min	30min	1h	2h	3h	5h	8h	10h	20h
1.60V	904	510	319	193	111	80.8	54.0	36.4	30.3	16.4
1.65V	869	501	316	191	110	79.7	53.7	36.1	30.0	16.3
1.70V	865	495	316	190	110	79.3	53.3	35.9	29.7	16.2
1.75V	807	492	314	188	109	78.8	53.0	35.6	29.4	16.1
1.80V	741	465	307	187	109	78.5	52.4	35.3	29.1	16.1
1.85V	661	416	281	174	104	74.7	50.0	34.1	28.6	15.9

Disclaimer: Manufacturers have the right to self-modify the parameters of the product updates, please keep in touch with manufacturers to obtain the latest information

Discharge characteristics

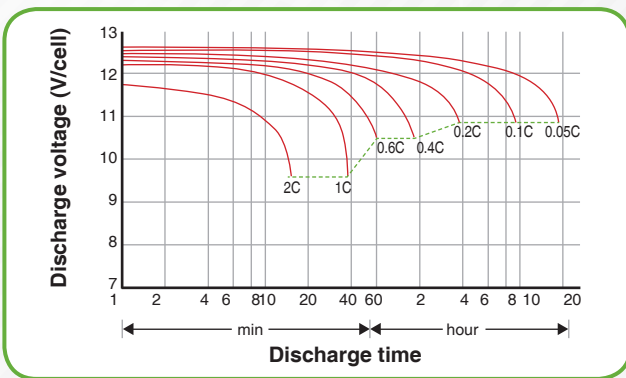

Charging characteristics

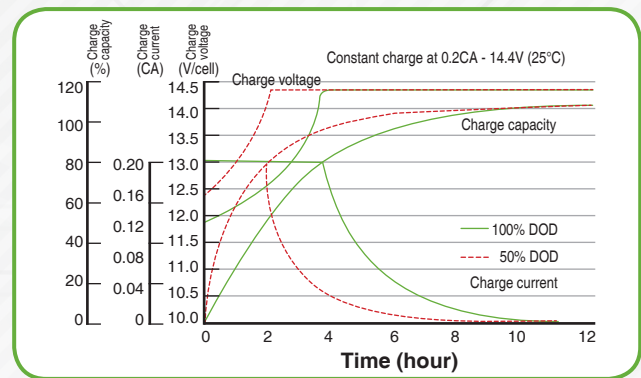

The effect of temperature on capacity

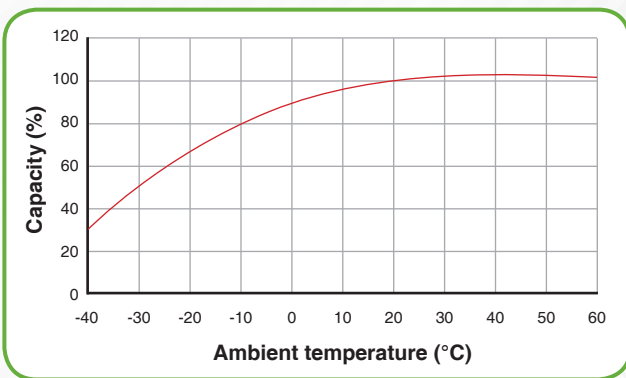

The effect of discharge depth on cycle life

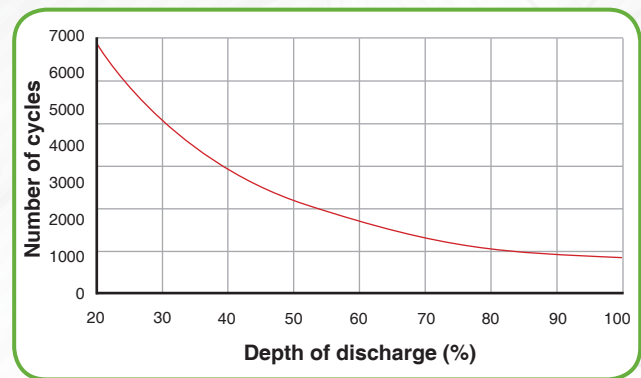

Curves of self-discharge

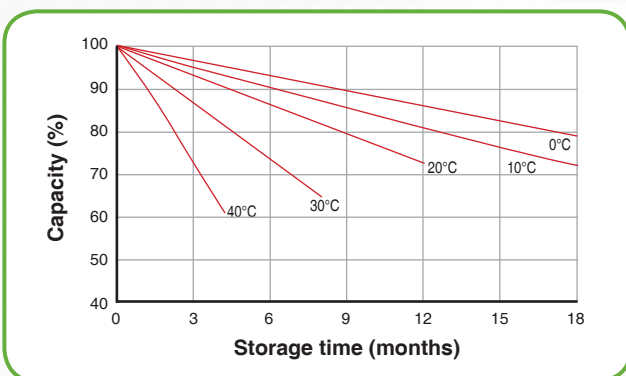

Curves of open circuit voltage vs. capacity

