

RECOM - SILLIA

French Manufacturer of Photovoltaic Modules

Series 60P: 265 to 285 Wp "Plus"

Series 60P: 250 to 270 Wp

Series 60M: 265 to 285 Wp "Plus"

Series 60M: 295 to 305 Wp "Plus"

Series 72P: 315 to 335 Wp "Plus"

Series 72P: 300 to 325 Wp

Series 72M: 355 to 380 Wp "Plus"

Series 72M: 315 to 335 Wp

Let the sun work for you



Quality

Certification ISO 9001
Holder of the mark "Certisolis"



Components

Certified suppliers
Strict criteria for the selection of cells (Europe and Asia)
Anti reflective glass, MC4 Type connectors
Silver white and full black modules



Product

IEC 61215 and 61730 parts I and II
Load resistance -5400 pa
Hail impact resistance class 4
Max voltage 1500V (optional)



Warranty

Product: 12 years
1 year: Poly (98,5%),
Poly "Plus"/Mono (97,5%), Mono "Plus" (97%)
10 years at 90%, 25 years at 80% (linear)



Environment

Controlled carbon footprint
PV-Cycle member
OHSAS 18001 and ISO 14001



Environment

Class 250-380Wp -0/+4,99Wp
Poly or Mono cells
60 or 72 cells per module

This document has been written according to the EN 50380-2003 standard



Production video



Series 60M: Monocrystalline modules 60 cells

| Electrical Performance STC ⁽¹⁾ | | 60M295 | 60M300 | 60M305 |
|---|-----|--------|--------|--------|
| P_{MPP} | [W] | 295 | 300 | 305 |
| Module Efficiency | [%] | 17,95 | 18,25 | 18,56 |
| V_{MPP} | [V] | 31,86 | 32,04 | 32,21 |
| I_{MPP} | [A] | 9,26 | 9,37 | 9,48 |
| V_{OC} | [V] | 39,05 | 39,23 | 39,42 |
| I_{CC} | [A] | 9,69 | 9,78 | 9,86 |
| Electrical Performance NOCT ⁽²⁾ | | 60M295 | 60M300 | 60M305 |
| P_{MPP} | [W] | 215 | 219 | 223 |
| V_{MPP} | [V] | 29,09 | 29,25 | 29,41 |
| I_{MPP} | [A] | 7,41 | 7,50 | 7,58 |
| V_{OC} | [V] | 36,04 | 36,21 | 36,39 |
| I_{CC} | [A] | 7,81 | 7,88 | 7,95 |
| Electrical Performance Low Irradiation ⁽³⁾ | | 60M295 | 60M300 | 60M305 |
| P_{MPP} | [W] | 56,6 | 57,5 | 58,5 |

Tolerance measurements may vary to +/-2.5%

Classification type: 0 / + 5Wc or customized

(1) Values corrected according to standardized test conditions STC: solar irradiance of 1000W/m²; AM 1.5; cell temperature 25°C.

(2) Values corrected according to test conditions NOCT: solar irradiance of 800 W / m²; AM 1.5, NOCT cell temperature.

(3) Corrected values according to low irradiation test conditions: solar irradiance of 200 W / m²; AM 1.5; cell temperature 25°C.

Given the continuous evolution of our products, these values are indicative and subject to modifications without prior information.

| Thermal coefficients | |
|---------------------------------|---------------|
| Coeff. / I_{CC} | + 0,04 % / °K |
| Coeff. / V_{OC} | - 0,31 % / °K |
| Coeff. / P_{MPP} | - 0,41 % / °K |
| NOCT: 45°C | |

| Connection conditions | |
|---|-------------------------------|
| Protection class II, IP 65 | Maximum Voltage: 1000V |
| Operating temperature: -40°C / +85°C | |
| Reverse current max: 15 A | |
| Fuse series: 15 A | |



*refer also to the installation instructions

Technical data and dimensions

Frame: Aluminium anodized
Front side: Tempered glass (EN12150)
Backsheet: PET synthetic film
Weight of the module: 18 kg

Junction box: IP65, 3 bypass diodes
Cells: Monocrystalline silicon 6 "
Connectors: MC4 Type

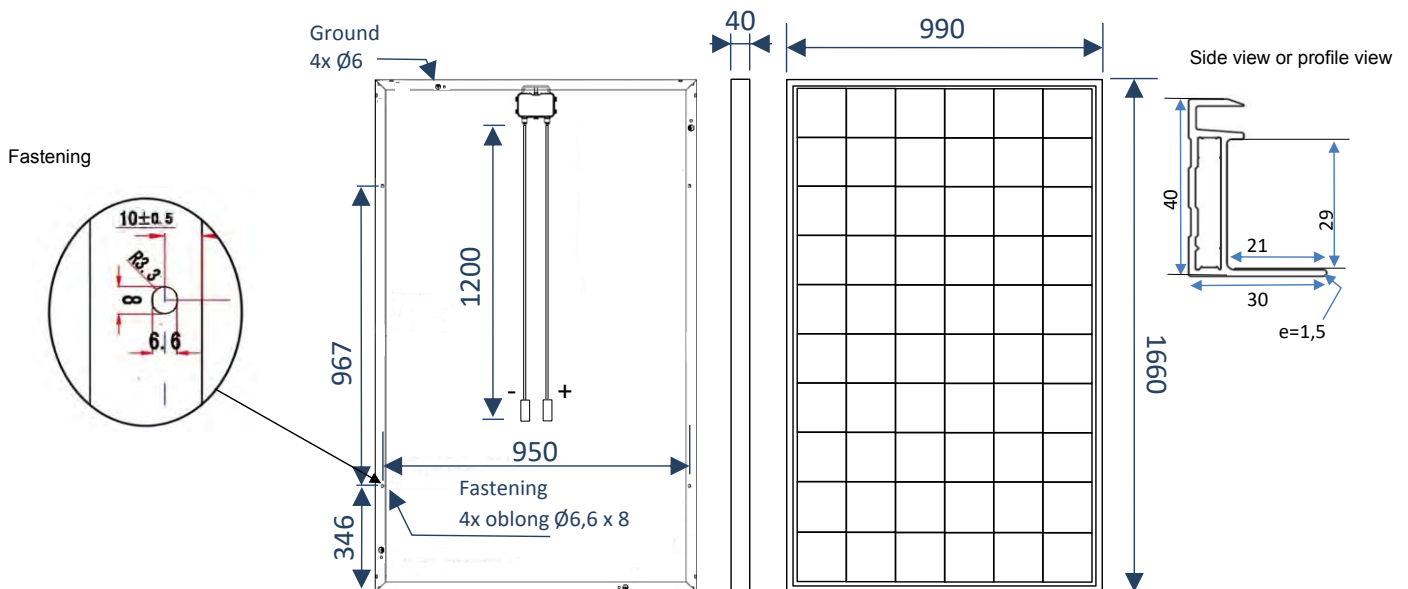

Dimensions in mm
 Solar panel orientation: portrait or landscape*

dimensional tolerance +/- 1 mm

Please select upon placing an order

- | | | |
|---------------------------------|--|---|
| Color Backsheet / Frame: | <input type="checkbox"/> White / Aluminum | <input type="checkbox"/> Black / Black |
| Connectors: | <input type="checkbox"/> MC4 compatible (standard) | <input type="checkbox"/> Multicontact MC4 |
| Type of Glass: | <input type="checkbox"/> Anti-reflective 3,2mm | <input type="checkbox"/> Near airport use, thickness 4 mm (1) |

(1) Module weight: 20kg