

SERIE NOGAL

IPS310W

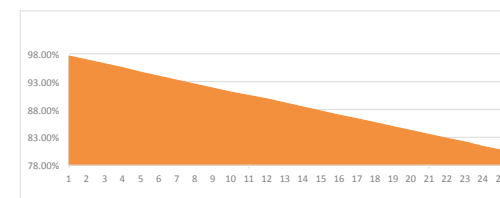
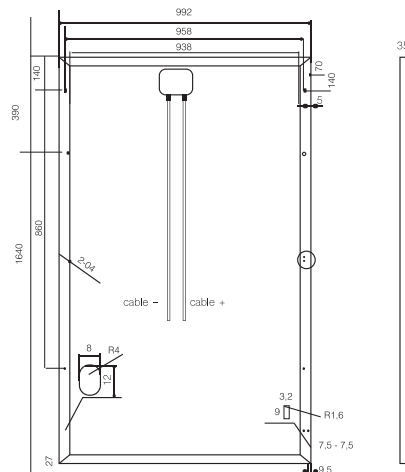
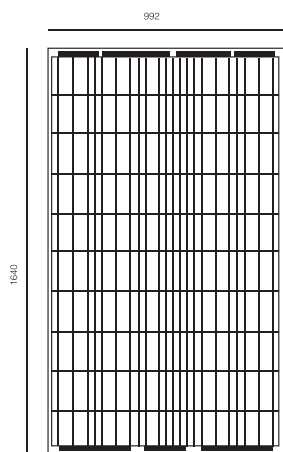
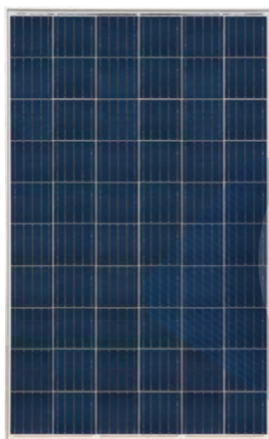

WARRANTY

12 - Year product warranty
 25 - Years of performance

Max. Power (W)	310 W
Max Power Voltaje	37,76V
Max Power Current	8,21 A
Open Circuit Voltaje (Voc)	44,81V
Short Circuit Currente (Isc)	8,79 A
Cell Efficiency	18,05%
Model Efficiency	15,98%
Tolerance (%)	0~+5
NOCT	45°C +/- 2°C
Temperature Coefficient	
Temperature Coefficient Isc (%/°C)	+ 0,05
Temperature Coefficient Voc (%/°C)	- 0,32
Temperature Coefficient W (%/°C)	- 0,41

MECHANICAL DATA	Polycrystalline
Number of cell	6*12
Size	1956*992*40
Front Glass Thickness	3.2
Surface Maximum Load Capacity	5400Pa
Allowable Hail Load	23m/s , 7.53g
Weight Per Piece (Kg)	22.5
Junction Box Type	Protection clas IP67, 3 diodes
Cable & Connector Type	900mm/4mm ² ; MC4

Certificates	IEC 61215, IEC 61730
--------------	----------------------