

The rechargeable batteries are lead-lead dioxide systems. The dilute sulfuric acid electrolyte is absorbed by separators and plates and thus immobilized. Should the battery be accidentally overcharged producing hydrogen and oxygen, special one way valves allow the gases to escape thus avoiding excessive pressure build-up. Otherwise, the battery is completely sealed and is, therefore, maintenance-free, leak proof and usable in any position.

Battery Construction

Component	Positive plate	Negative plate	Container	Cover	Safety valve	Terminal	Separator	Electrolyte
Raw material	Lead dioxide	Lead	ABS	ABS	Rubber	Copper	Fiberglass	Sulfuric acid

General Feature

- Absorbent Glass Mat(AGM) technology for efficient gas recombination of up to 99% and freedom from electrolyte maintenance or water adding.
- Not restricted for air transport-complies with IATA/ICAO Special Provision A67.
- UL-recognized component.
- Can be mounted in any orientation.
- Computer designed lead, calcium tin alloy grid for high power density.
- Long service life, float or cyclic applications.
- Maintenance-free operation.
- Low self discharge.

SPECIFICATION

Nominal voltage 12V
 Number of cell 6
 Length(mm/inch) 522/20.55
 Width(mm/inch) 238/9.37
 Height(mm/inch) 218/8.58
 Total Height(mm/inch) 240/9.45
 Approx. Weight(kg/lbs) 55.5/122.3

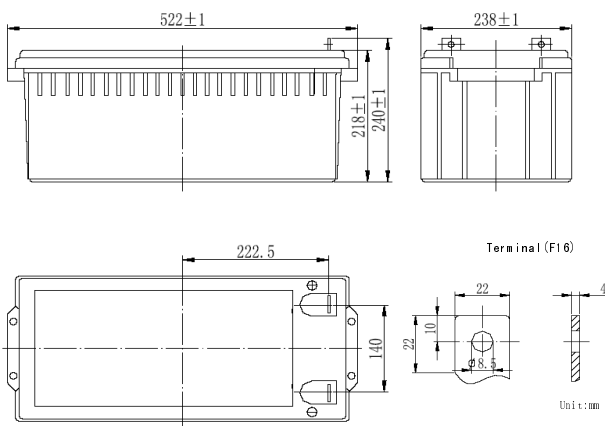

Performance Characteristics

Capacity 77°F(25°C)	20 hour rate (9.3A、10.8V)	186Ah
	10 hour rate (18A、10.5V)	180Ah
	5 hour rate (32A、10.5V)	160Ah
	1 hour rate (115A、9.6V)	115Ah
Internal Resistance	Full charged Battery77°F(25°C): 4.0mΩ	
Capacity affected by Temperature (20 hour rate)	104° F(40°C)	102%
	77° F(25°C)	100%
	32° F(10°C)	85%
	5° F(-15°C)	65%
Self-Discharge 68°F(20°C)	Capacity after 3 month storage	90%
	Capacity after 6 month storage	80%
	Capacity after 12month storage	60%
Max. discharge current77°F(25°C): 950A(5S)		
Charge (Constant Voltage)	Float: 13.6~13.8 V/77° F(25°C)	
	Cycle:14.4~14.7 V/77°F(25°C) Max. Current: 45A	

Discharge Constant Current (Amperes at 77° F25 °C)

End Point Volts/Cell	5min	10min	15min	30min	1h	3h	5h	10h	20h
1.60V		395	315	195	115	48.5	33.5	18.2	9.55
1.65V		372	295	188	113	47.8	33.0	18.2	9.50
1.70V		349	275	181	111	47.0	32.5	18.1	9.45
1.75V		325	253	178	109	46.2	32.0	18.0	9.30
1.80V		300	230	170	106	45.2	31.4	17.8	9.20

Discharge Constant Power (watts at 77° F 25 °C)

End Point Volts/Cell	5min	10min	15min	30min	45min	1h	2h	3h	5h
1.60V		630	510	337	241	223	123	87.7	60.5
1.65V		605	492	324	236	219	121	86.5	60.2
1.70V		579	477	312	231	214	118	85.3	59.7
1.75V		550	461	299	227	210	115	84.1	59.4
1.80V		520	425	282	222	205	117	83.2	58.7

(Note)The above characteristics data are average values obtained Within three charge/discharge cycles not the minimum values.

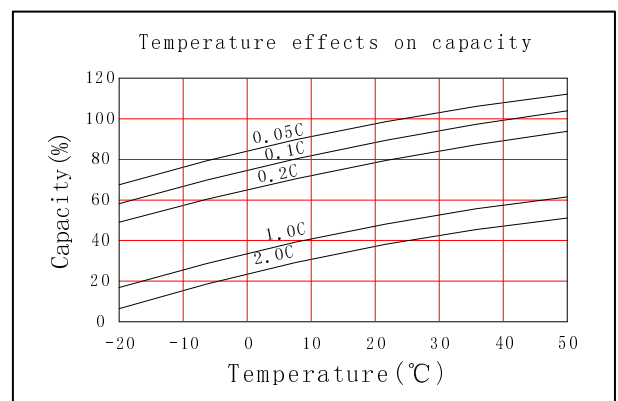
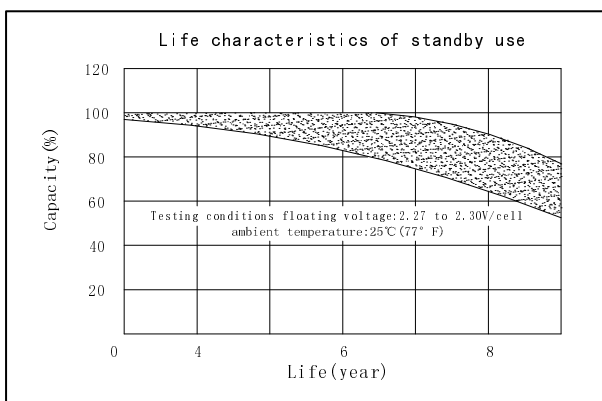
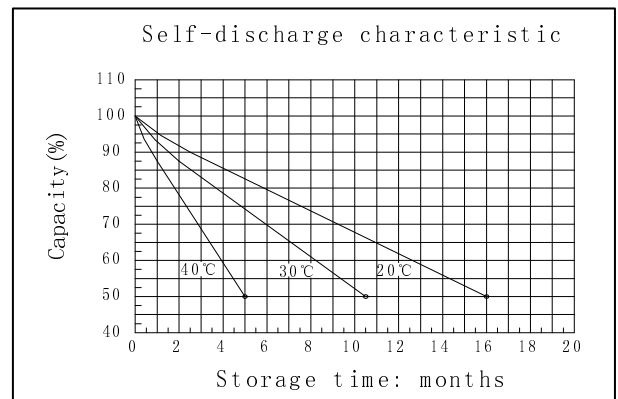
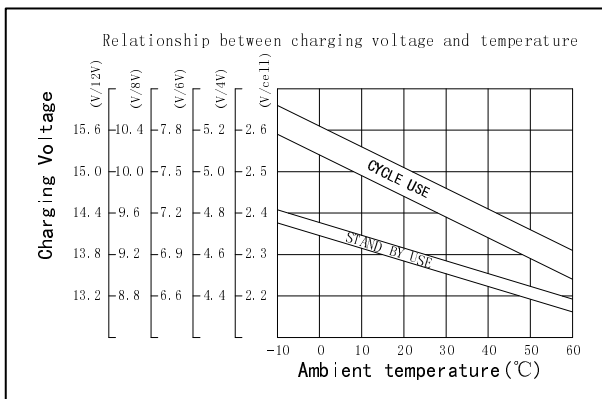
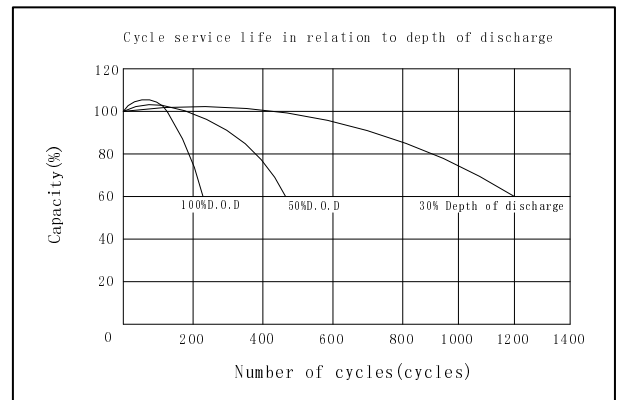
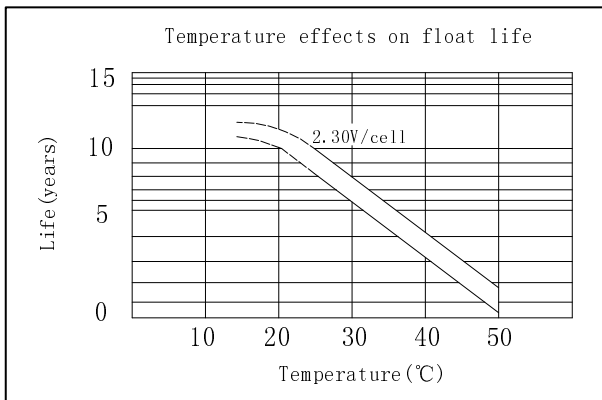
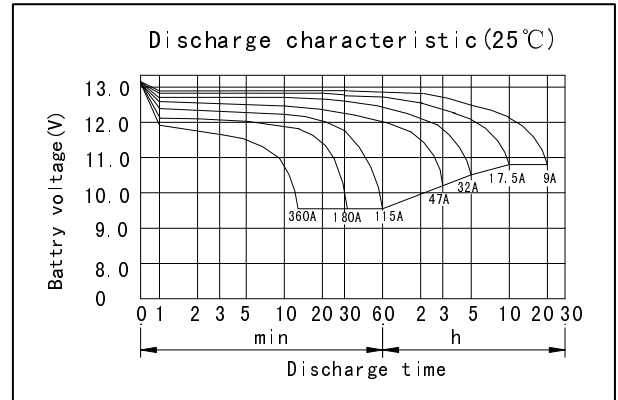
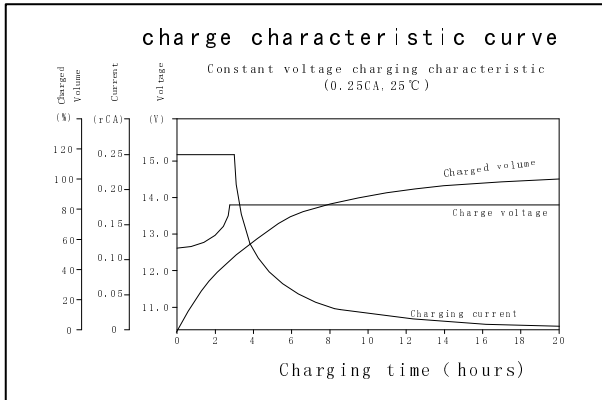

GREAT POWER BATTERY TECHNOLOGY CO.,LTD
 Address: Longguan 1st Road, LongHua Town, BaoAn District, Shenzhen, China.
 TEL: 86-755-2900 8403 Fax: 86-755-3386 3366
 Email: info@greatpowerbattery.com Http:// www.greatpowerbattery.com