

## K13/30T

Dati tecnici	K 13/30T
Camera di lavoro (mm) Shredding chamber (mm)	1258x850
Lame da 30 mm (n.) 30 mm blades (no.)	17
Potenza (kW) Power (kW)	22
Tensione (V) Voltage (V)	220/400/460
Peso (kg) Weight (kg)	4400

# Dati Tecnici/Technical Data

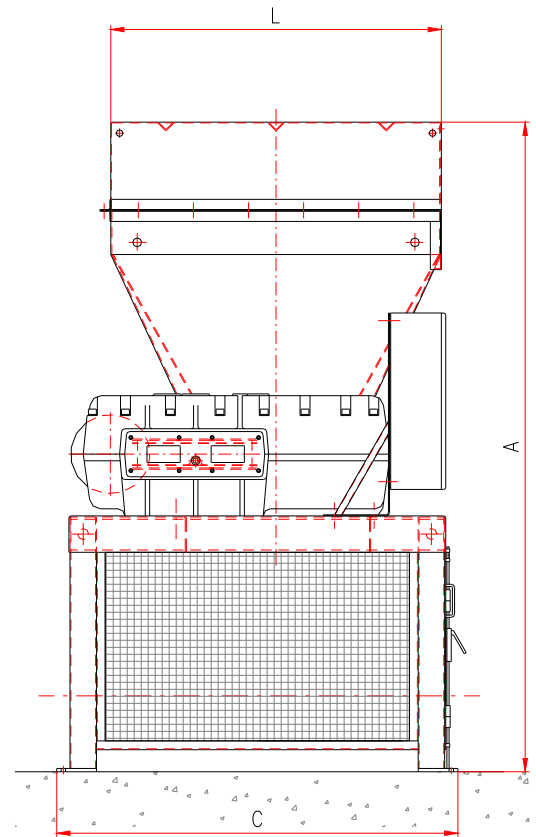
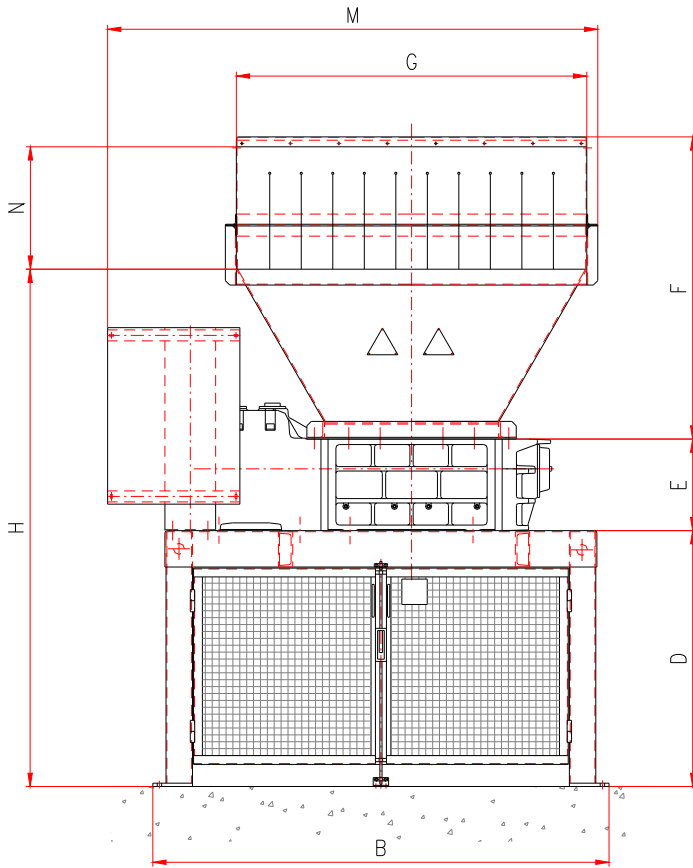

## Esempi di materiali trattati / Some applications:

Legno  
Wood



2500 ÷ 3500 kg/h

Rifiuti solidi urbani  
Urban waste



1500 ÷ 3000 kg/h

## K13/30T

	K13/30T
A	2945
B	2420
C	1820
D	1160
E	415
F	1370
G	2090
H	2345
L	1500
M	2700
N	555

CAT1013 Rev. A.04/15

## SatrindTech S.r.l.

Via Monfalcone, 122 - 20010 Arluno (MI) - Italy

Tel. (+39) 02 90376683

Fax (+39) 02 90376721

info@satrindtech.com

www.satrindtech.com

