

The Republic Machine Horizontal Series Single Shaft Shredder is most effective in the processing of Long Profile Plastic & Wood Parts (PP, HDPE, PVC Composite Lumber, Vinyl Siding, Window & Door Frame Profile, Long Sheet Extrusions) etc.. A long and customizable vibratory conveyor keeps material in movement while our aggressively knurled feed roll assembly meters the profile into the cutting action of the rotor. Full function PLC controls provide all the necessary settings required to run any application. The Horizontal Series Single Shaft Shredder(s) accommodate aggressive throughputs with a 15" Diameter "Hawksbill" Rotor and 25" cutting chamber widths. This series of shredders are powered by 40-125 HP electric motors with rotor speeds in excess of 350 RPM. Sophisticated PLC Control and Digital Readout Displays provide all the necessary settings required to run difficult industry applications.

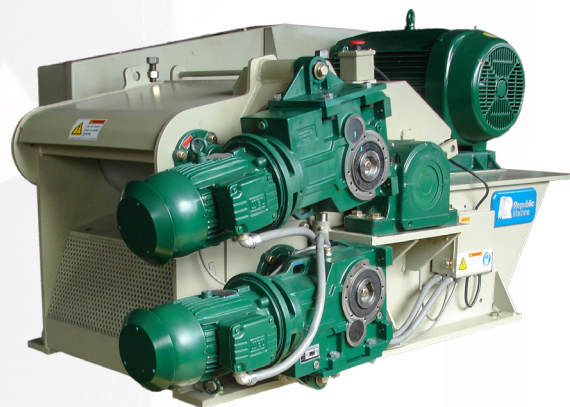

Standard Features

- Solid One-Piece Forged Rotor Limited Lifetime Warranty
- Oversized Outboard Pillow Block Bearings
- Indexable Hawksbill Cutters
- PLC Control System
- Direct V-Belt Drive
- Case Hardened Counterknives
- Self-Cleaning non-contaminating Rotor Seals
- Driven Feedroll Assembly
 - Knurled Solid One-Piece Rolls
 - Timed to Maximize Production Output
- Pneumatic, Gravity & Conveyor Discharge
- Removable Rear Compartment Access Covers

Specifications	25
Rotor Diameter	15"
Rotor Motor Size	50 - 75 HP
Rotor Speed	1350 - 400 RPM
Cutters (1- 2 Rows) Hawksbill	18 - 36
Feed Rolls	Driven and Knurled for Measured and Aggressive Feeding
Infeed Opening (WxH)	25" x 5"
Infeed Conveyor	Vibratory Conveyor
Weight Approx. (tons)	3
Throughput (estimated)	400 - 4,000
Voltage	460V / 3Ph / 60Hz

Horizontal Eagle

Technical Specifications

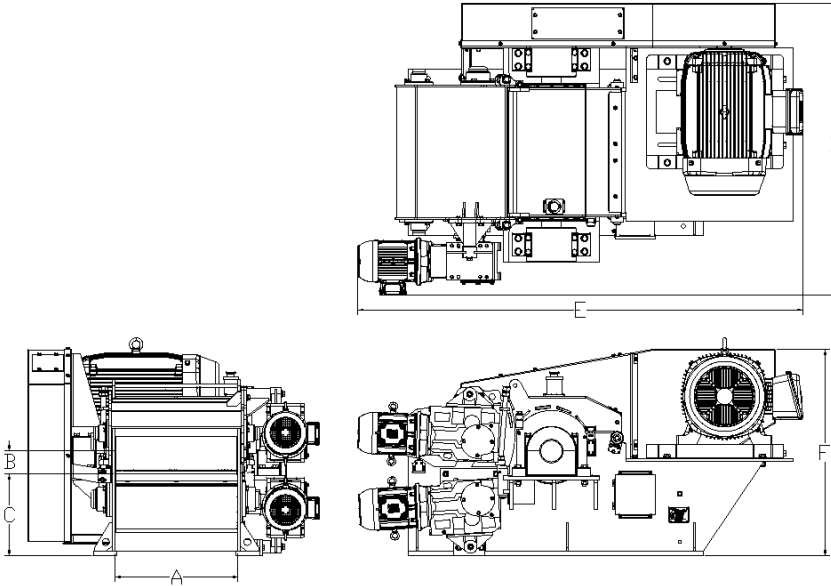

	42"
	15" ROTOR
A	25.6
B	1.0" - 5.0"
C	17.8
D	61.1
E	92.1
F	43.5

*Specifications, appearances, and dimensions are subject to change without notice.

Optional Features

- Multiple Cutter Rows
- Electronic Soft Start
- Standard Round Hole Screens 1/2" thru 4" Size
- Water Cooled Rotor
- Stainless Steel Machine Components

Optional Auxiliary Components

- Shaker Table Infeed System
- Discharge Blower Evacuation System
- Belt Outfeed Conveyor Systems
- Auger Outfeed Systems
- Integrated Downstream Granulators for
- Final Sizing of Re grind Material
- Discharge Blower Evacuation System
- Complete System Control Integration
- Magnetic Separators & Detector Systems
- Material Fines Separation & Classification Systems