



F 515
F 615
F1015
F1315





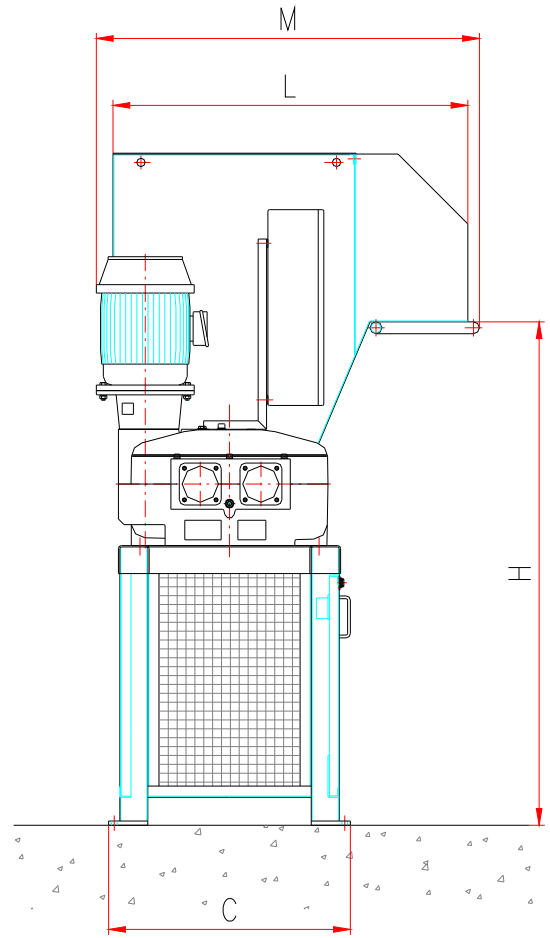
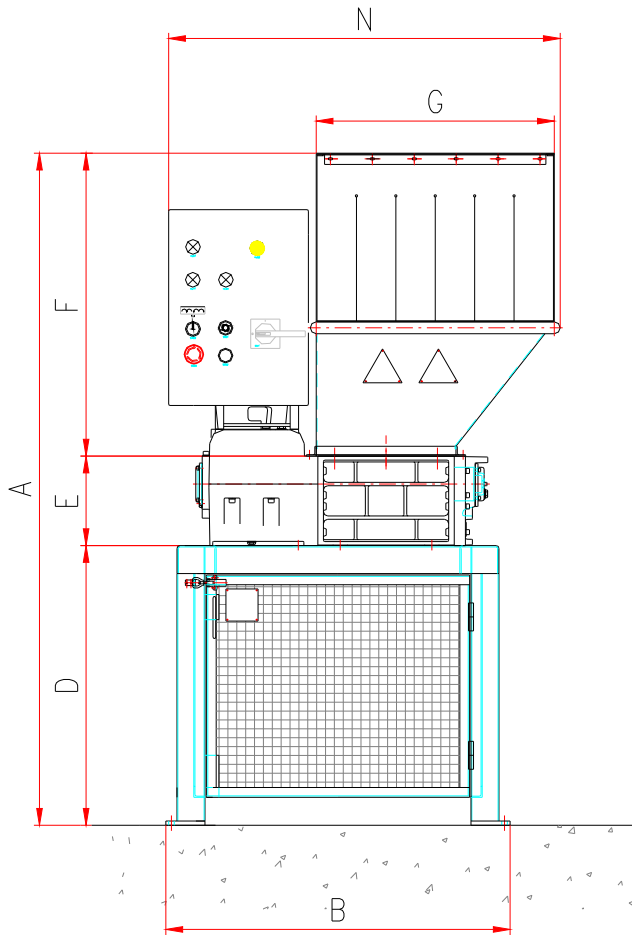

Dati tecnici Technical data	F515	F615	F1015	F1315
Camera di lavoro (mm) Shredding chamber (mm)	488X620	578X620	1028X620	1268X620
Lame da 15 mm (n.) 15 mm blades (no.)	32	38	68	84
Lame da 30 mm (n.) 30 mm blades (no.)	16	19	34	42
Potenza (kW) Power (kW)	11	11	11	11
Tensione (V) Voltage (V)	220/400/460	220/400/460	220/400/460	220/400/460
Peso (kg) Weight (kg)	1350	1430	1800	2100

Per pezzature piccole e uniformi prevista versione con sistema a controlame "CL"
For small and uniform material shred size available version with "CL" Counter Blades System

Dati Tecnici/Technical Data



Esempi di materiali trattati / Some applications:

- 
 Pneumatici auto
Car tyres
40 ÷ 100 pcs/h
- 
 Lattoname
Metal
300 ÷ 600 Kg/h
- 
 Rifiuti da catering
Waste from catering
300 ÷ 600 Kg/h
- 
 Plastica
Plastics
200 ÷ 500 Kg/h
- 
 Documenti
Confidential documents
250 ÷ 350 Kg/h
- 
 Scarti industriali
Industrial scraps
200 ÷ 400 Kg/h

	F515	F615	F1015	F1315
A	2400	2400	2400	2400
B	1230	1230	1680	1920
C	865	865	865	865
D	1000	1000	1000	1000
E	320	320	320	320
F	1080	1080	1080	1080
G	850	850	1040	1285
H	1800	1800	1800	1800
L	1270	1270	1270	1270
M	1370	1370	1370	1370
N	1400	1400	1590	1830

CAT1007 Rev. A 04/15

SatrindTech S.r.l.

Via Monfalcone, 122 - 20010 Arluno (MI) - Italy

Tel. (+39) 02 90376683

Fax (+39) 02 90376721

info@satrindtech.com

www.satrindtech.com

