

NP80-II is flexible, adaptable to various materials and customer needs. Front-loaded, safe and easy to operate, silent-running, fast and efficient.

- ▶ Compacts paper and cardboard, plastic foil, crates etc, to a bale
- ▶ High compaction pressure and generous feed opening on a minimum of floor space
- ▶ Convenient operating height
- ▶ Total height below 2 m
- ▶ Very reliable, proven long-lasting performance, even outdoors

NP80 with the unique self-lubricating worm drive (no hydraulic oil) is appreciated all over the world - a result of more than 50 years of designing and manufacturing balers.

New technique makes the NP80-II even more efficient and simplifies operation:

Plug'n Press - the modern control system surveys the starting up and during operation

Autostart - the baler starts compacting automatically when the feed door is closed.

Stay'n hold - the press ram stops in compaction mode (with full press power), giving even more compact bales. Suitable for materials that raise up after compaction. During the 'Stay'n hold' no electricity is needed!

Both "Autostart" and "Stay'n hold" can be switched on/off.



By a pallet truck the NP80-II is easily located/relocated where it's needed the most. Overall, the NP80-II is a flexible and sustainable solution for economy as well as environment!

Distinctness



The control system can easily provide additional features for customized solutions.

Easy location



All work is done from the front. The bale strapping rolls are easy to replace, each roll separately.

Efficiency



The feed door can be opened 90° or all the way down 180°. Close the feed door for automatic compaction.

Volume reduction



Built-in ejection of bale. The bale suits on a EUR-pallet. A volume reduction of up to 95%!

NP80-II baler

- the best seller -

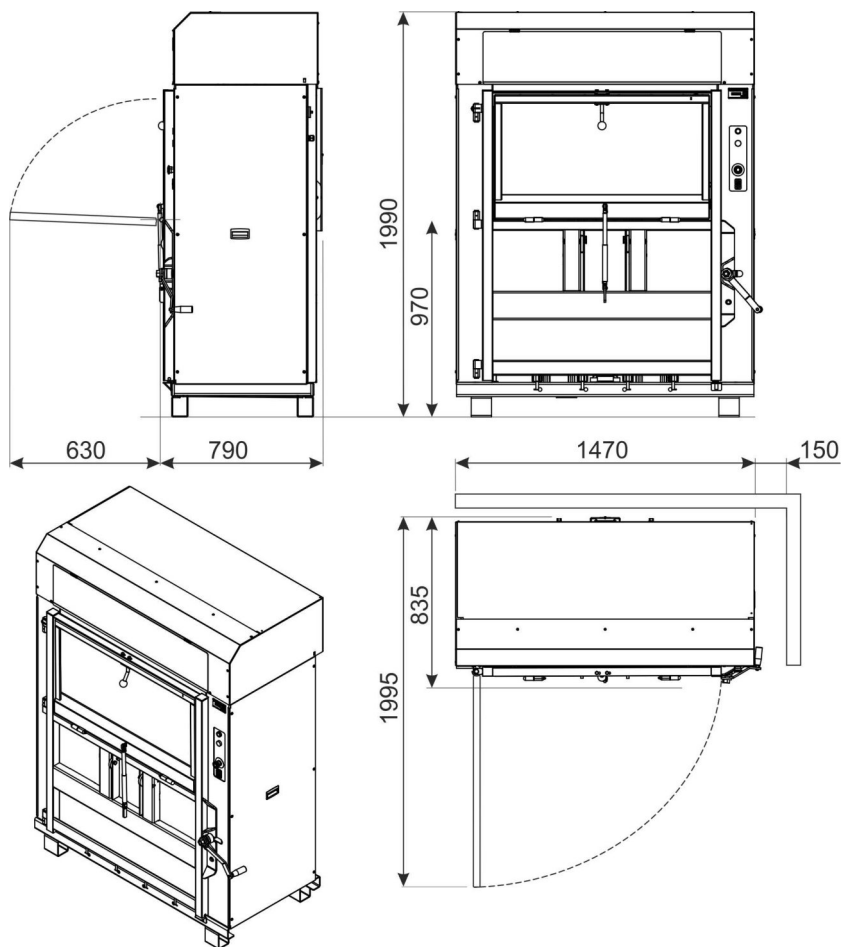

The door of NP80-II can be fully opened (180°), so that the bale can be easily removed even in small spaces.



Since the mid-sixties more than 15,000 balers have been delivered all over the world.



Components from global world class suppliers ensure quality and availability.



Our continuous development in close co-operation with users world wide gives us a unique knowledge of compacting and recycling.

The result is an outstanding range of products representing good design with excellent performance.

All compactors from NVA carry the CE-mark.



Model	Pressure kN	Weight kg	Feed opening mm	Bale size mm			Bale weight kg	dB(A)
				Length	Width	Height		
NP80-II	180	740	1100 x 550	1100	650	700-800	160 - 210	62

Voltage: 3-phase 400 V 50 Hz in standard version. Other voltages available.
 NP80 is the best-seller in our range of balers - please contact us for more information of other products.
 We reserve the right to introduce technical alterations.

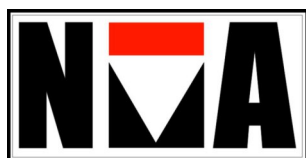

NÄTTRABY VERKTYGS AB
 Angelskogsvägen 8, SE - 372 38 RONNEBY
 Tel. +46 457 19220
 www.nva.se - info@nva.se
 SWEDEN

