

LP 50 EHF Prepress Technology Baler



The baler

- Robust design with highest possible reliability.
- User and service friendly.
- Optimized bale size and big feed opening.
- Friction channel pressure control within a fixed frame
- The upper friction flap pressure controlled by means of a hydraulic cylinder, the friction flaps controlled manually by means of adjusting screws
- The friction flap pressure level adjustable from the control panel.
- Main press top and bottom with cam design for better sealing
- Main press rolling on four heavy-duty wheels guided on wear rails mounted in the press bottom
- Heavy duty bearings for the pre-press shaft, bearings with exchangeable shaft sleeves
- Sturdy wear blocks on side and top
- Bottom plate made of 16 mm long-life resistant steel
- Exchangeable wear rails in the bottom
- Support legs (optional) to eliminate the need of a needle pit
- Detection system of the pre-press position during operation to secure a safe interlock of inspection hatches and protection covers.

The pre-press technology

- Ensures that the material always produces a constant counter pressure in the main press chamber.
- Up to 50 % lower energy consumption compared to a baler without prepress.
- No knives on the main ram, no risk for material jamming between knives and press plate.
- All of the press force utilized for material compaction.
- Increased volume capacity of the machine; the number of pre-pressing operations may be determined depending on the material to be baled.
- Guarantees an even density throughout the bale = square bales.
- Makes it possible to bale big size material without using a shredder.
- Makes it possible to bale most recyclables to dense, square bales.
- Low service and maintenance costs.

The hydraulics

- Main drive motor 22 kW (EH1), 37kW (EH2) and 45 kW (EH3) with a double hydraulic pump system
- Oil level control system
- Oil temperature transmitter - oil temperature indicated on control panel screen
- Oil cooler
- Oil heater (optional)
- All hydraulic components from well reputed, established suppliers.

The strapping

- Strapping system with fully automatic tying unit for 5 polypropylene strings.
- Automatic knotter and string cutting device.
- The tensile strength of the polypropylene string is comparable to steel wire.

The control system

- PREMI 50 HMI Interface system with a fixed Internet connection for operation control and monitoring, presetting of 20 baling programmes.
- Easy operation with a 12" colour Touch Screen
- Quick couplings for quick and safe installation
- A photocell system for baler and conveyor control

LP 50 EHF Dimensions

Presona®

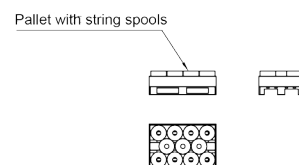
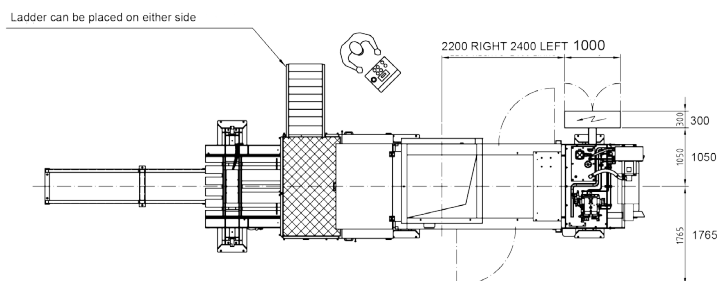
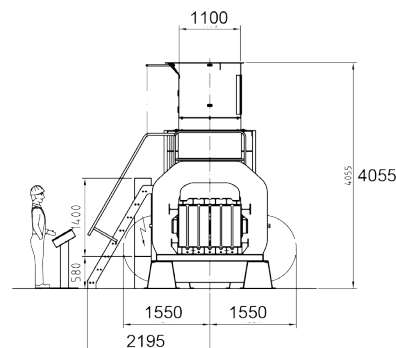
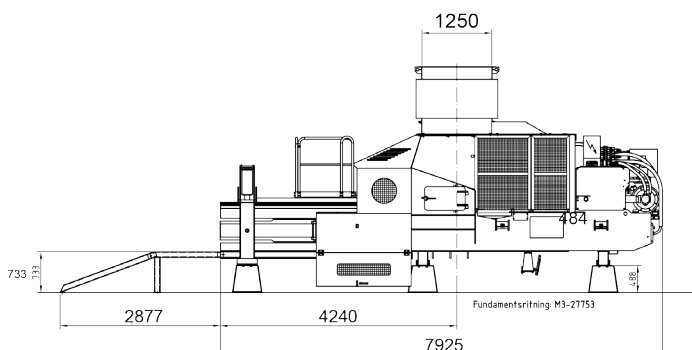

Technical Data		LP 50 EHF1	LP 50 EHF2	LP 50 EHF3
Theoretical volume capacity	m ³ /h	530	640	830
Max volume capacity	m ³ /h	260	340	430
Weight capacity*	t/h	6 - 14	8 - 22	10 - 27
Feed opening L x W	mm	1250 x 1100	1250 x 1100	1250 x 1100
Bale size H x W (Length variable)	mm	720 x 1100	720 x 1100	720 x 1100
Bale weight	kg/m ³	400 - 550	400 - 550	400 - 550
No. of vertical strapping strings		5	5	5
Press force pre-press	t	25	25	25
Press force main press	t	50	50	50
Specific pressure	N/cm ²	63	63	63
Max oil pressure	Bar	250	250	250
Oil tank capacity	Litres	600	600	1000
Electric motor	kW	22	37	45
Oil cooler	kW	1,0 + 1,5	1,0 + 1,5	1,0 + 1,5
Machine weight	t	~ 16	~ 16	~ 16

* At a material pre-bale density of 30 - 100 Kg/m³

Performance rates and bale densities are subject to moisture, material pre-bale densities, feed rate and other variables when baling.

As part of our continuous product development, specifications are subject to change without notice.