

WastePac 550 HD Baler



BALER DIMENSIONS

Height	3.500 m
Width	2.115 m
Depth	1.200 m
Weight	1935 kg
Transportation Height	2.500 m
Power Supply	400V 3 Phase
Motor	11kW 32A
Pressing Force	Up to 50T
Noise Level	75 dB
Cycle Time	50 Seconds

BALE DIMENSIONS

Height	1.200 m
Width	1.500 m
Depth	0.769 m
Weight	Up to 610kg

LOADING APERTURE SIZES

Height	0.880 m
Width	1.500 m

550 HD BALER FEATURES

- Can bale a variety of waste products including plastics, PET bottles, textiles, car bumpers, tyres, and heavy duty materials
- Extended cylinders produce a more compact bale
- Retainer claws to prevent spring back of material
- Fully automated bale ejector

OPTIONAL EXTRAS

- Low noise pump 64 db
- Available with 220-240 volts power supply



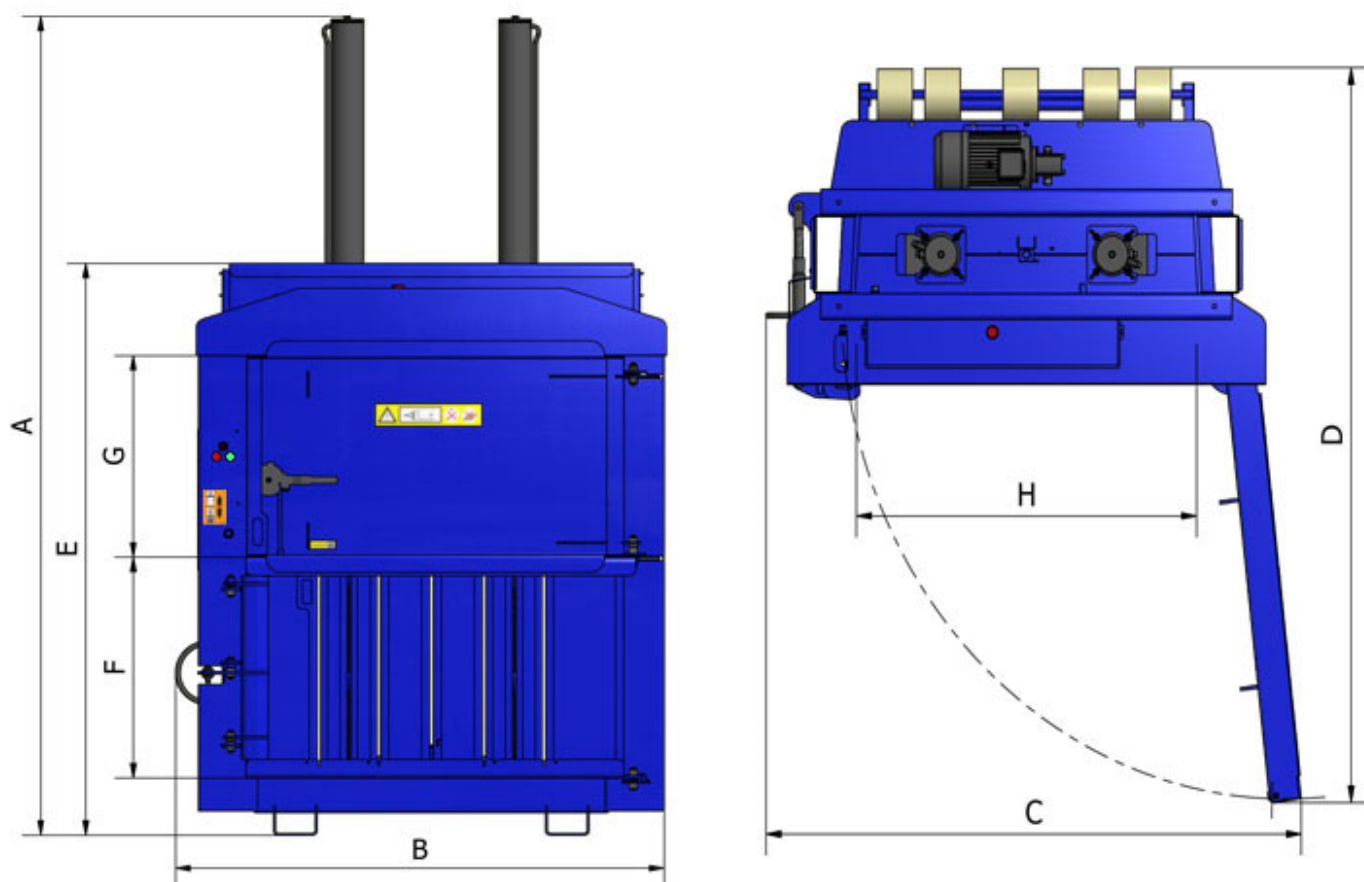

A 3.500 m

B 2.115 m

C 2.266 m

D 2.784 m

E 2.500 m

F 0.961 m

G 0.881 m

H 1.484 m

