

K 8/30
K10/30
K13/30

Dati tecnici	K 8/30	K 10/30	K 13/30
Camera di lavoro (mm) Shredding chamber (mm)	758x850	1008x850	1258x850
Lame da 30 mm (n.) 30 mm blades (no.)	25	33	41
Lame da 50 mm (n.) 50 mm blades (no.)	15	20	25
Potenza (kW) Power (kW)	22	22	22
Tensione (V) Voltage (V)	220/400/460	220/400/460	220/400/460
Peso (kg) Weight (kg)	3600	4000	4400

Per pezzature piccole e uniformi prevista versione con sistema a controlame "CL"
For small and uniform material shred size available version with "CL" Counter Blades System

Dati Tecnici/Technical Data

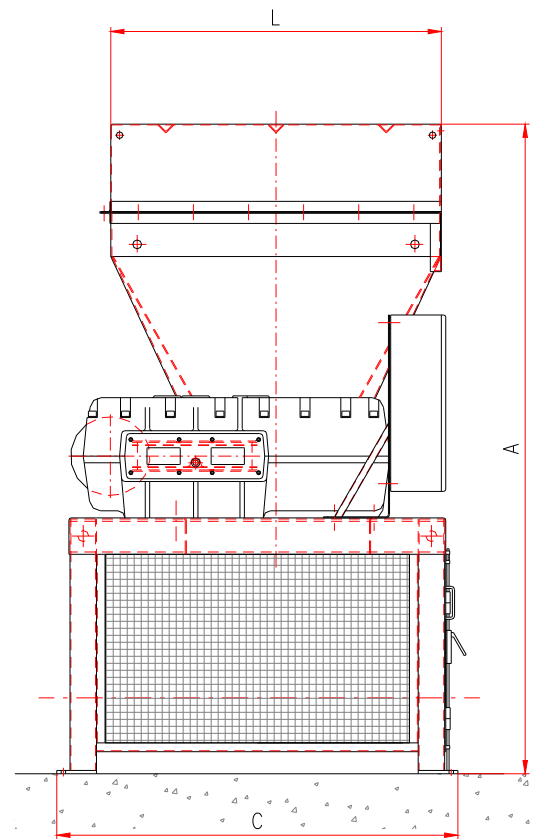
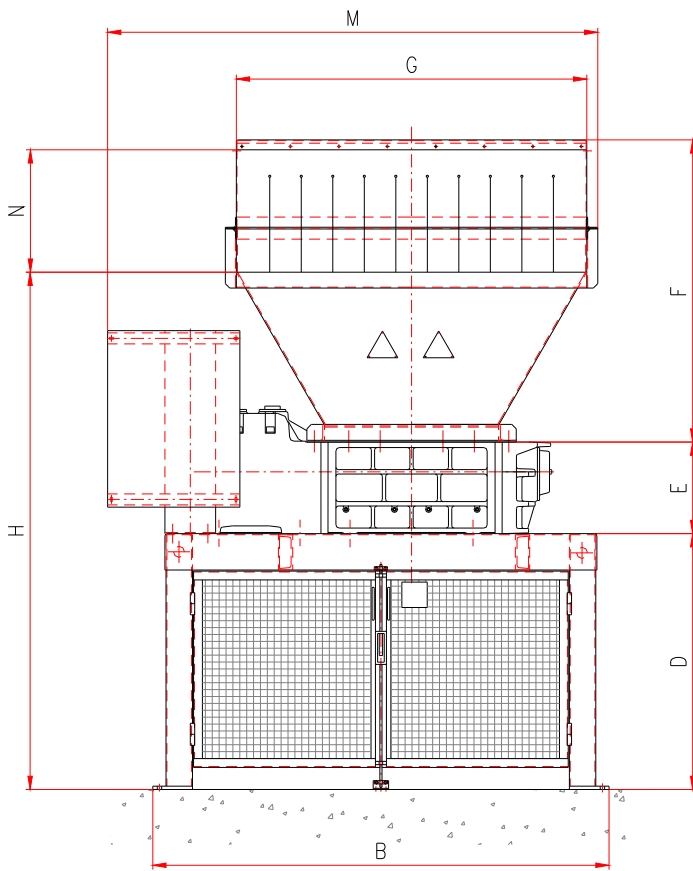

Esempi di materiali trattati / Some applications:

Fusti di plastica
Plastics drums



600 ÷ 1500 Kg/h

Rifiuti industriali
Industrial scraps



600 ÷ 2000 Kg/h

Barattolame (25-50 l)
Tins (25-50 l)



600 ÷ 1200 Kg/h

	K8/30	K10/30	K13/30
A	2945	2945	2945
B	2070	2170	2420
C	1820	1820	1820
D	1160	1160	1160
E	415	415	415
F	1370	1370	1370
G	1590	1840	2090
H	2345	2345	2345
L	1500	1500	1500
M	2225	2450	2700
N	555	555	555

CAT1009 Rev. A 04/15

SatrindTech S.r.l.

Via Monfalcone, 122 - 20010 Arluno (MI) - Italy

Tel. (+39) 02 90376683

Fax (+39) 02 90376721

info@satrindtech.com

www.satrindtech.com

